

FINAL

# ENVIRONMENTAL RISK ASSESSMENT FOR THE CAMECO PORT HOPE CONVERSION FACILITY

March 2016



[Redacted]

[Redacted]

[Redacted]

[Redacted]

[Redacted]

[Redacted]

[Redacted]

[Redacted]

# FINAL – ENVIRONMENTAL RISK ASSESSMENT FOR THE CAMECO PORT HOPE CONVERSION FACILITY

Prepared for:  
Cameco Port Hope Conversion Facility

Prepared by:  
Arcadis Canada Inc.  
121 Granton Drive, Suite 12  
Richmond Hill, ON L4B 3N4

Tel 905.764.9389  
Fax 905.764.9386

Our Ref.:  
351146

Date:  
March 2016

*This document is intended only for the use of the individual or entity for which it was prepared and may contain information that is privileged, confidential and exempt from disclosure under applicable law. Any dissemination, distribution or copying of this document is strictly prohibited.*

## CONTENTS

1	INTRODUCTION .....	1-1
1.1	Background.....	1-1
1.2	Present Objective and Scope .....	1-7
1.3	Report Organization .....	1-9
2	SITE DESCRIPTION .....	2-1
2.1	Site History .....	2-1
2.2	Natural and Physical Environment .....	2-2
2.2.1	Geology & Hydrogeology .....	2-2
2.2.2	Terrestrial and Aquatic Environments.....	2-3
2.2.3	Meteorological Statistics and Climate Setting.....	2-4
2.3	Available Environmental Monitoring Data .....	2-9
2.3.1	Groundwater Quality Data .....	2-9
2.3.2	Soil Quality Data .....	2-9
2.3.3	Surface Water Quality Data .....	2-10
2.3.4	Sediment Quality Data .....	2-10
2.3.5	Air Quality and Noise Data.....	2-11
2.3.6	Stormwater Quality Data.....	2-11
2.3.7	Radionuclide & Gamma Measurement Data .....	2-12
2.3.8	Uncertainties in Site Description .....	2-14
3	MODELLING .....	3-1
3.1	Modelling Air Releases.....	3-1
3.1.1	Sources .....	3-1
3.1.2	Receptors.....	3-1
3.1.3	Model Results .....	3-1
3.1.4	Calculation of Deposition Velocity.....	3-5
3.1.5	Comparison: Model vs. Monitoring Data.....	3-5
3.2	Modelling Off-Site Soil Concentrations.....	3-6
3.3	Modelling Groundwater & Stormwater Loadings to Surface Water.....	3-10
3.3.1	Approach.....	3-10

3.3.1.1	Groundwater Discharges.....	3-10
3.3.1.2	Stormwater Discharges.....	3-14
3.3.2	Model Setup & Conditions.....	3-17
3.3.3	Model Station Locations.....	3-17
3.3.4	Model Results and General Conclusions.....	3-19
3.4	Gamma Modelling.....	3-21
3.4.1	Potential Neutron Dose:.....	3-24
4	PRELIMINARY SCREENING – SELECTION OF CONTAMINANTS OF POTENTIAL CONCERN..	4-1
4.1	Groundwater – Preliminary Screening.....	4-2
4.2	Soil – Preliminary Screening.....	4-9
4.3	Surface Water – Preliminary Screening.....	4-16
4.4	Summary – Preliminary Screening.....	4-23
4.5	Additional Media: Air, Stormwater and Sediment.....	4-27
4.6	Gamma.....	4-37
4.7	Uncertainties in Preliminary COPC Screening.....	4-40
5	HUMAN HEALTH RISK ASSESSMENT.....	5-1
5.1	Problem Formulation.....	5-1
5.1.1	Receptor Selection & Characterization.....	5-1
5.1.2	Human Health COPCs and Stressors – Secondary Screening.....	5-9
5.1.2.1	COPCs for Groundwater – Human Health.....	5-9
5.1.2.2	COPCs for Soil – Human Health.....	5-14
5.1.2.3	Overall List of COPCs for HHRA.....	5-19
5.1.3	HHRA Exposure Pathways.....	5-21
5.1.3.1	Soil Exposure Pathways.....	5-21
5.1.3.2	Groundwater Exposure Pathways.....	5-22
5.1.3.3	Air Exposure Pathways.....	5-22
5.1.3.4	Surface Water Exposure Pathways.....	5-22
5.1.3.5	Contaminated Food Exposure Pathways.....	5-23
5.1.3.6	Sediment Exposure Pathways.....	5-23
5.1.3.7	Gamma Radiation Exposure Pathway.....	5-23
5.1.3.8	External Radiation Exposure.....	5-23
5.1.3.9	Summary of Inactive/Non-Applicable Exposure Pathways.....	5-24
5.1.3.10	Summary of Active HHRA Exposure Pathways.....	5-25

5.1.4	HHRA Conceptual Site Model (CSM) .....	5-28
5.1.5	Tiered Approach to HHRA .....	5-28
5.2	Exposure Assessment .....	5-33
5.2.1	Exposure Locations .....	5-33
5.2.2	Exposure Factors, Durations & Frequencies .....	5-35
5.2.3	Exposure Point Concentrations .....	5-40
5.2.3.1	Soil, Groundwater and Surface Water .....	5-40
5.2.3.2	Direct Gamma .....	5-46
5.2.4	Radiological Dose Calculation Methods .....	5-46
5.2.4.1	Internal Dose from Inhalation .....	5-46
5.2.4.2	Internal Dose from Incidental Ingestion of Groundwater .....	5-46
5.2.4.3	Internal Dose from Incidental Ingestion of soil .....	5-47
5.2.4.4	Internal Dose from Ingestion of Contaminated Foods .....	5-47
5.2.4.5	External Dose from Immersion in Surface Water .....	5-48
5.2.4.6	External Dose from Ground Deposits .....	5-48
5.2.5	Gamma External Dose Calculation Methods .....	5-49
5.2.6	Dose Coefficients .....	5-50
5.2.7	Non-Radiological Dose Calculation Methods .....	5-52
5.2.7.1	Incidental Ingestion of Soil .....	5-52
5.2.7.2	Ingestion of Contaminated Food .....	5-52
5.2.7.3	Incidental Ingestion of Surface Water While Swimming .....	5-53
5.2.7.4	Soil Dermal Uptake .....	5-54
5.2.7.5	Surface Water Dermal Uptake .....	5-56
5.2.7.6	Inhalation .....	5-60
5.2.7.7	Inhalation of Vapours .....	5-61
5.2.8	Exposure Calculation Results .....	5-63
5.2.8.1	Non-Radiological Dose Estimates .....	5-63
5.2.8.2	Radiological (Radionuclide) Dose Estimates .....	5-63
5.2.8.3	Gamma Dose Estimates .....	5-65
5.3	Toxicity Assessment .....	5-67
5.3.1	Non-Radiological COPCs – Toxicological Reference Values .....	5-67
5.3.2	Radiological COPCs – Radiation Dose Limits .....	5-78
5.4	Risk Characterization .....	5-78

5.4.1	Radiological Risk Characterization .....	5-78
5.4.2	Non-Radiological Risk Characterization .....	5-78
5.4.2.1	Addition Across Exposure Routes .....	5-80
5.4.3	Risk Estimation .....	5-81
5.4.3.1	Radiological Risk .....	5-81
5.4.3.2	Non-Radiological Hazard and Risk .....	5-82
5.4.4	Discussion.....	5-104
5.4.4.1	Radiological .....	5-104
5.4.4.2	Non-Radiological .....	5-104
5.5	Uncertainties in the HHRA.....	5-115
6	ECOLOGICAL RISK ASSESSMENT .....	6-1
6.1	Problem Formulation .....	6-1
6.1.1	Receptor Selection and Characterization .....	6-1
6.1.1.1	Ecological Receptor Selection.....	6-1
6.1.1.2	Species at Risk.....	6-3
6.1.1.3	Receptor Characterization.....	6-8
6.1.2	Assessment and Measurement Endpoints .....	6-8
6.1.3	Ecological COPCs and Stressors – Secondary Screening.....	6-9
6.1.3.1	COPCs for Groundwater – Ecological Health .....	6-9
6.1.3.2	COPCs for Soil - Ecological Health .....	6-12
6.1.3.3	Overall List of COPCs for Ecological Risk Assessment.....	6-16
6.1.4	EcoRA Exposure Pathways .....	6-18
6.1.5	EcoRA Conceptual Site Model (CSM) .....	6-21
6.1.6	Tier Approach to EcoRA .....	6-21
6.2	Exposure Assessment.....	6-23
6.2.1	Exposure Points.....	6-23
6.2.2	Exposure Factors for Receptors .....	6-27
6.2.3	Exposure Durations and Averaging .....	6-30
6.2.4	Exposure Point Concentrations .....	6-31
6.2.5	Non-Radiological Dose Calculation Methods .....	6-49
6.2.5.1	Hypothetical Groundwater Invertebrate Method.....	6-49
6.2.6	Radiological Dose Calculation Methods .....	6-50
6.2.6.1	Aquatic Biota – Internal & External Radiation Dose.....	6-50

6.2.6.2	Terrestrial Biota – Internal & External Radiation Dose.....	6-51
6.2.6.3	Radiation Weighting Factors .....	6-52
6.2.6.4	Dose Coefficients .....	6-52
6.2.7	Transfer Factors.....	6-67
6.2.8	External Gamma .....	6-72
6.3	Effects Assessment .....	6-72
6.3.1	Non-Radiological Benchmark Values .....	6-72
6.3.1.1	Terrestrial Invertebrates and Vegetation .....	6-73
6.3.1.2	Terrestrial Mammals and Terrestrial Birds .....	6-76
6.3.1.3	Aquatic Birds.....	6-83
6.3.1.4	Aquatic Biota (Fish, Vegetation, and Invertebrates).....	6-86
6.3.2	Radiological Dose Benchmarks .....	6-91
6.4	Risk Characterization .....	6-92
6.4.1	Risk Results – Radiological .....	6-92
6.4.1.1	Terrestrial (Radiological) .....	6-92
6.4.1.2	Aquatic (Radiological).....	6-97
6.4.2	Risk Results – Radiological (including Radon Rn-222) .....	6-99
6.4.3	Updated Dose Calculations .....	6-100
6.4.4	Discussion of Updated Dose Results for Biota .....	6-105
6.4.5	Risk Results – Non-Radiological.....	6-106
6.4.5.1	Terrestrial (Non-Radiological).....	6-106
6.4.5.2	Aquatic (Non-Radiological).....	6-117
6.4.6	Summary and Discussion of Results .....	6-120
6.4.6.1	Radiological .....	6-120
6.4.6.2	Non-Radiological .....	6-120
6.5	Uncertainties in the EcoRA.....	6-127
7	ASSESSMENT OF PHYSICAL STRESSORS.....	7-1
7.1	Fish Entrainment Assessment.....	7-1
7.1.1	Introduction & Overview .....	7-1
7.1.2	Objectives .....	7-1
7.1.3	Methodology.....	7-2
7.1.3.1	Sampling.....	7-2
7.1.3.2	Overall Estimates .....	7-2

7.1.3.3	Incidental Fish Collections.....	7-3
7.1.4	Results .....	7-3
7.1.5	Conclusions.....	7-7
7.2	Fish Thermal Effects Assessments .....	7-7
7.2.1	Introduction & Overview of Studies.....	7-7
7.2.2	Thermal Plume Effects Study (SENES 2012a).....	7-8
7.2.2.1	Objectives .....	7-8
7.2.2.2	Methodology .....	7-8
7.2.2.3	Results.....	7-9
7.2.2.4	Objectives .....	7-10
7.2.3	Thermal Effects Risk Assessment (SENES 2013c).....	7-10
7.2.3.1	Methodology .....	7-10
7.2.3.2	Results.....	7-11
7.2.4	Thermal Risk Assessment Follow Up (SENES 2014b) .....	7-12
7.2.4.1	Objectives .....	7-12
7.2.4.2	Methodology .....	7-13
7.2.4.3	Results.....	7-14
7.2.5	Conclusions.....	7-14
7.3	Acoustic Assessment .....	7-16
7.3.1	Introduction & Overview .....	7-16
7.3.2	Objectives .....	7-16
7.3.3	Methodology.....	7-16
7.3.4	Results .....	7-17
7.3.5	Conclusions.....	7-19
7.4	Assessment of Acute Effects from Stormwater Pulses .....	7-19
7.5	Uncertainties in the Assessment of Physical Stressors .....	7-24
8	CONCLUSIONS AND RECOMMENDATIONS.....	8-1
8.1	Summary of ERA Results.....	8-1
8.2	Recommendations.....	8-2
9	QUALITY ASSURANCE AND QUALITY CONTROL.....	9-1
9.1	Monitoring Program .....	9-2
10	REFERENCES.....	10-1



## TABLES

Table 2.1 Availability of Measured Radionuclide Data.....	2-13
Table 3.1 Model Predicted Average Annual Uranium Concentrations ( $\mu\text{g}/\text{m}^3$ ) at the Risk Receptors .....	3-2
Table 3.2 Calculated Deposition Velocities .....	3-5
Table 3.3 Comparison of Modelled vs. Monitored Uranium Concentrations.....	3-6
Table 3.4 Comparison of Modelled vs. Monitored Uranium Deposition Rates .....	3-6
Table 3.5 Off-Site Soil Modelling and Results.....	3-8
Table 3.6 Groundwater Discharges.....	3-11
Table 3.7 Stormwater Discharges and Concentrations – Averaged over the Year .....	3-14
Table 3.8 Model Estimate Locations: Grid Coordinates.....	3-17
Table 3.9 Gamma Modelling Results – Effective & Annual Dose Rates.....	3-21
Table 4.1 Groundwater: Preliminary Screening .....	4-3
Table 4.2 Soil: Preliminary Screening .....	4-10
Table 4.3 Surface Water: Preliminary Screening .....	4-17
Table 4.4 Summary of Preliminary Screening COPCs .....	4-23
Table 4.5 Air Quality Data and Comparison to Guidelines.....	4-28
Table 4.6 Stormwater Data.....	4-30
Table 4.7 Maximum Measured Sediment Concentrations .....	4-35
Table 4.8 2014 Measured Fenceline Gamma Data .....	4-38
Table 5.1 HHRA: Identification of Human Receptors.....	5-2
Table 5.2 Groundwater: Human Health Secondary Screening of COPCs.....	5-10
Table 5.3 Soil: Human Health Secondary Screening of COPCs.....	5-16
Table 5.4 Overall List of COPCs for HHRA.....	5-19
Table 5.5 HHRA Exposure Pathways Summary – Off-Site Public Receptors .....	5-26
Table 5.6 HHRA – Problem Formulation Checklist .....	5-31
Table 5.7 Human Receptor Exposure Locations and Environmental Media .....	5-33
Table 5.8 HHRA Exposure Factors & Durations – Off-Site Public Receptors .....	5-36
Table 5.9 HHRA – Soil Concentrations – Off-Site Residential Yard Soil Concentrations (PHCF and Dorset Street East Sites).....	5-41
Table 5.10 HHRA – Harbour Surface Water Concentrations for Off-Site Public Receptors.....	5-42
Table 5.11 HHRA – Beach Surface Water Concentrations for Off-Site Public Receptors.....	5-44

Table 5.12 HHRA – Dose Coefficients .....	5-51
Table 5.13 HHRA – Dermal Absorption Factors (Soil).....	5-55
Table 5.14 HHRA – Dermal Permeability Coefficients.....	5-59
Table 5.15 HHRA – Tier 1 Radionuclide Dose Estimates (in mSv/y).....	5-64
Table 5.16 Tier 1 Gamma Dose Rates for Human Receptors .....	5-66
Table 5.17 HHRA – TRVs .....	5-69
Table 5.18 HHRA – Radiological Benchmarks.....	5-78
Table 5.19 HHRA – Radiological Risk Results – Public Receptors (Tier 1) .....	5-82
Table 5.20 HHRA – HQ & Risk – Resident Receptors (Surface Water, T1).....	5-84
Table 5.21 HHRA – HQ – Resident Receptors (Off-Site Soil, T1) .....	5-85
Table 5.22 HHRA – HQ – Park User Receptors (Off-Site Soil, T1) .....	5-87
Table 5.23 HHRA – HQ – Resident Receptors (Indoor & Outdoor Air, U only, T1) .....	5-90
Table 5.24 HHRA – HQ – Park User Receptors (Outdoor Air, U only, T1).....	5-90
Table 5.25 HHRA – HQ & Risk – Fisherman Receptors (Surface Water, T1).....	5-91
Table 5.26 HHRA – HQ – Fisherman Receptors (Air; U only, T1).....	5-91
Table 5.27 HHRA – HQ & Risk – Yacht/Boat Receptors (Surface Water, T1) .....	5-92
Table 5.28 HHRA – HQ – Off-Site Yacht/Boat Receptors (Air; U only, T1) .....	5-92
Table 5.29 HHRA – HQ – Off-Site Fenceline Walker Receptors (Air; U only, T1).....	5-92
Table 5.30 HHRA – HQ – Off-Site Commercial Worker Receptors (Indoor & Outdoor Air; U only, T1) ..	5-92
Table 5.31 HHRA – HQ & Risk – Resident Receptors (Surface Water, T2a).....	5-93
Table 5.32 HHRA – HQ & Risk – Resident Receptors (Off-Site Soil, T2a).....	5-94
Table 5.33 HHRA – HQ & Risk – Park User Receptors (Off-Site Soil, T2a).....	5-95
Table 5.34 HHRA – HQ & Risk – Fisherman Receptor (Surface Water, T2a).....	5-96
Table 5.35 HHRA – HQ & Risk – Resident Receptor (Surface Water, T2b).....	5-96
Table 5.36 HHRA – HQ & Risk – Hayward St. Resident Receptor (Off-Site Soil, T2b).....	5-97
Table 5.37 HHRA – HQ & Risk – Madison St. Resident Receptor (Off-Site Soil, T2b) .....	5-98
Table 5.38 HHRA – HQ & Risk – Dorset St. Resident Receptor (Off-Site Soil, T2b) .....	5-99
Table 5.39 HHRA – HQ & Risk – Park User Receptor (Off-Site Soil, T2b).....	5-100
Table 5.40 HHRA – HQ & Risk – Fisherman Receptors (Surface Water, T2b) .....	5-101
Table 5.41 HHRA – HQ & Risk – Resident Receptor (Surface Water, T2c).....	5-102
Table 5.42 HHRA – HQ – Hayward St. Resident Receptor (Off-Site Soil, T2c; U only) .....	5-103
Table 5.43 HHRA – HQ – Madison St. Resident Receptor (Off-Site Soil, T2c; U only).....	5-103

Table 5.44 HHRA – HQ – Park User Receptor (Off-Site Soil, T2c; U only) .....	5-103
Table 5.45 HHRA – HQ & Risk – Fisherman Receptors (Surface Water, T2c) .....	5-104
Table 5.46 HHRA – Offsite Soil – Summary of Tier 1 HQ & Risk Exceedances .....	5-105
Table 5.47 HHRA – Offsite Soil – Summary of Tier 2a HQ & Risk Exceedances .....	5-107
Table 5.48 HHRA – Offsite Soil – Summary of Tier 2b HQ & Risk Exceedances .....	5-108
Table 5.49 HHRA – Summary of Uncertainties.....	5-117
Table 6.1 VEC/Ecological Receptor Selection .....	6-2
Table 6.2 Representation of Rare Species using Indicator Receptors .....	6-5
Table 6.3 Groundwater: Ecological Health Secondary Screening of COPCs.....	6-10
Table 6.4 Soil: Ecological Health Secondary Screening of COPCs.....	6-13
Table 6.5 Overall List of COPCs for EcoRA.....	6-17
Table 6.6 EcoRA Exposure Pathways Summary .....	6-19
Table 6.7 Ecological Receptors, Exposure Points and Environmental Media .....	6-24
Table 6.8 Overview of Exposure Factors for Ecological Receptors.....	6-28
Table 6.9 EcoRA – Home Range Fractions for Tier 2b.....	6-30
Table 6.10 EcoRA – Harbour Sediment Concentrations.....	6-32
Table 6.11 EcoRA – Lake Ontario Beach Sediment Concentrations (Estimated) .....	6-34
Table 6.12 EcoRA – Harbour Surface Water Concentrations.....	6-35
Table 6.13 EcoRA – Beach Surface Water Concentrations.....	6-37
Table 6.14 EcoRA – Soil Concentrations (Off-Site Residential Stations, PHCF & Dorset St East).....	6-39
Table 6.15 EcoRA – Soil Concentrations (PHCF Off-Site Grass Strip) .....	6-41
Table 6.16 EcoRA – Soil Concentrations (PHCF On-Site Grass Patches).....	6-43
Table 6.17 EcoRA – Soil Concentrations (PHCF On-Site Gravel Areas) .....	6-45
Table 6.18 EcoRA – Groundwater Concentrations (PHCF).....	6-47
Table 6.19 Comparison of Ecological Receptors to Reference Organisms (for DCs) .....	6-53
Table 6.20 EcoRA: Dose Coefficients – Terrestrial Biota, Internal .....	6-56
Table 6.21 EcoRA: Dose Coefficients – Terrestrial Biota, External .....	6-59
Table 6.22 EcoRA: Dose Coefficients – Aquatic Biota, Internal .....	6-62
Table 6.23 EcoRA: Dose Coefficients – Aquatic Biota, External .....	6-64
Table 6.24 EcoRA: Transfer Factors.....	6-68
Table 6.25 EcoRA TRVs: Terrestrial Plants & Earthworms (mg/kg).....	6-74
Table 6.26 EcoRA TRVs for Terrestrial Mammals (mg/kg/d).....	6-77

Table 6.27 EcoRA TRVs for Terrestrial Birds (mg/kg/d) .....	6-80
Table 6.28 EcoRA TRVs for Aquatic Birds (mg/kg/d) .....	6-84
Table 6.29 EcoRA TRVs for Aquatic Biota (mg/L) .....	6-87
Table 6.30 EcoRA Radiological Dose Benchmarks (mGy/d) .....	6-91
Table 6.31 EcoRA Radiological Dose (mGy/d) & SI Results - Terrestrial.....	6-92
Table 6.32 EcoRA - Radiological Dose (mGy/d) & SI Results (Aquatic) .....	6-97
Table 6.33 Original Dose Calculations for Benthos (excluding the contribution of Rn-222) .....	6-100
Table 6.34 Updated Dose Calculations for Benthos (Ra-226 dose now includes the contribution of Rn-222 (highlighted)).....	6-101
Table 6.35 Original Dose Calculations for Cotton Tail Rabbit (excluding the contribution of Rn-222) ..	6-101
Table 6.36 Updated Dose Calculations for Cotton Tail Rabbit (including the contribution of Rn-222) ..	6-102
Table 6.37 Original Dose Calculations for Meadow Vole (excluding the contribution of Rn-222) .....	6-102
Table 6.38 Updated Dose Calculations for Meadow Vole (including the contribution of Rn-222) .....	6-103
Table 6.39 Original Dose Calculations for Red Fox (excluding the contribution of Rn-222).....	6-103
Table 6.40 Updated Dose Calculations for Red Fox (including the contribution of Rn-222) .....	6-104
Table 6.41 Original Dose Calculations for Earthworm (excluding the contribution of Rn-222).....	6-104
Table 6.42 Updated Dose Calculations for Earthworm (including the contribution of Rn-222).....	6-105
Table 6.43 Percent Difference Between Total Dose Without and With Rn-222 Contribution .....	6-105
Table 6.44 EcoRA - Non-Radiological Risk Results – Terrestrial Receptors (Tier 1).....	6-107
Table 6.45 EcoRA – Non-Radiological Risk Results – Terrestrial Receptors (Tier 2a) .....	6-112
Table 6.46 EcoRA – Non-Radiological Risk Results – Terrestrial Receptors (Tier 2b) .....	6-114
Table 6.47 EcoRA – Non-Radiological Risk Results – Terrestrial Receptors (Tier 2c) .....	6-116
Table 6.48 EcoRA – Non-Radiological Risk Results – Aquatic Receptors (Tier 1) .....	6-118
Table 6.49 EcoRA – Non-Radiological Risk Results – Aquatic Receptors (Tier 2a) .....	6-119
Table 6.50 EcoRA – Non-Radiological Risk Results – Aquatic Receptors (Tier 2b) .....	6-119
Table 6.51 EcoRA – Non-Radiological Risk Results – Aquatic Receptors (Tier 2c).....	6-119
Table 6.52 EcoRA – Summary of Uncertainties.....	6-130
Table 7.1 Estimated Entrainment of Fish Larvae .....	7-4
Table 7.2 Estimated Entrainment of Fish Eggs.....	7-5
Table 7.3 Summary of Incidental Catch During Entrainment Sampling.....	7-6
Table 7.4 Acoustic Assessment Summary Table.....	7-18
Table 7.5 MNO: Acute TRVs for Aquatic Biota .....	7-22

Table 7.6 Physical Stressors – Summary of Uncertainties .....	7-25
Table 8.1 Summary of ERA Results.....	8-1
Table 9.1 Internal Peer Review of ERA.....	9-1

## FIGURES

Figure 1.1. Port Hope Conversion Facility Site (Aerial Photograph from 2007).....	1-2
Figure 1.2. Port Hope Conversion Facility Building Layout.....	1-3
Figure 1.3. UF <sub>6</sub> and UO <sub>2</sub> Process Plants .....	1-4
Figure 1.4. Aerial Photo of Dorset Street East (Warehouse) Site.....	1-8
Figure 2.1. Mean Daily Temperature (2011-2015).....	2-5
Figure 2.2. Total Monthly Precipitation (2011-2015).....	2-7
Figure 2.3. Wind Rose for Darlington 1996-2000 Meteorological Data Set.....	2-8
Figure 3.1. Annual Average Uranium Concentrations (µg/m <sup>3</sup> ).....	3-4
Figure 3.2. Cameco Off-Site Soil Sampling Locations.....	3-9
Figure 3.3. Groundwater Discharge Areas and Estimates (Golder 2015) .....	3-12
Figure 3.4. Groundwater Discharge Areas in Model.....	3-13
Figure 3.5. Stormwater Discharge Outlets (Golder 2011).....	3-15
Figure 3.6. Stormwater Discharge Outlets in Model .....	3-16
Figure 3.7. Model Estimate Locations (Harbour) .....	3-18
Figure 3.8. Model Estimate Locations (Lake Ontario).....	3-19
Figure 3.9. Selected Model Results: Simulated Uranium Concentrations in Surface Water for the Dynamic Stormwater Plus Averaged Groundwater Scenario. Surface. Legend Indicates Station Numbers.....	3-20
Figure 5.1. Human Health Receptor Locations .....	5-8
Figure 5.2. On-Site & Off-Site Sources of Contamination and Interactions.....	5-29
Figure 5.3. HHRA Conceptual Site Model – Off-Site Member of the Public Receptors.....	5-30
Figure 5.4. HHRA – Comparison of Fish Arsenic Levels (µg/g FW).....	5-111
Figure 5.5. HHRA – Estimated Child Total Arsenic Intakes vs Background (mg/kg-d).....	5-113
Figure 5.6. HHRA – Estimated Adult Total Arsenic Intakes vs Background (mg/kg-d).....	5-114
Figure 6.1. Potential Species at Risk in the Study Area NHIC (2009) Database Search Results .....	6-7
Figure 6.2. EcoRA Conceptual Site Model.....	6-22
Figure 6.3. EcoRA: Receptor Locations and Exposure Points.....	6-25
Figure 6.4. Example On-Site Gravel Areas .....	6-125
Figure 8.1. Off-Site Grass Strip Exceedances .....	8-3

[REDACTED]

[REDACTED]

[REDACTED]

[REDACTED]

[REDACTED]

[REDACTED]

[REDACTED]

# 1 INTRODUCTION

## 1.1 Background

The Cameco Corporation (Cameco) Port Hope Conversion Facility (PHCF) is situated on the north shore of Lake Ontario in the Municipality of Port Hope, Ontario. As seen in Figure 1.1, the facility is bounded on the west by Choate Road and the Municipality of Port Hope Waterworks, on the north by Hayward Street, and on the east by the Port Hope Harbour. The Centre Pier is bounded by Hayward Street to the north, the Port Hope Harbour to the west, Lake Ontario to the south and the Ganaraska River to the east. The PHCF occupies an area of 9.6 hectares and the Centre Pier 3.8 hectares

The Municipality of Port Hope Waterworks is located west of the PHCF. The main branch of the Ganaraska River empties into Lake Ontario east of the Harbour. The PHCF site is shown in Figure 1.2. The PHCF land has a long history of industrial use by multiple users starting in the mid to late 1800s.

The historic operations on the site were recognized to have resulted in surface and subsurface contamination on the Site and in the surrounding environment at the time Cameco was formed in 1988. A legal agreement exists between the federal government and the municipalities of Port Hope and Clarington for the clean-up and long term safe management of historic low-level radioactive waste. The Port Hope Area Initiative (PHAI) led by the Low Level Radioactive Waste Management Office (LLRWMO) and Cameco's Vision In Motion (VIM) project are being developed to address this historic contamination in the municipality (including Port Hope Harbour sediments) and the PHCF site, respectively.

The PHCF receives uranium trioxide ( $UO_3$ ) for conversion to either uranium hexafluoride ( $UF_6$ ) or uranium dioxide ( $UO_2$ ) at the buildings illustrated in Figure 1.3. Cameco routinely monitors releases of radioactive and non-radioactive chemicals to the environment (to air, water and waste) to ensure that they are within regulatory requirements. Cameco also monitors concentrations in the environment (air, soil, water and sediment).

In 2007, Cameco identified soil contamination during excavation for a new concrete in-ground containment structure in the uranium hexafluoride ( $UF_6$ ) conversion plant (Building 50). Cameco has undertaken several investigations and programs to characterize the extent of groundwater and soil impacts associated with the Building 50 event. Following the identification of sub-surface contamination in 2007, Cameco proceeded with additional activities in the areas of:

- Environmental Management/Remediation;
- Site Characterization; and
- Risk Assessment.



Final – Environmental Risk Assessment for the Cameco Port Hope Conversion Facility

Figure 1.1. Port Hope Conversion Facility Site (Aerial Photograph from 2007)



Figure 1.2. Port Hope Conversion Facility Building Layout

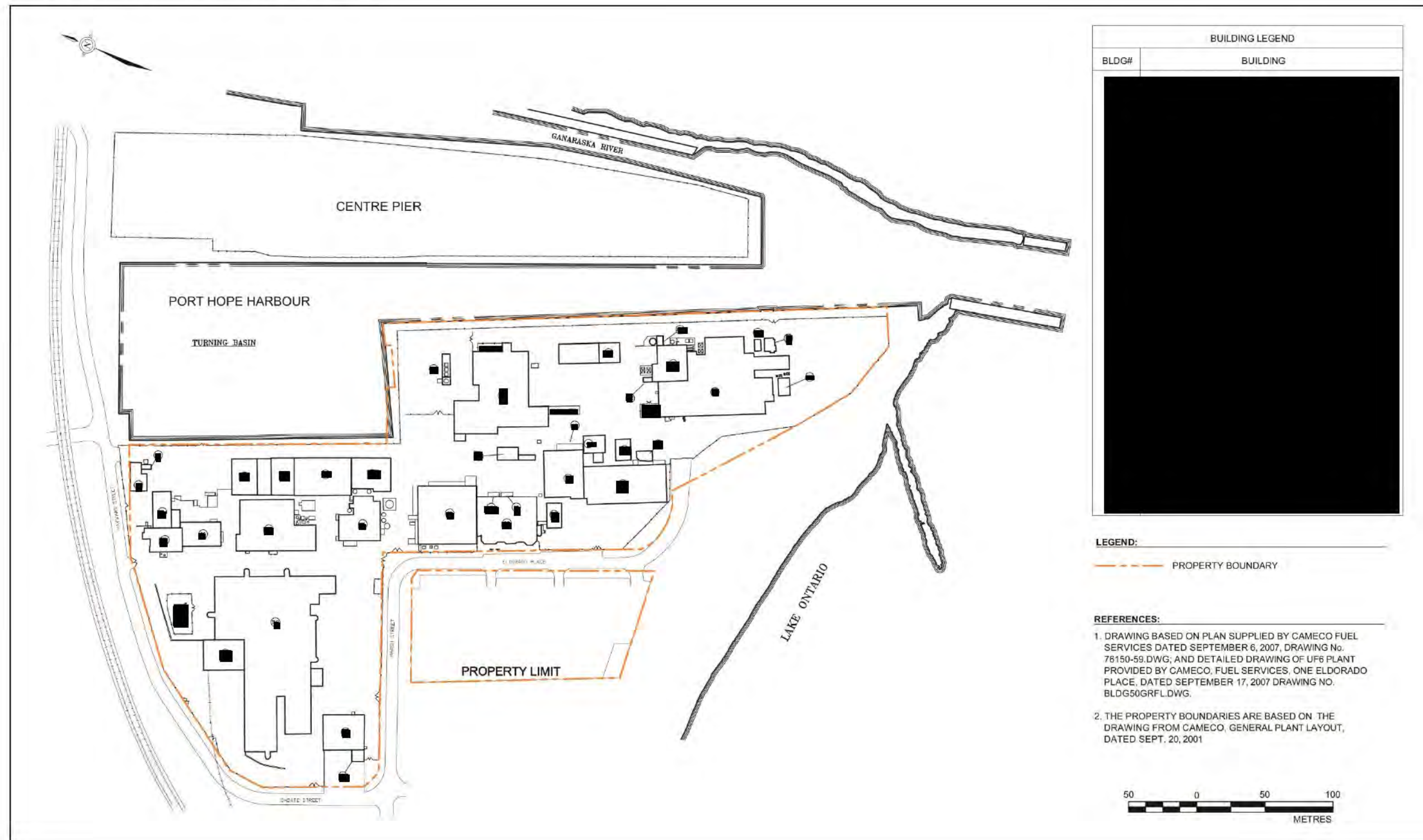

Figure 1.3. UF<sub>6</sub> and UO<sub>2</sub> Process Plants



### Site Characterization

Several site characterization studies have been completed for the PHCF. These include:

- SENES (2003b) *Phase II Environmental Site Assessment* – a large-scale soil and groundwater sampling and analysis study;
- SLI (2007) *Supplementary Environmental Investigation* – additional sampling and analysis, along with contamination delineation and geophysical surveys;
- SLI (2006) *Environmental Investigation – Parking Lot and Water Works* – additional geotechnical investigations focusing on the parking lot and water works areas;
- Cameco (2008) *Update on UO<sub>2</sub> Main Sump* – a subsurface investigation in the area of Building 24 (the UO<sub>2</sub> Plant);
- Golder (2008) *Site-Wide Environmental Investigation Report (SWEIR)* – a comprehensive site-wide soil and groundwater sampling and analysis program;
- SLI (2010a) *Harbour Wall Investigation*;
- SLI (2010b) *Vision 2010: Port Hope Conversion Facility Comprehensive Environmental Site Investigations*;
- Tetra Tech (2013) *Supplemental Geotechnical/Geo-Environmental Field Investigation Report – Vision in Motion Project* – a geotechnical investigation to support early feasibility-level designs related to soil excavation, dewatering, damming, and other engineering works for new structures included in the overall Vision in Motion project.

Several more studies have been completed on the areas surrounding the PHCF, such as the Town of Port Hope, nearby residential and commercial areas, the Port Hope Harbour, and Lake Ontario.

### Environmental Management/Remediation

In response to earlier findings from subsurface investigations, Cameco submitted an EMP (updated EMP) for Building 50 in December 2007 (Cameco 2007). Currently, the PHCF administers a number of environmental programs, initiatives, and studies, which include but are not limited to:

- Environmental Management Program (Cameco 2013);
- Environmental Impacts and Test Plan (Cameco 2010);
- Environmental Monitoring Program (Cameco 2014a);
- Entrainment Monitoring (SENES 2014a); and
- Thermal Monitoring & Risk Assessment (SENES 2014b).

Other environmental management/remediation activities undertaken by Cameco are captured under the Vision in Motion (VIM) project – an ongoing comprehensive redevelopment planned for the PHCF. The VIM project involves activities such as the removal of several old or under-utilized buildings, the removal of

contaminated soils, building materials and stored wastes, transporting those soils and wastes to a long-term waste management facility and constructing associated new infrastructure and building modifications.

#### Risk Assessment

Several risk assessments have been completed for the PHCF. These include:

1. SENES (2004) Environmental Risk Assessment;
2. SENES (2008a) Building 50 Risk Assessment;
3. SENES (2009a) Site-Wide Risk Assessment;
4. SENES (2009b) Site-Wide Risk Assessment Addendum;
5. SENES (2010) Site-Wide Risk Assessment Follow-up Study; and
6. SENES (2013) Fenceline Risk Assessment.

In addition, thermal effects assessments have also been carried out for the PHCF; these are discussed in Section 7.

Items 2 to 5 of the above list function as a continuing study:

Cameco retained SENES to carry out a Building 50 Risk Assessment to evaluate the potential human health and ecological risk associated specifically with the Building 50 event (SENES 2008a). The main conclusions from the B50RA were as follows:

- Implementation of Health and Safety procedures ensures that there is no unacceptable radiological or chemical risk to on-site workers based on exposure to soil and groundwater levels associated with the event as currently mitigated by the updated EMP.
- There is no unacceptable radiological or chemical risk to members of the public from the event under current conditions.
- There is no unacceptable radiological or chemical risk to non-human biota from the event under current conditions.

Following this, Cameco retained SENES to carry out a Site-Wide Risk Assessment (SWRA) focusing on subsurface contamination associated with the facility. The SWRA assessed the exposure of workers, members of the public and ecological biota focussing on contaminants in soil and groundwater associated with the PHCF. The SWRA also provided risk-informed feedback on risk-sensitive information gaps as well as information on the potential need for additional mitigative and preventive measures to ensure that there is no undue risk associated with PHCF operations.

The SWRA was based on information available upon completion of the SWEIR in December 2008 and was prepared between January and June of 2009. The June 2009 deadline was a regulatory commitment. Following the June 2009 deadline, the SWRA was further refined by a series of activities, including

acquisition of additional data. The SWRA was updated by way of the December 2009 SWRA Addendum (SENES 2009b).

In 2010, the SWRA was again updated and expanded following regulatory review and feedback on the June and December 2009 versions. The 2010 update included additional studies such as sediment transport, radon investigation, pump-&-treat evaluation, and an investigation of the potential for recontamination of Harbour sediments following potential remediation.

## 1.2 Present Objective and Scope

Cameco's overall objective is to address the following question based on guidance from the applicable CSA standards and consistent with MOE expectation for such assessments:

Is there potential for significant environmental (i.e. ecological and human health) effects from current emissions associated with Cameco's Port Hope facility operations?

The present study assesses risks from current operations of PHCF on human health and the environment. This particular document has been prepared to facilitate an ERA based on 2014 data, and focuses on data that was available to the project team by Q2 of 2015.

While the PHCF is the main focus of this study, Cameco's warehouse on Dorset Street East (also in Port Hope) is also investigated, as both a potential source and receptor location. Cameco uses the warehouse for interim storage of radioactive by-product materials created by the PHCF operations. The Dorset Street East property is located approximately 1.5 km north-east of the PHCF property. The site is approximately 2.2 ha in size and is surrounded by [REDACTED] security chain link fence (Security Fence). Within the fenced site there are two (~24 m by 90 m) single-storey metal clad buildings (warehouses) containing contaminated non-combustible materials (in drums). As seen in Figure 1.4 below, it is adjacent to a residential neighbourhood.

Figure 1.4. Aerial Photo of Dorset Street East (Warehouse) Site



This particular document considers an existing PHCF SWRA from 2009/2010 and:

1. Encompasses newly acquired data from environmental monitoring, radiological monitoring, and other recent studies (which reflect changes in site usage and emissions); and,
2. Accounts for changes in the documents, guidelines and standards that support the risk assessment (e.g. CSA 2012, N288.6).

The data used in this update were provided by:

- the site characterizations described in Section 1.1; and
- Information received from the PHCF's monitoring programs, including:
  - surface water data;
  - stormwater data;
  - groundwater data;
  - gamma measurements; and
  - air emissions data.

## 1.3 Report Organization

This report is structured as follows, based on the CSA (2012) recommended outline for ERAs:

**Section 2.0** provides a characterization of the PHCF, including a description of the study area, engineered and natural environment, hydrogeology, and data currently available from monitoring programs and site investigations.

**Section 3.0** describes the initial air, groundwater and stormwater modelling undertaken.

**Section 4.0** presents the methodology and results of screening for contaminants of potential concern (COPCs).

**Section 5.0** presents the Human Health Risk Assessment (HHRA), including selection of receptors, conceptual model for HHRA, methodology and results.

**Section 6.0** presents the Ecological Risk Assessment (ERA), including selection of receptors, conceptual model for EcoRA, methodology and results.

**Section 7.0** presents summaries of several separate studies addressing potential effects from a variety of physical stressors (such as temperature and entrainment).

**Section 8.0** summarizes the conclusions and recommendations resulting from this study.

Many areas of uncertainty attend a risk assessment. This is due to the fact that assumptions have to be made throughout the assessment either due to data gaps, environmental fate complexities or in the generalization of receptor characteristics. To be able to place a level of confidence in the results, an accounting of the uncertainty, the magnitude and type of which are important in determining the significance of the results, must be completed. In recognition of these uncertainties, several conservative assumptions were used throughout the assessment to ensure that the potential for an adverse effect would not be underestimated. In each of the major sections above, a sub-section describing uncertainty and conservatism is provided.



## 2 SITE DESCRIPTION

As discussed above, the PHCF is situated on the north shore of Lake Ontario in the Municipality of Port Hope, Ontario. The PHCF is bounded on the west by Choate Road and the Municipality of Port Hope Waterworks, on the north by Hayward Street, and on the east by Port Hope Harbour. The Municipality of Port Hope Waterworks occurs further to the west. The main branch of the Ganaraska River empties into Lake Ontario east of the Harbour. The Centre Pier is bounded by Hayward Street to the north, the Port Hope Harbour to the west, Lake Ontario to the south and the Ganaraska River to the east. The PHCF occupies an area of 9.6 hectares and the Centre Pier 3.8 hectares.

At the PHCF, the ground surface elevation generally increases northward away from Lake Ontario, rising from elevation 78 metres above sea level (masl) near the shoreline to about elevation 86 masl near Hayward Street. The mean lake level of Lake Ontario, and the Port Hope Harbour, is about elevation 75 m. South of the facility, a breakwater exists along the shoreline, and to the east, a steel sheet pile wall (south of the turning basin) and a concrete and timber crib wall (along the turning basin) is present at the edge of the Harbour.

Cameco is currently licensed by the CNSC to store and process various natural, depleted and enriched uranium compounds in order to produce uranium dioxide, uranium hexafluoride, and uranium metal castings. These activities primarily occur in Building 24, Building 50 and Building 2, and are anticipated to continue in the foreseeable future. Cameco has a project underway entitled “Vision In Motion”, which will revitalize the PHCF through: removal of old and/or under-utilized buildings and associated equipment; removal of contaminated soil, building materials and stored wastes; transportation of those soils and wastes to a long-term waste management facility; and constructing associated new infrastructure and building modifications. Consistent with the community planning objectives for the development of the waterfront, land exchanges between Cameco and the Municipality of Port Hope will likely occur during the VIM project.

The Dorset Street East Warehouse is located approximately 1.5 km north-east of the PHCF property. As discussed above, it is approximately 2.2 ha in size and consists of two single-storey metal clad buildings (warehouses) containing contaminated non-combustible materials in drums from the PHCF.

### 2.1 Site History

A Phase I Environmental Site Assessment (ESA, SENES 2003a) provides a detailed summary of the historical activities at the site.

The facility site has been used extensively for industrial purposes for over 100 years, and has undergone significant changes and major redevelopment within that period. Several significant milestones with respect to development on the Site have been identified. These milestones include:

- Industrial use of the site prior to occupancy by Eldorado Mining and Refining Limited (Eldorado) and its predecessor;
- First occupancy of the site by Eldorado in 1932;
- The first major expansion of the original Eldorado facility in the late 1930s, including a steam power plant and a new radium refining facility;

- Reclamation of land on the east half of the south block and subsequent use for stockpiling of coal;
- Construction of a new laboratory facility and Uranium metal plant in 1958/59;
- Re-development of the south portion of the property including construction of the original UF<sub>6</sub> plant and zirconium plant later converted to a UO<sub>2</sub> plant) starting in 1968; and
- Expansion of the north portion of the property and construction of the new UF<sub>6</sub> plant in the northwest corner of the property in the early 1980s.

The recent site history, in the context of the Building 50 event, is summarized in the SWEIR (Golder 2008a). That report describes how Cameco expanded its environmental management activities in 2008, in response to the investigation findings.

## 2.2 Natural and Physical Environment

### 2.2.1 Geology & Hydrogeology

The Phase II ESA (SENES 2003), the Site-Wide Environmental Investigation Report (Golder 2008), the Comprehensive Environmental Site Investigation (SNC-Lavalin 2010b), the Supplemental Geotechnical/Geo-Environmental Field Investigation (Tetra-Tech 2013) and the 2012 through 2014 Annual Groundwater and Surface Water Review reports (Golder 2013a, 2014, 2015) contain detailed discussions of the physical features of the PHCF site, which includes many of the lands that comprise the RA property. These documents were referred to during the preparation of this RA.

A brief summary of the information relevant to the RA property is provided as follows:

#### Geology

As described in the SWEIR (Golder 2008), the PHCF is located in the physiographic region known as the Iroquois Lake Plain. The Iroquois Lake Plain is typically underlain by a thin veneer of beach sands that overlie silty sand to sandy silt tills of glacial origin. The overburden soils range in thickness from about 6 to 12 metres across the site, and are underlain by limestone bedrock that belongs to the Trenton-Black River (Simcoe) Group of limestones. The bedrock surface is relatively flat-lying, dipping to the south, and ranging in elevation from about 69 metres above sea level (masl) to 75 masl.

The local geological conditions across the site have been investigated through numerous subsurface geotechnical investigations, including: geotechnical investigations completed in 1980 in advance of the construction of Building 50 (Golder 1980); the drilling and installation of the Refinery Wells (RW) series monitoring wells in the 1980s; boreholes advanced as part of the Phase II Environmental Site Assessment for the PHCF (SENES 2003); and boreholes advanced during SNC investigations (SNC 2006). According to Golder (2008), the results from each of these programs indicate that the overburden soils are generally comprised of an upper sand and gravel fill, underlain by a compact, dense, silty sand to sandy silt to clayey till present in association with a topographic high centred below Building 50. On the flanks of this topographic high, the till pinches out and is replaced by organic deposits (peat) in the direction of the Harbour, and silty sand in the direction of the parking lot at the corner of Marsh Street and Eldorado Place.

In certain areas beneath Building 50, the till is underlain directly by bedrock. Elsewhere, the till, organic materials and/or silty sand are underlain by sand and sand and gravel (Golder 2008).

### Hydrogeology

Groundwater elevation monitoring in 2012 (Golder 2013a) indicates that the groundwater elevation is approximately 75 masl (metres above sea level), corresponding to the water level in Lake Ontario. Groundwater elevations across the remainder of the PHCF indicate that the general direction of groundwater movement through the overburden soils is toward the east across the site, in the direction of the turning basin and approach channel.

The water table is generally encountered in the till material at a depth ranging from approximately 3.5 to 4.5 metres below the floor surface of Building 50, to approximately 1 metre below ground surface (mbgs) at the south end of the facility. The estimated hydraulic conductivity of each stratigraphic unit is presented in several of the supporting studies mentioned earlier, including Golder (2008a).

The permeability of the overburden soils as inferred from the results of grain size distribution test results, and on the *in situ* rate of groundwater response during previous drilling of boreholes at the site, indicates that the sand and gravel to gravelly sand deposits, which frequently overlie the bedrock, comprise the most permeable soils at the site, with estimated hydraulic conductivities of about 10<sup>-6</sup> m/s to 10<sup>-4</sup> m/s. The silty sand, sand and silt, and silt till soils are relatively less permeable, with estimated hydraulic conductivities ranging from about 10<sup>-8</sup> m/s to 10<sup>-7</sup> m/s. The granular fill which covers much of the site is variable in composition; consequently, its hydraulic conductivity has been estimated to range from approximately 10<sup>-7</sup> m/s to 10<sup>-4</sup> m/s.

Single well response tests on and adjacent to the grass patch area along the harbour wall (Golder 2008) indicate that hydraulic conductivity in the shallow overburden ranges from 10<sup>-6</sup> m/s to 10<sup>-5</sup> m/s adjacent to the western and southern walls of the turning basin, increasing to 6 x 10<sup>-5</sup> m/s to 10<sup>-4</sup> m/s moving south along the approach channel. Deep overburden ranges from approximately 10<sup>-6</sup> m/s to 10<sup>-5</sup> m/s. These *in situ* ranges of hydraulic conductivities are within the ranges estimated for the individual soil units.

Pump test data of two bedrock wells at the southerly portion of the grass patch area (TetraTech 2013) indicate that the weathered limestone bedrock has a hydraulic conductivity of 3.8 to 7.6 x 10<sup>-5</sup> m/s.

As discussed in annual groundwater reports (e.g., Golder 2013a, 2014, 2015), the pump-and-treat system lowers the discharge rate to the Harbour (in comparison to pre-pumping conditions, though the extent of the reduction fluctuates based on pump-and-treat system efficiency).

## **2.2.2 Terrestrial and Aquatic Environments**

As shown in Figure 1.1 to Figure 1.3, the PHCF is located close to the shore of Lake Ontario. Immediately to the east of the PHCF site is a long, narrow strip of grass, followed by the harbour wall, and the Port Hope Harbour. The southern limit of the PHCF site includes shoreline (Lake Ontario). Further east of the Harbour is the Centre Pier, followed by the outlet of the Ganaraska river to Lake Ontario. A railway is located north of the PHCF site, followed by residential lands. The Dorset Street East Site is located north-east of PHCF. As shown in Figure 1.4, it is surrounded by commercial, residential and park areas.

The terrestrial study area included in this risk assessment involves:

1. the PHCF on-site area, consisting of the land and soil among the buildings, infrastructure and auxiliary systems;
2. the off-site grass strip area, consisting of the long and narrow strip of grass east and north of the PHCF site;
3. a representative residential yard environment near the northern limit of the PHCF site;
4. the Dorset Street East on-site area, consisting of the land around the two warehouse building;
5. a representative residential yard environment near the southern limit of the Dorset Street East site;
6. the park lands north of the Dorset Street East site; and
7. the land associated with commercial properties southeast and southwest of the Dorset Street East site.

The aquatic study area included in this risk assessment involves:

1. the Port Hope Harbour, consisting of the channel and the large inner turning basin; and
2. a representative portion of Lake Ontario located near the facility, south of the harbour channel.

These distinct environmental areas are discussed in greater detail in the HHRA and EcoRA sections of this report.

### **2.2.3 Meteorological Statistics and Climate Setting**

#### Temperature

Temperature data for the past 5 years (January 2011 to December 2015) was obtained from the Environment Canada Climate Data website (<http://climate.weather.gc.ca/>) for the Cobourg STP station, deemed the most relevant local station, also used in the surface water modelling. Using this data, the following 5 year statistical temperature information was aggregated for the site:

Min Daily Temperature: -26°C

Mean Daily Temperature: 7.7°C

Max Daily Temperature: 33°C

Mean daily temperatures for this time period are plotted in Figure 2.1.

Final – Environmental Risk Assessment for the Cameco Port Hope Conversion Facility

Figure 2.1. Mean Daily Temperature (2011-2015)

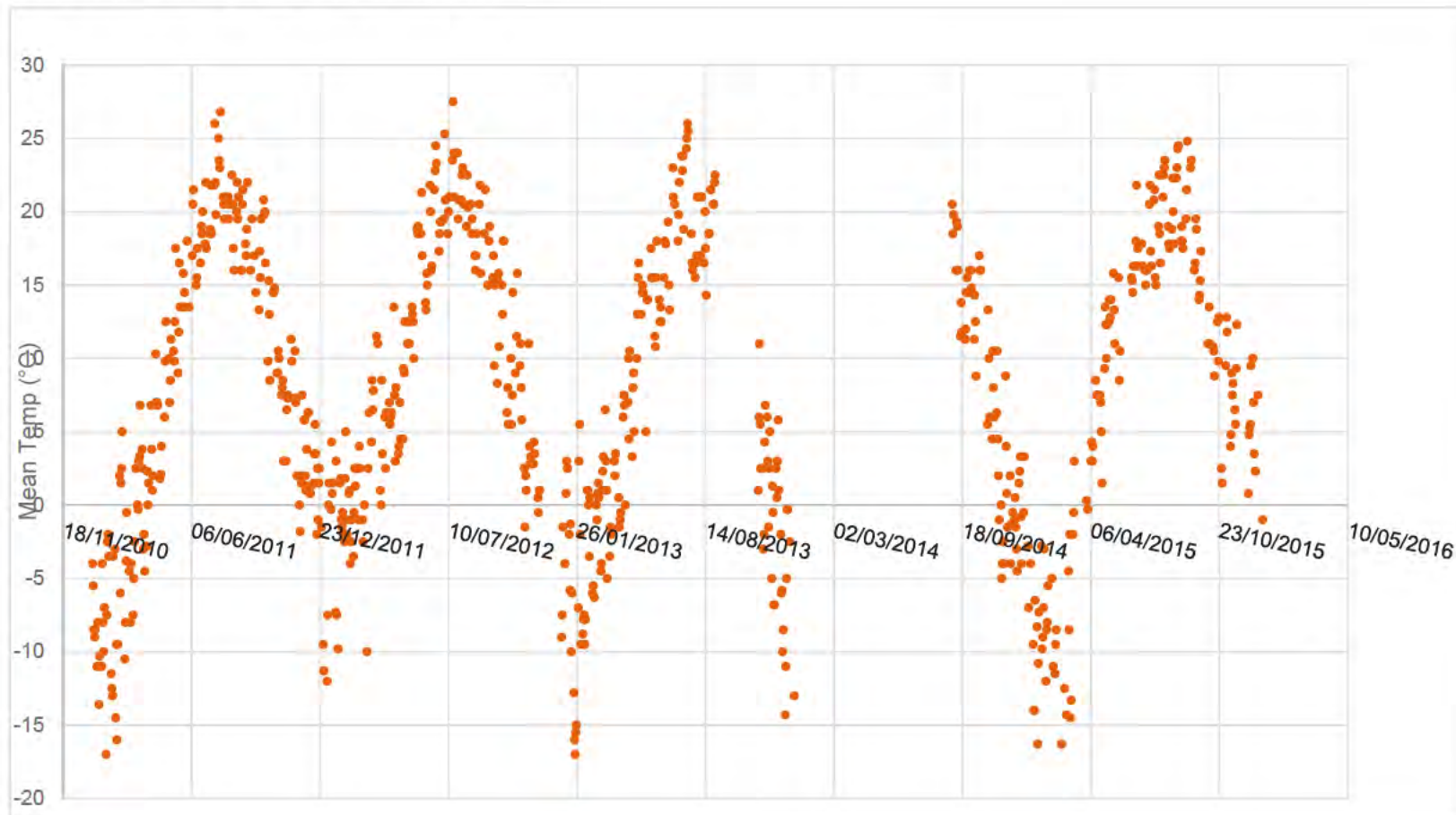

Precipitation

Precipitation data for the past 5 years (January 2011 to December 2015) was obtained from the Environment Canada Climate Data website (<http://climate.weather.gc.ca/>) for the Cobourg STP station, deemed the most relevant local station, also used in the surface water modelling. Using this data, the following 5 year statistical precipitation information was aggregated for the site:

Min Annual Precipitation: 121 mm (2014)

Average Annual Precipitation: 370 mm

Max Annual Precipitation: 634 mm (2011)

Mean daily precipitation for this time period are plotted in Figure 2.2.

Final – Environmental Risk Assessment for the Cameco Port Hope Conversion Facility

Figure 2.2. Total Monthly Precipitation (2011-2015)

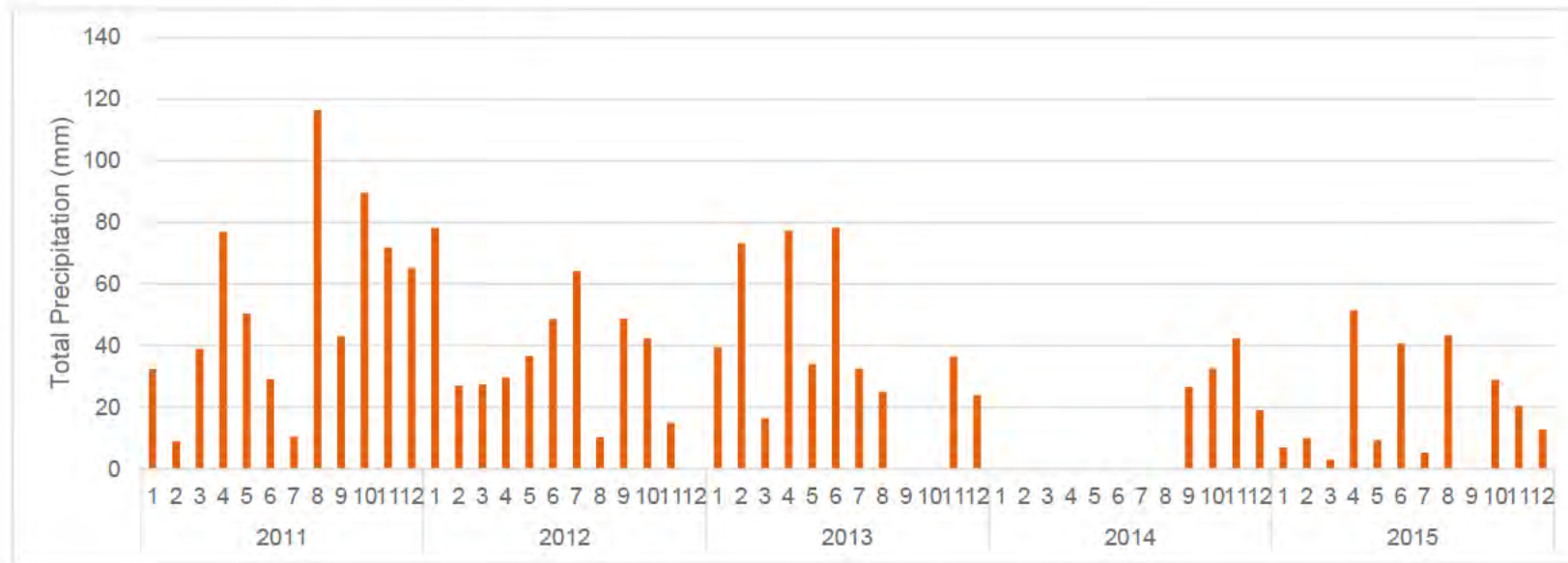

Wind

The closest station having the upper air data necessary for dispersion modelling is the Buffalo, NY Airport station. Missing data in the Buffalo, NY meteorological data set were backfilled with data from the Albany, NY in an effort to minimize modelling anomalies. The mixing height data for each day for the 5-year simulation period (1996-2000) was developed using the AERMET meteorological pre-processor. The albedo, Bowen ratio and surface roughness characteristics were determined for each wind sector and merged with the upper air data from Buffalo (and Albany), and the required surface meteorological data to create hourly mixing heights required by the dispersion model. There were no substantive blocks of data missing from this meteorological data set. The wind rose used for modelling in this assessment is shown in Figure 2.3. As the wind rose used is now a bit dated, a sensitivity analysis was performed on the impact of using wind data from 2010-2014 vs 1996-2000. This is presented in Appendix A, Section A4 and shows no significant impact to the change in wind rose data.

Figure 2.3. Wind Rose for Darlington 1996-2000 Meteorological Data Set

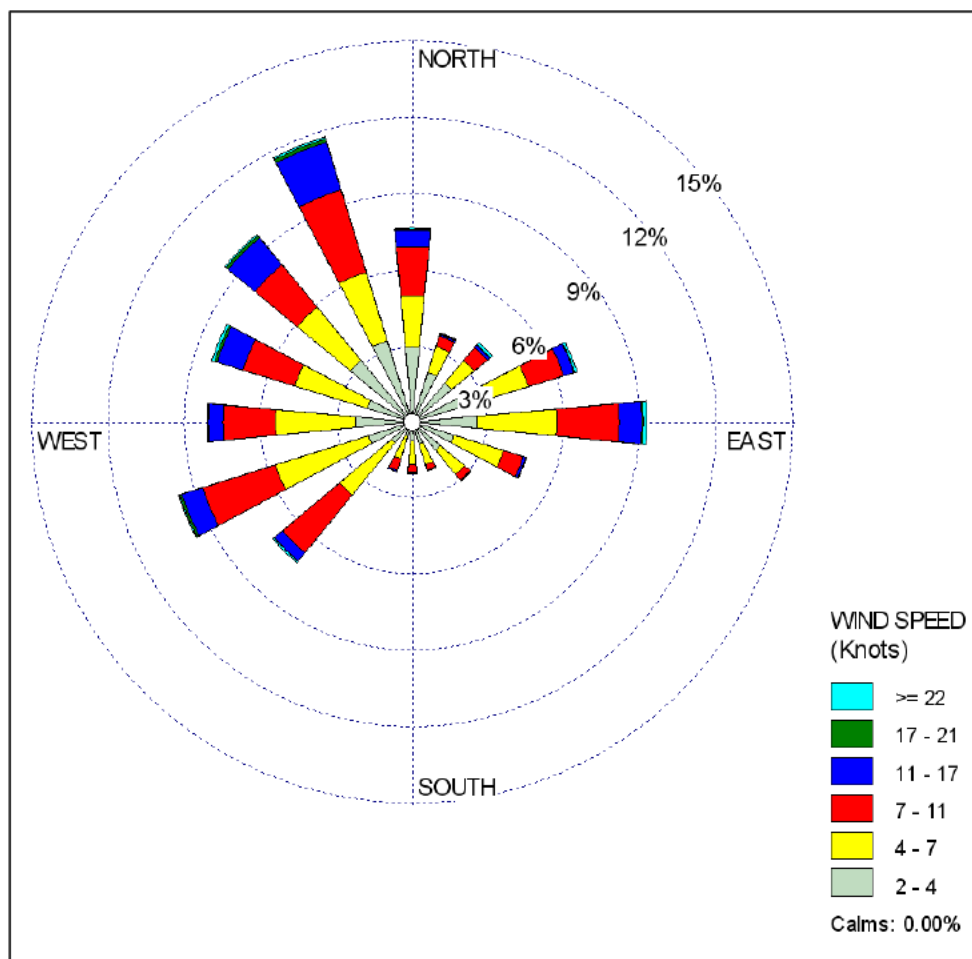

Note: Wind directions shown are winds "blowing from"



## 2.3 Available Environmental Monitoring Data

### 2.3.1 Groundwater Quality Data

The main source of groundwater quality data is the *2014 Annual Groundwater and Surface Water Review Report* (Golder 2015). It includes the data from PHCF's internal groundwater monitoring and analysis for 2014. Groundwater quality data in Golder (2015) encompass several analytes, including several metals, general physical and parameters, major ions, VOCs, and Ra-226.

In addition, data from the 2009 SWRA were used for petroleum hydrocarbons (PHCs), as PHC data are not part of the routine monitoring program and thus were not available in Golder (2015). The SWRA data were from a specific campaign for investigation of analytes potentially associated with leakage or spills. The routine monitoring program is based on contaminants of concern identified in previous investigations.

Mass loadings from groundwater to the Harbour are estimated in the *Annual Groundwater and Surface Water Review Reports*, the most recent of which (Golder 2015) contains estimated 2014 loadings for the following parameters: uranium, arsenic, fluoride, ammonia, nitrate, radium-226, cis-1,2-dichloroethylene, trichloroethylene and vinyl chloride.

### 2.3.2 Soil Quality Data

Soil quality data are available from several past studies, and these data were most recently consolidated as part of the SENES (2013) fenceline risk assessment. Soil data available as of the SENES (2013) study include the following:

- SENES (2003) Phase II Environmental Site Investigation;
- SNC Lavalin (2006a) Site Environmental Investigation;
- SNC Lavalin (2006b) Environmental Investigation of the Parking Lot & Water Works;
- LLRWMO (2007);
- Golder (2008) Site Wide Environmental Investigation Report (SWEIR);
- SENES (2008b) Soil Characterization and Evaluation Study at Port Hope;
- SENES (2009a) SWRA: Cameco sampling data (U-236 campaign, 2008; hardcopy received from Cameco);
- SENES (2009b) SWRA: soil and grass radiological sampling campaign;
- SLI (2010a) Harbour Wall Investigation;
- Geo Logic (2010) supplemental soil sampling as part of SLI (2010); and
- Tetra-Tech (2013) Supplemental Geotechnical/Geo-Environmental Field Investigation Report.

The quantity and range of soil data vary by location, but overall soil data include: fluoride, nitrate (as N), nitrite (as N), ammonia, major anions (for example bromide and chloride), metals, volatile organic carbons

(VOCs), petroleum hydrocarbons (PHCs), polychlorinated biphenyls (PCBs), and radionuclides (see Section 2.3.7).

The present study uses the consolidated on-site soil data set from SENES (2013), which includes data from the above references. The 2011 PHCF Soil Monitoring Program Review (SENES 2011a) showed that deposition to soil is not significant and is not expected to change soil concentrations significantly over time.

In addition to the above on-site (or near-site) soil data, Cameco conducts annual soil sampling at specified off-site locations in Port Hope. Cameco provided data from the 2014 monitoring program; these results are used in the assessment of risk to off-site receptors, in the present study.

### **2.3.3 Surface Water Quality Data**

As part of its monitoring program, Cameco samples surface water and obtains analysis for six analytes: Ra-226, arsenic, uranium, nitrate (NO<sub>3</sub>), fluorides, and total ammonia (NH<sub>3</sub>+NH<sub>4</sub>). Results were obtained from quarterly sampling activities conducted in 2014 (March, June, September, and October). Therefore, approximately 5 individual measurements are available for each of the six analytes, from several monitoring stations. Furthermore, data are divided into two categories based on depth, with one set of measurements representing conditions at 0.5 m below the surface, and a second set of measurements representing conditions at the lake bottom (i.e., just above the sediment layer).

All 2014 surface water data are included in the present risk assessment update. The 2014 data are from Cameco's internal monitoring program, and are available only for select analytes as described in the Environmental Monitoring Plan; previous years of internal monitoring also cover only select analytes. Therefore, an older data set was drawn upon to supplement these 2014 data. The most recent study with a comprehensive surface water data set was the 2009 SWRA (SENES 2009); this data set was used to provide information on additional analytes (e.g., radionuclides, additional metals, VOCs, and general chemistry). The 2009 data set was developed in a specific, non-routine campaign as part of the Building 50 leakage investigation. As the 2009 data set was part of an investigation, a more comprehensive set of analytes was assessed. The routine program focuses on specific contaminants of concern determined through previous investigations.

### **2.3.4 Sediment Quality Data**

Sediment quality data are available from several past studies, and these data were most recently consolidated as part of the 2009 SWRA (SENES 2009) and its related follow-up investigations. The SENES (2009) SWRA's sediment data were obtained from:

- Cameco sampling data (Harbour sediment campaign, May 2008);
- PHAI 2008 Sediment Report (LLRWMO 2008);
- PHAI 2007 Harbour Report (LLRWMO 2007b); and
- SGP (2003) Sediment Report.

Overall, based on the SENES (2009) SWRA compilation, sediment data consists of:

- Metals (including uranium, arsenic, chromium, and others);
- Radionuclides (including Ra-226, U-235, Pb-201, and others); and
- Polyaromatic Hydrocarbons (PAHs) (including naphthalene, pyrene, and others).

Given that the sediments in the harbour will be remediated as part of the Port Hope Area Initiative, Cameco does not presently collect sediment samples as part of the routine monitoring program. The consolidated sediment data from the June 2009 SWRA are used for the present risk assessment update.

### 2.3.5 Air Quality and Noise Data

The air quality data considered in this study and used in the air dispersion modelling were supplied by Cameco, as follows:

- the emission rates used in the model *other than the UF<sub>6</sub> main stack (ID 0201) and the UO<sub>2</sub> main stack (ID 0401)* are equivalent to the emission rates outlined in the PHCF's 2013 ESDM Report, as characterized in Cameco's *Written Summary for Reporting Year 2013 – Basic Comprehensive Certificate of Approval (Air & Noise)* (Cameco 2014). Emissions to air, extracted from this report, are summarized and screened for COPCs in Section 4;
- the emission rates for the UF<sub>6</sub> and UO<sub>2</sub> main stacks were based on 2014 average annual stack testing results provided by Cameco;
- the source characteristics (e.g., stack height, stack diameter, flow rate, etc.) and building configurations were based on modelling work that was performed by Arcadis as part of the Vision in Motion project in February 2015. As part of this project, the source and building configurations were updated to reflect the most recent noise model which is itself based on measurements that have been collected during multiple site visits completed by Arcadis. As a result, the source and building configurations used in this assessment are considered to be accurate and up-to-date; and
- as mentioned in the previous bullet, the most recent noise modelling was carried out by Arcadis in February 2015 as part of the Vision in Motion project. Arcadis updates the noise model on an on-going basis, to account for facility changes such as the addition of exhaust fans.

With regards to arsenic emissions to air from the PHCF, Cameco has restricted the arsenic levels in the chemicals used at the PHCF. [REDACTED]

### 2.3.6 Stormwater Quality Data

Recent stormwater quality data for the PHCF are available from two sources:

- i) Cameco in-house sampling approximately twice annually, including April and December 2014. Samples are analyzed for inorganics, metals, PHC and BTEX (Benzene, Toluene, Ethylbenzene and Xylene), Ra-226 as well as toxicity tests; and

- ii) 2011 *Stormwater Control Study* (Golder 2011), Appendix B5, which includes 2009-2010 data on VOCs.

Stormwater loadings data are available from the 2011 *Stormwater Control Study* (Golder 2011).

Stormwater quality and loadings data encompass stormwater releases from several on-site sources. It is important to note that as part of continual improvement activities, storm sewer outlets 1, 3, 10 and 12 were abandoned (sealed) in 2014 (Cameco 2015).

The present ERA update is based on recent 2014 stormwater quality data, along with radionuclide and loadings data from the *Stormwater Control Study* (Cameco 2011) where required.

### 2.3.7 Radionuclide & Gamma Measurement Data

Monthly gamma measurements are available from Cameco, for January to December of 2014. Data encompass 33 monitoring locations, including the critical receptor location (station 14). In addition, Cameco has provided 2014 annual average gamma monitoring results for the PHCF and Dorset Street East site (Site 1 and Site 2 respectively).

With respect to gamma sources, Cameco provided some information on the source locations and material types at Centre Pier and Dorset Street. Assumptions were made based on this information, to complete the gamma portion of the DRL.

Cameco provided 2014 total effective dose and dose components to workers at PHCF, broken down by group/ department at PHCF.

Data characterizing radionuclide levels in soil, groundwater, surface water, and sediment were obtained from prior studies; namely, the SENES 2009 December SWRA and the SENES 2013 Fenceline Risk Assessment. Radionuclide data for stormwater are obtained from Golder (2011).

Table 2.1 summarizes the overall availability of radionuclide data across the different environmental media; however, it is important to note that radionuclide data vary by location. For example, while overall surface water data includes several radionuclides much of this is for the Harbour location, whereas only Ra-226 data are available for the West Beach area. Similarly, radionuclide data are available for on-site soil, but only in non-accessible areas. As noted in the table, select, minor data gaps can be filled as follows:

- by assuming that levels of one radionuclide are equal to those of another, based on secular equilibrium; or
- by taking into account the specific activity of natural uranium to estimate U-238, U-234 and U-235 concentrations; or
- estimating concentration using a sediment-water distribution coefficient (Kd).

Major data gaps cannot be filled without additional monitoring activities; these are noted with “ND”, indicating no data available.

Table 2.1 Availability of Measured Radionuclide Data

	Pb-210	Po-210	Ra-224	Ra-226	Ra-228	Th-228	Th-230	Th-232	U-234	U-235	U-238
<b>Air</b>	-	-	-	-	-	-	-	-	Estimated from natural U ( $U_{nat}$ )		
<b>Soil (On-Site)</b>	✓	✓	Assumed equal to Ra-228	✓	✓	✓	✓	✓	Estimated from $U_{nat}$	✓	✓
<b>Soil (Off-Site)</b>	✓	✓	Assumed equal to Ra-228	✓	✓	✓	✓	✓	Estimated from $U_{nat}$	Estimated from $U_{nat}$	✓
<b>Ground water</b>	✓	✓	Assumed equal to Ra-228	✓	✓	✓	✓	✓	✓	✓	✓
<b>Surface water</b>	✓	✓	✓	✓	Assumed equal to Ra-224	✓	✓	✓	✓	✓	✓
<b>Sediment</b>	✓	Assumed equal to Pb-210	Estimated from surface water using $K_d$	✓	Estimated from surface water using $K_d$	Estimated from surface water using $K_d$	✓	Estimated from surface water using $K_d$	Estimated from $U_{nat}$		
<b>Storm water</b>	✓	✓	Assumed equal to Ra-228	✓	✓	✓	✓	✓	✓	✓	✓

Notes:

✓ indicates where measured data are available for a particular radionuclide.

' - ' indicates where measured data are not available for a particular radionuclide.

### 2.3.8 Uncertainties in Site Description

Due to the large number of environmental studies conducted by Cameco, the site is well-characterized and there are few uncertainties or data gaps with respect to site description. Because the study period of this ERA was 2014, there were some data gaps identified; however, these were addressed by making conservative assumptions, such as the following:

- For both groundwater and surface water, the 2014 data set, from Cameco's quarterly internal monitoring program, was used preferentially; however, the Cameco internal monitoring covers a limited number of analytes. The data set was therefore infilled from the most recent available comprehensive data set. As discussed above, supplementary groundwater data were obtained from Golder (2015) and SENES (2009a). Similarly, the surface water data set from Cameco's internal monitoring program was infilled with data from SENES (2009a). *Degree of uncertainty: Low*
- Substantial soil data were available from a number of studies. Where possible, the most recent data were used. The data set was then infilled with data from additional studies, using conservative assumptions such as using the maximum concentration from all depths of sample. *Degree of uncertainty: Low*
- As discussed in Section 2.3.7 above, some radiological data gaps were identified. These typically related to the number of radionuclides monitored, and the geographic distribution of monitoring results. In order to fill minor data gaps, methods such as specific activity (e.g., to estimate U-234, U-235 and U-238 from natural uranium), sediment-water equilibrium (e.g., to estimate sediment concentrations from known water concentrations) and secular equilibrium (e.g., to assume radionuclide concentrations based on other radionuclide levels) were used. It is difficult to estimate the amount of conservatism in these assumptions; however, considering that they are based on maximum or 95% UCLM concentrations, it is unlikely that the resulting dose estimates would be underestimated. *Degree of uncertainty: Medium*

Other data gaps (such as air, soil and gamma levels at off-site receptor locations) were addressed by undertaking modelling activities; this is further discussed in Section 3.

## 3 MODELLING

### 3.1 Modelling Air Releases

In 2015, Arcadis carried out air dispersion modelling of uranium emissions from the PHCF, using the AERMOD dispersion model, to determine annual average air concentrations and deposition rates. Concentrations and deposition rates were estimated for both the standard Ontario Ministry of Environment and Climate Change (MOECC) model receptor grid as well as discrete receptor locations. The results predicted at discrete receptor locations were provided as inputs to the present risk assessment.

The air dispersion modelling was completed in accordance with the MOECC document “Air Dispersion Modelling Guideline for Ontario (ADMGO), Version 2.0” dated March 2009. A detailed description of the air dispersion modelling is presented in Appendix A. The modelling results are summarized briefly below.

#### 3.1.1 Sources

The uranium emission rates used in the modelling were supplied by Cameco. Except for the UF<sub>6</sub> main stack (ID 0201) and the UO<sub>2</sub> main stack (ID 0401), uranium emission rates used in the model are equivalent to the emission rates outlined in the facility’s 2013 ESDM Report. Emission rates for the UF<sub>6</sub> and UO<sub>2</sub> main stacks were based on 2014 average annual stack testing results provided by Cameco.

Source characteristics (e.g., stack height, stack diameter, flow rate, etc.) and building configurations were based on modelling work that was performed by Arcadis as part of the Vision in Motion project in February 2015. As part of this project, the source and building configurations were updated to reflect the most recent noise model which is itself based on measurements that have been collected during multiple site visits completed by Arcadis. As a result, the source and building configurations used in this assessment are considered to be accurate and up-to-date.

#### 3.1.2 Receptors

Receptors were chosen based on recommendations provided in Section 7.1 of the ADMGO. Specifically, a nested receptor grid, centered on the emissions sources was used. Receptors were also placed every 10 metres along the property line in accordance with the ADMGO. In addition to the MOECC grid, discrete sensitive receptors were also included in the model. The model results predicted at this group of receptors were provided as inputs to this risk assessment.

Discrete receptors were also placed at the locations of the Hi-Volume air samplers and dustfall jars in Cameco’s Environmental Monitoring Program. Model results predicted at these monitoring locations were used for model validation (see Section 3.2).

#### 3.1.3 Model Results

Model predicted annual average uranium concentrations across the modelling domain are presented in Figure 3.1. All concentrations are below the annual average standard/criterion of 0.03 µg/m<sup>3</sup>. The highest

predicted concentration is 0.0045 µg/m<sup>3</sup> at 15% of the uranium standard. As can be seen in Figure 3.1, the overall maximum uranium concentration is located along the southern portion of the modelled property boundary to the west of the UO<sub>2</sub> main stack (green marker).

In addition, Table 3.1 shows the model predicted uranium concentrations at each of the risk receptor locations.

Table 3.1 Model Predicted Average Annual Uranium Concentrations (µg/m<sup>3</sup>) at the Risk Receptors

Receptor ID	Location Type	Easting	Northing	Annual Average Concentration (µg/m <sup>3</sup> )
<b>Maximum</b>	<b>Fenceline receptor</b>	<b>717204</b>	<b>4869003</b>	<b>4.50E-03</b>
REAH	Residential	716728	4869208	1.87E-03
REAS	Residential	716875	4869414	7.80E-04
FWC2	Fenceline walker	716950	4869302	1.26E-03
FWA1	Fenceline walker	716895	4869128	2.17E-03
COI1	Commercial	716943	4869093	2.07E-03
COI2	Commercial	716969	4869096	2.29E-03
FW12	Fenceline walker	717008	4869145	3.06E-03
FWD2	Fenceline walker	717115	4869240	3.28E-03
RFED2	Recreational fisher	717110	4869254	3.06E-03
FWD1	Fenceline walker	717045	4869379	1.09E-03
RYED1	Recreational yacht club	717090	4869355	1.31E-03
RYED4	Recreational yacht club	717086	4869388	1.07E-03
RYED3	Recreational yacht club	717143	4869378	1.31E-03
RYED5	Recreational yacht club	717140	4869417	1.03E-03
FWJ6	Fenceline walker	717231	4869282	2.02E-03
FWJ1	Fenceline walker	717257	4869427	1.29E-03
FWJ2	Fenceline walker	717307	4869323	1.71E-03
FWJ2	Fenceline walker	717320	4869293	1.60E-03
FWJ4	Fenceline walker	717330	4869262	1.54E-03
RFJ2	Recreational fisher	717395	4869249	1.43E-03
REMM2	Residential	717394	4869330	1.43E-03
COJ2	Commercial	717366	4869345	1.50E-03
COJ1	Commercial	717361	4869399	1.35E-03
RFEDp1	Recreational fisher	717278	4869434	1.27E-03
CODp2	Commercial	717328	4869465	1.12E-03
CODp1	Commercial	717312	4869534	8.30E-04



Final – Environmental Risk Assessment for the Cameco Port Hope Conversion Facility

Receptor ID	Location Type	Easting	Northing	Annual Average Concentration (µg/m³)
FW99/FWF1	Fenceline walker	717239	4869160	2.24E-03
FWF2	Fenceline walker	717259	4869120	2.16E-03
FWF4	Fenceline walker	717286	4869066	2.43E-03
FWJ8	Fenceline walker	717321	4869099	1.97E-03
FWG1	Fenceline walker	717329	4868902	2.15E-03
FWH1	Fenceline walker	717230	4868989	3.89E-03
FWH3	Fenceline walker	717165	4869003	3.41E-03
REDWNW	Residential	718056	4870323	1.90E-04
REDWNW2	Residential	718002	4870235	2.10E-04
RPK1	Residential - park	718097	4870469	1.60E-04
COK1	Commercial	718135	4870148	2.60E-04
COK2	Commercial	718285	4870271	2.30E-04
REDWE	Residential	718415	4870317	2.10E-04
REDWSE	Residential	718266	4870130	2.60E-04
COA1	Commercial	716867	4869148	2.43E-03
REDWSE2	Residential	718311	4870176	2.50E-04

Final – Environmental Risk Assessment for the Cameco Port Hope Conversion Facility

Figure 3.1. Annual Average Uranium Concentrations ( $\mu\text{g}/\text{m}^3$ )



### 3.1.4 Calculation of Deposition Velocity

For use in the Arcadis soil deposition and leaching model [REDACTED] a deposition velocity was calculated and applied to the model predicted uranium concentrations. A deposition velocity was calculated using PHCF monitoring data. Specifically, data from hi-volume particulate samplers co-located with dustfall jars was used from the following Cameco monitoring stations: Station 1 (Waterworks); Station 9 (Shuter St.); Station 10 (Hayward St.); and Station 15 (Marsh St.).

The calculated deposition velocities are shown below in Table 3.2.

Table 3.2 Calculated Deposition Velocities

Month	Deposition rate, cm/s			
	Waterworks (Station 1)	Shuter St (Station 9)	Hayward St (Station 10)	Marsh St (Station 15)
1	1.51	1.78	0.00	1.66
2	0.00	0.00	0.00	0.00
3	2.54	3.73	3.31	2.07
4	0.00	3.39	4.01	2.81
5	Missing	15.81	8.61	11.37
6	5.40	17.86	7.86	9.82
7	12.31	6.78	6.00	3.67
8	2.19	5.14	3.06	3.48
9	0.00	6.39	0.00	5.23
10	9.08	5.54	8.86	3.81
11	3.38	0.00	3.18	2.16
12	2.77	3.22	2.73	5.34
Station Average	3.6	5.8	4.0	4.3
Overall Average	4.4			

### 3.1.5 Comparison: Model vs. Monitoring Data

To evaluate the performance of the AERMOD model, predicted concentrations and deposition rates were compared to PHCF 2014 monitoring data. The comparison of concentrations are shown in Table 3.3 and the comparison of deposition rates are shown in Table 3.4. With the exception of the Shuter St. dustfall station (refer to Table 3.4), predicted uranium concentrations and deposition rates are within a factor of 2 of monitored data. A model is considered to perform well if the model results are within a factor of 2 of observed values (U.S.EPA 2003). Predicted deposition rates can be more difficult to compare, as the siting of the dustfall jars in close proximity to roads, like the Shuter St. dustfall monitor, may confound the model predictions.

Overall, based on these results, the model is considered to perform well.

Table 3.3 Comparison of Modelled vs. Monitored Uranium Concentrations

Hi-Vol Monitoring Station	UTM Coordinates		Annual Concentration ( $\mu\text{g}/\text{m}^3$ )		
	Easting (m)	Northing (m)	Observed-2014	AERMOD	Ratio Mod/Obs.
Waterworks	716890	4869025	1.87E-03	1.65E-03	0.9
Shuter Street	717612	4869638	1.34E-03	6.70E-04	0.5
Hayward Street	716949	4869293	1.79E-03	1.35E-03	0.8
Marsh St.	716999	4869157	2.44E-03	3.70E-03	1.5

Table 3.4 Comparison of Modelled vs. Monitored Uranium Deposition Rates

Dust Fall Monitoring Station	UTM Coordinates		Annual Deposition ( $\text{mg}/\text{m}^2$ /30 days)		
	Easting (m)	Northing (m)	Observed-2014	AERMOD	Ratio Mod/Obs
Waterworks	716890	4869025	0.17	0.19	1.1
Alexander St. (west end)	716632	4869081	0.22	0.18	0.8
Analytical Roof DF	717043	4869312	0.23	0.35	1.5
Mill St.	717430	4869455	0.18	0.13	0.8
South Fence	717392	4868884	0.26	0.21	0.8
Shuter St.	717612	4869638	0.20	0.08	0.4
Station 10, Fence N of UF <sub>6</sub>	716946	4869284	0.19	0.19	1.0
Marsh St.	716999	4869157	0.28	0.42	1.5

### 3.2 Modelling Off-Site Soil Concentrations

Uranium levels in off-site residential soil are required for subsequent risk calculations. Cameco collects off-site soil data at soil monitoring stations located throughout the area surrounding the PHCF. SENES (2011a) consolidated soil data from prior detailed studies and presented soil concentration trends at each soil monitoring location. Based on the recommendations from SENES (2011a), Cameco currently monitors soil concentrations at five stations, numbered as follows and shown in Figure 3.2:

- Station 1, located west of the facility;
- Station 2, located west of the facility;
- Station 12, located north of the turning basin;

- Station 19, located north and east of the PHCF and Ganaraska River, towards the Dorset Street East Site; and
- Station 25, located east of the PHCF and the Ganaraska River, along Lake Ontario.

For each off-site human receptor location (see Section 5.1.1 for discussion), one of the above stations (or in some cases, a combination of two stations) was selected as a representative location. The selections are shown in Table 3.5, with supporting rationale. Based on these selections, incremental soil concentrations - representing the amount of uranium accumulated annually as a result of emissions from the PHCF - were estimated using the air modelling results from Section 3.1 and the Arcadis soil deposition and leaching model [REDACTED]. The resulting incremental soil concentrations are also presented in Table 3.5, along with the station-specific source of soil parameters (e.g. moisture content, bulk density, Kd, etc.). [REDACTED]

Final – Environmental Risk Assessment for the Cameco Port Hope Conversion Facility

Table 3.5 Off-Site Soil Modelling and Results

Offsite Receptor ID (Details in Section 5.1.1)	Corresp. Soil	Monitoring Station – 2014 Soil Data	Corresp. Soil	Monitoring Station – Soil Parameters <sup>a</sup>	2014 Measured Soil U (µg/g)	2014 Modelled U-in-Air Concentration (µg/m <sup>3</sup> ) (Section 3.1)	2014 Modelled Incremental Soil U Concentration (µg/g) [2.5 cm surface depth]
<b>REDWSE</b> (Dorset St.)	19	The nearest soil monitoring locations are station 19 and 25. Station 19 is used preferentially because it is located approx. 525 m W, whereas station 25 is located approx. 660 m SW.	3-10	Soil location '3-10' and '3-8' soil locations are located closest to the receptor location. Though soil location '3-8' is slightly closer to the receptor location, soil location '3-10' is located immediately adjacent to Cameco's corresponding monitoring location #19. Since data from Cameco location #19 are used in the HHRA, parameters from the corresponding '3-10' location are chosen preferentially because they offer the best match to the data used.	1.7	2.60E-04	0.01
<b>REAH</b> (Hayward St.)	1 & 2 Combined Dataset	The closest soil monitoring locations are stations 1 and 2. The distances between the REAH receptor locations and the monitoring stations are quite similar (approx. 260 m and 275 m).	1-12	For location-specific soil parameters, the '1-12' soil location was chosen because – among soil sampling areas where site-specific soil parameters are available – it is located closest to the receptor location.	5.9	1.87E-03	0.08
<b>REMM</b> (Madison St.)	12 & 25 Combined Dataset	The closest soil monitoring locations are station 12 (approx. 475 m NW) and station 25 (approx. 525 m NE). A combined dataset is used due to the similar distances involved with these two locations.	1-6	For location-specific soil parameters, the '1-6' soil location was chosen because – among soil sampling areas where site-specific soil parameters are available – it is located closest to the receptor location.	7	1.43E-03	0.06

Notes:

<sup>a</sup> SENES (2008).

Final – Environmental Risk Assessment for the Cameco Port Hope Conversion Facility

Figure 3.2. Cameco Off-Site Soil Sampling Locations



### 3.3 Modelling Groundwater & Stormwater Loadings to Surface Water

Arcadis used its Port Hope Harbour model, created for previous aquatic modelling projects, to simulate the plumes from stormwater and groundwater discharges to the harbor and nearshore Lake Ontario, in order to estimate the concentration in surface water as a result of stormwater and groundwater loadings.

The contaminants modelled were: ammonia, arsenic, fluoride, uranium, zinc and radium-226. The modelling details are [REDACTED] summarized below.

#### 3.3.1 Approach

##### 3.3.1.1 Groundwater Discharges

Groundwater discharge estimates for 2014 were taken from the Golder (2015) 2014 Annual Groundwater and Surface Water Review report, which divides the harbour wall adjacent to the PHCF into 9 spatial areas and provides estimated groundwater flows (into the harbour) in m<sup>3</sup>/d for each area. These areas are shown in Figure 3.3. Discharge estimates based on 2014 average pumping rates were selected. The annual loadings estimated in Golder (2015) for Areas 1 through 8 were used. Golder (2015) does not calculate mass loadings from Area 9 because they are expected to be negligible, due to the low discharge rates from Area 9 to the lake and the water quality in proximity to the lake. However, for the present groundwater modelling, Arcadis estimated groundwater loadings from Area 9, based on 2014 measured groundwater concentrations at monitoring wells near Area 9, and the estimated mass discharge rate from Figure 3.3. Area 9 is along the west shoreline, and the flow was split by a third and distributed over 3 grid points.

Table 3.6 presents the groundwater discharge inputs used. Figure 3.3 outlines the locations of the groundwater discharge zones based on Golder (2015). Figure 3.4 shows the groundwater discharge areas, as represented in the model.

##### Calibration of the Groundwater Model

As described in the Golder (2015) groundwater modelling report, the groundwater model used to provide simulations for the PHCF site is a 3D numerical finite difference model constructed using MODFLOW. This groundwater model is based on the conceptual model – including generalized hydrostratigraphic units, flow directions, and approximate rates of travel – as well as the updated environmental monitoring program for the site. The model simulates the distribution of hydraulic heads (i.e. groundwater elevations) and seepage rates within the groundwater flow system based on the assumption that groundwater flow is in accordance with Darcy's Law for equivalent porous media. Since 2007, the groundwater model for the site has been refined and updated as more geological and hydrogeological data are collected (typically annually, for most types of data), steadily increasing the overall confidence in its predictive abilities. The calibration targets considered in developing confidence in modelling predictions, and an indication of the results for the PHCF groundwater model, are as follows:

- Comparison between simulated and measured groundwater elevations: this is the standard statistical plot used in evaluating the reasonableness of the match between simulated and field-measured groundwater elevations. For the 2014 version of the model (the most recent version,



calibrated with the most recent – 2014 – measured data), the number of observation locations is 217 and the normalized root mean square is 5.25%

- **General Consistency with Groundwater Flow Patterns:** The model calibration process incorporates the consistency between the observed groundwater flow directions with those simulated by the model, as well as consideration of any observed plume development. Overall, the flow patterns generated by the model provide good representation of flow patterns and of the two plumes associated with Building 50 when compared against field-measured data.
- **Consistency with Pumping Test Results:** Locally, the model is calibrated to the results from several pumping tests, including TW1, TW2b, TW2c, TW3, TW4, TW6, TW7, TW9, TW27a and TW27b. Therefore, as indicated in Figure 3.3, *all* of these calibration stations are included in the discharge estimates from the harbour wall areas.

Table 3.6 Groundwater Discharges

Groundwater Discharge Area	Model source location		Flow (m <sup>3</sup> /s)	Groundwater Concentration					
	column	row		U	F	Ammonia	As	Ra	Zn
			(mg/L)	(mg/L)	(mg/L)	(mg/L)	(Bq/L)	(mg/L)	
1	1	75	2.59E-4	0.37	0.319	8.84	0.193	0.0538	1.58E-2
2	1	68	2.49E-5	2.32	4.25	12.6	0.206	0.123	9.33E-3
3	1	59	1.22E-5	0.29	11.1	13.5	0.225	0.0821	2.17E-3
4	10	55	1.46E-5	0.14	5.8	4.82	0.17	0.0825	1.65E-2
5	10	45	2.55E-5	0.0222	2.67	1.87	0.057	0.0324	6.5E-3
6	10	35	3.01E-6	0.048	0.125	1.44	0.004	0.0244	4E-3
7	10	19	4.63E-7	0.426	1.87	81.5	0.022	0.228	1.05E-2
8	10	5	1.89E-5	0.00219	0.163	3.74	0.0092	0.0317	1.1E-2
9	11	11	5.2E-6	5.46E-2	3.73E-2	3.17E-1	6.25E-1	5.5E-2	1.3E-3
9	9	11	5.2E-6	5.46E-2	3.73E-2	3.17E-1	6.25E-1	5.5E-2	1.3E-3
9	7	11	5.2E-6	5.46E-2	3.73E-2	3.17E-1	6.25E-1	5.5E-2	1.3E-3

Figure 3.3. Groundwater Discharge Areas and Estimates (Golder 2015)

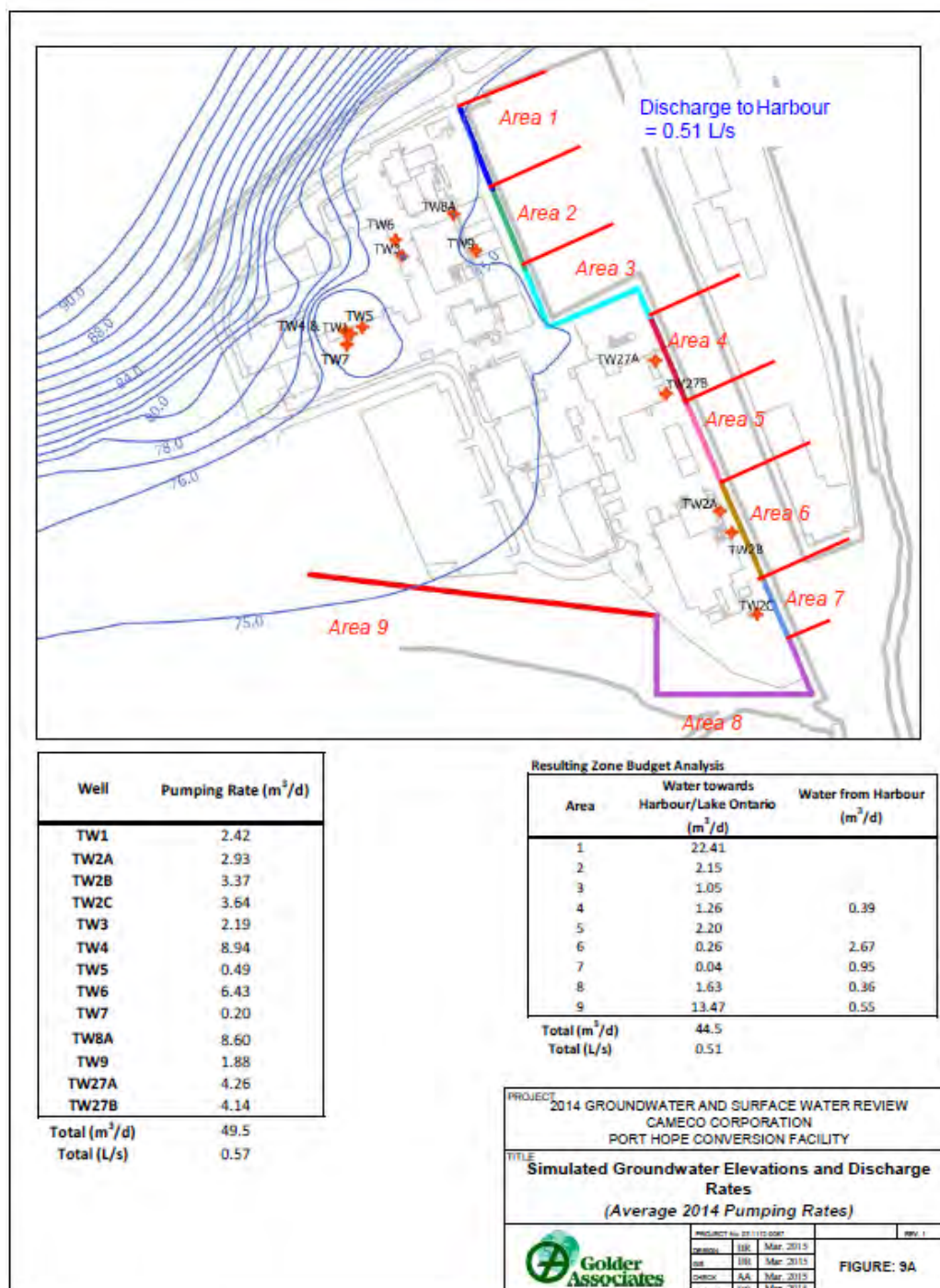
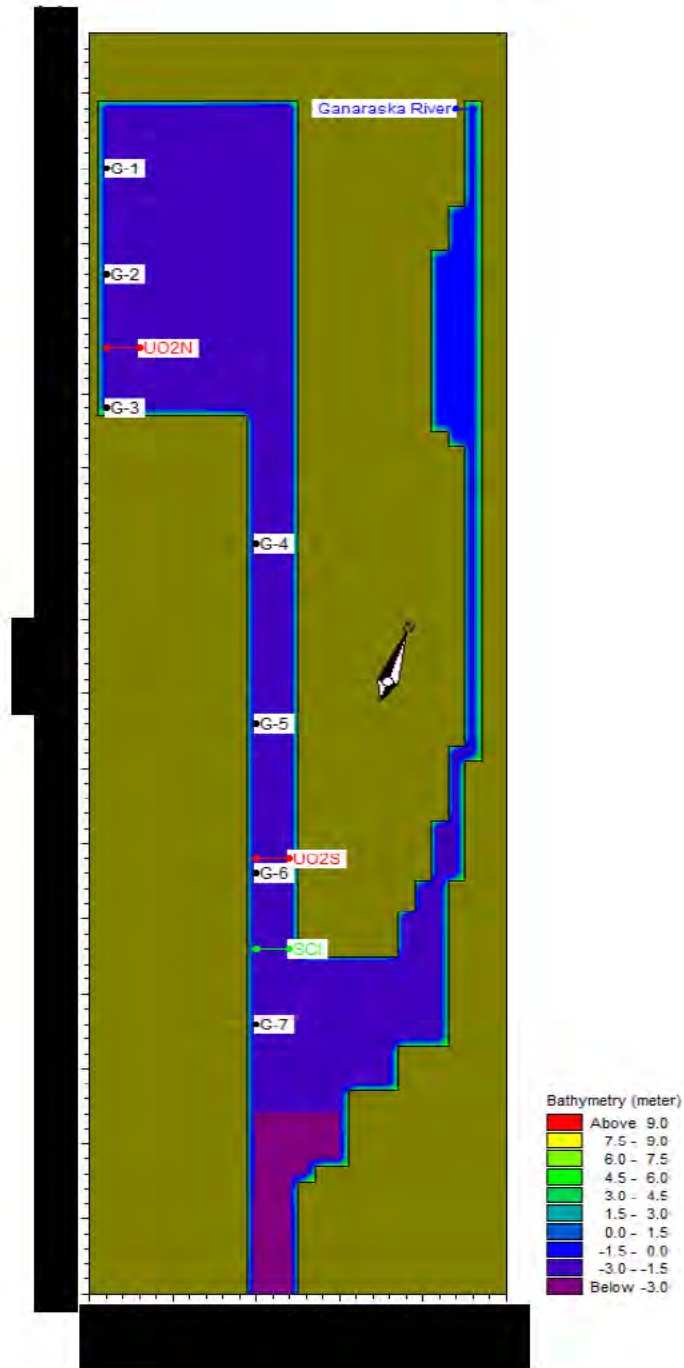

Figure 3.4. Groundwater Discharge Areas in Model



### 3.3.1.2 Stormwater Discharges

Stormwater discharge estimates for 2010 were used from the Golder (2011) *Stormwater Control Study*, which presents flow and discharge estimates for rain events, along with overall annual estimates inferred based on precipitation records. For stormwater, loadings data are available on a per-event basis (i.e., for specific rainfall events recorded in 2010), and also on an estimated annual period. Annual loadings data were chosen for use in modelling. It is noted that storm sewer outlet #3 was sealed in 2014, and is therefore not included in the stormwater loadings in this study. Table 3.7 presents the stormwater discharge inputs used. Figure 3.5 shows the location of stormwater discharge outlets based on Golder (2011).

**Table 3.7 Stormwater Discharges and Concentrations – Averaged over the Year**

Stormwater Discharge Outlet #	Model Source Locations		Flow m <sup>3</sup> /s	Concentration					
	column	row		F (mg/L)	Ammonia (mg/L)	As (mg/L)	U (mg/L)	Ra (Bq/L)	Zn (mg/L)
2	1	73	8.69E-05	0.69	0.38	0.067	0.195	0.09	0.24
4	1	66	9.7E-05	0.69	0.38	0.067	0.195	0.09	0.24
6	1	59	2.79E-04	0.69	0.38	0.067	0.195	0.09	0.24
7	1	59	1.19E-04	0.69	0.38	0.067	0.195	0.09	0.24
8	10	54	5.29E-05	0.69	0.38	0.067	0.195	0.09	0.24
9	10	44	4.68E-05	0.69	0.38	0.067	0.195	0.09	0.24
11	10	36	1.27E-04	0.69	0.38	0.067	0.195	0.09	0.24
13	10	31	2.67E-05	0.69	0.38	0.067	0.195	0.09	0.24
15	10	25	8.58E-05	0.69	0.38	0.067	0.195	0.09	0.24

Final – Environmental Risk Assessment for the Cameco Port Hope Conversion Facility

Figure 3.5. Stormwater Discharge Outlets (Golder 2011)

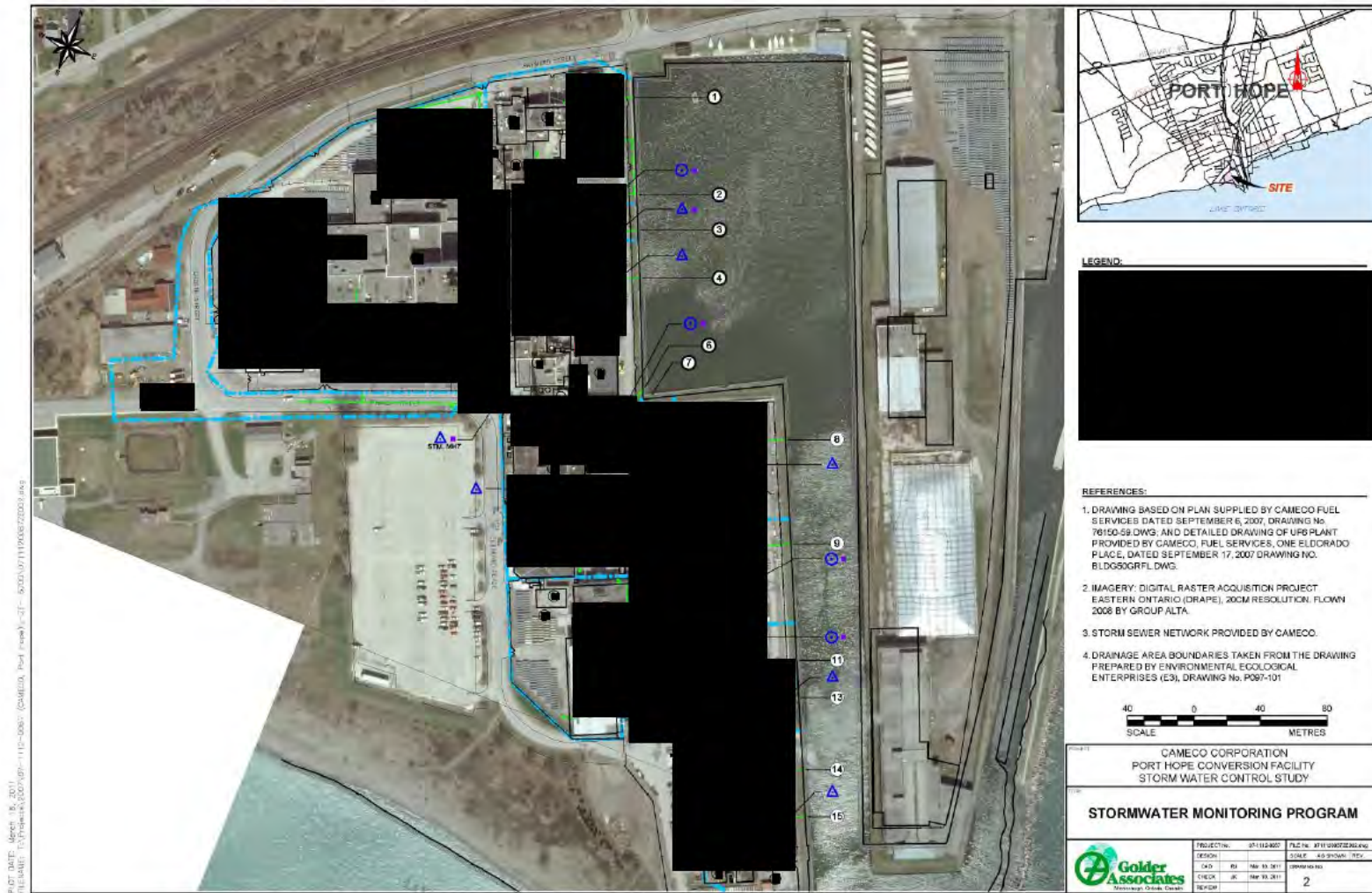
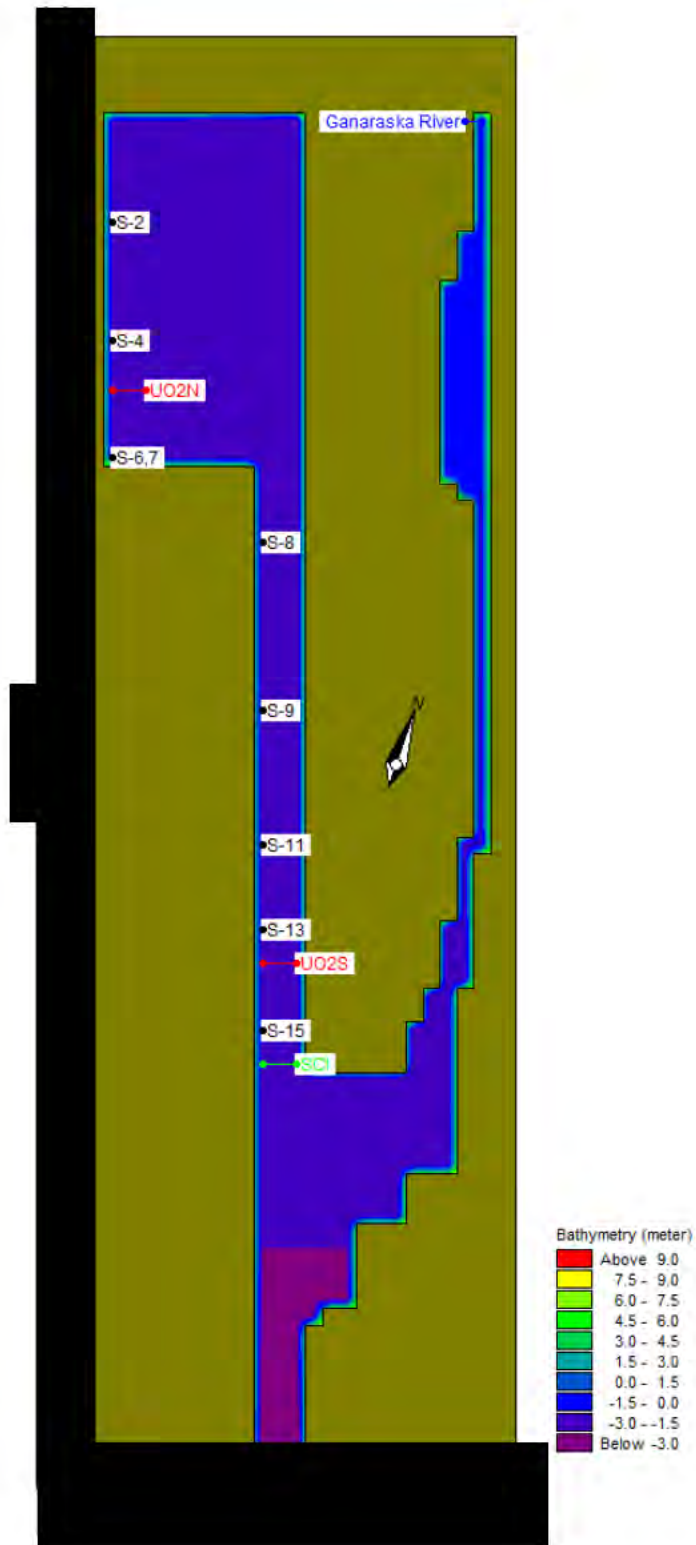

Figure 3.6. Stormwater Discharge Outlets in Model



### 3.3.2 Model Setup & Conditions

The 10 m Port Hope Harbour Model was used to simulate the plumes from the stormwater and groundwater discharges into the Harbour. The whole lake model was run to establish the harbour mouth water temperature and elevation boundary data. The simulation period was January 1, 2014 to December 28, 2014; the total time steps were 950,000.

Five scenarios were simulated:

- Averaged groundwater;
- Averaged stormwater;
- Combined averaged groundwater and averaged stormwater;
- Dynamic stormwater; and
- Combined dynamic stormwater and averaged groundwater.

### 3.3.3 Model Station Locations

Contaminant concentrations were estimated at 10 locations within the harbour and 7 locations in the lake. Table 3.8 presents the grid reference coordinates for these locations, which are illustrated in Figure 3.7 (Harbour) and Figure 3.8 (Outside of the Harbour, within the 90 m domain).

Table 3.8 Model Estimate Locations: Grid Coordinates

Station	Grid Reference in Header
1	4, 75
2	4, 69
3	4, 61
4	10,75
5	10,69
6	10,61
7	22, 65
8	1, 63 UO <sub>2</sub> N
9	10, 23 SCI
10	10,29 UO <sub>2</sub> S
11	14,7 Harbour Mouth
12	3,10 West Site
13	23,11 East Site
14	12,7 EG1
15	13,7 EG2
16	10,10 EH1
17	17,11 EJ1

Figure 3.7. Model Estimate Locations (Harbour)

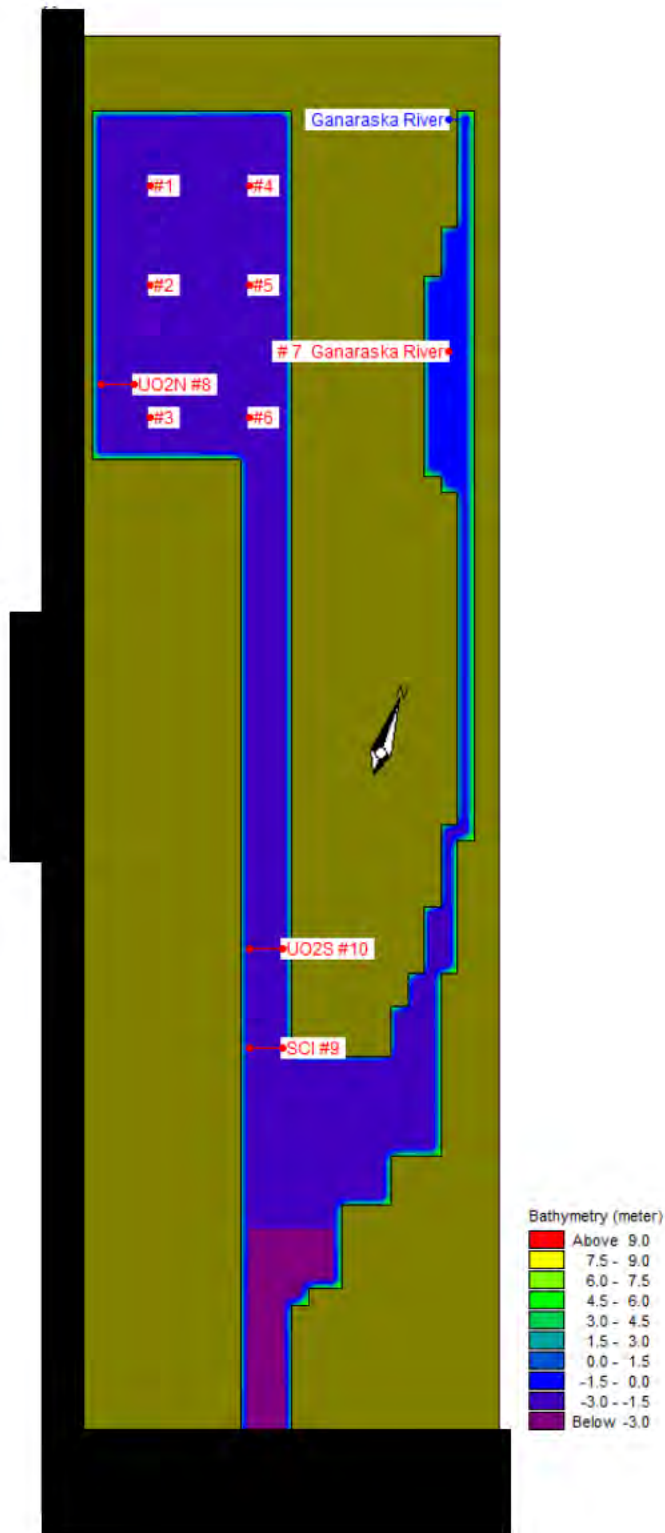
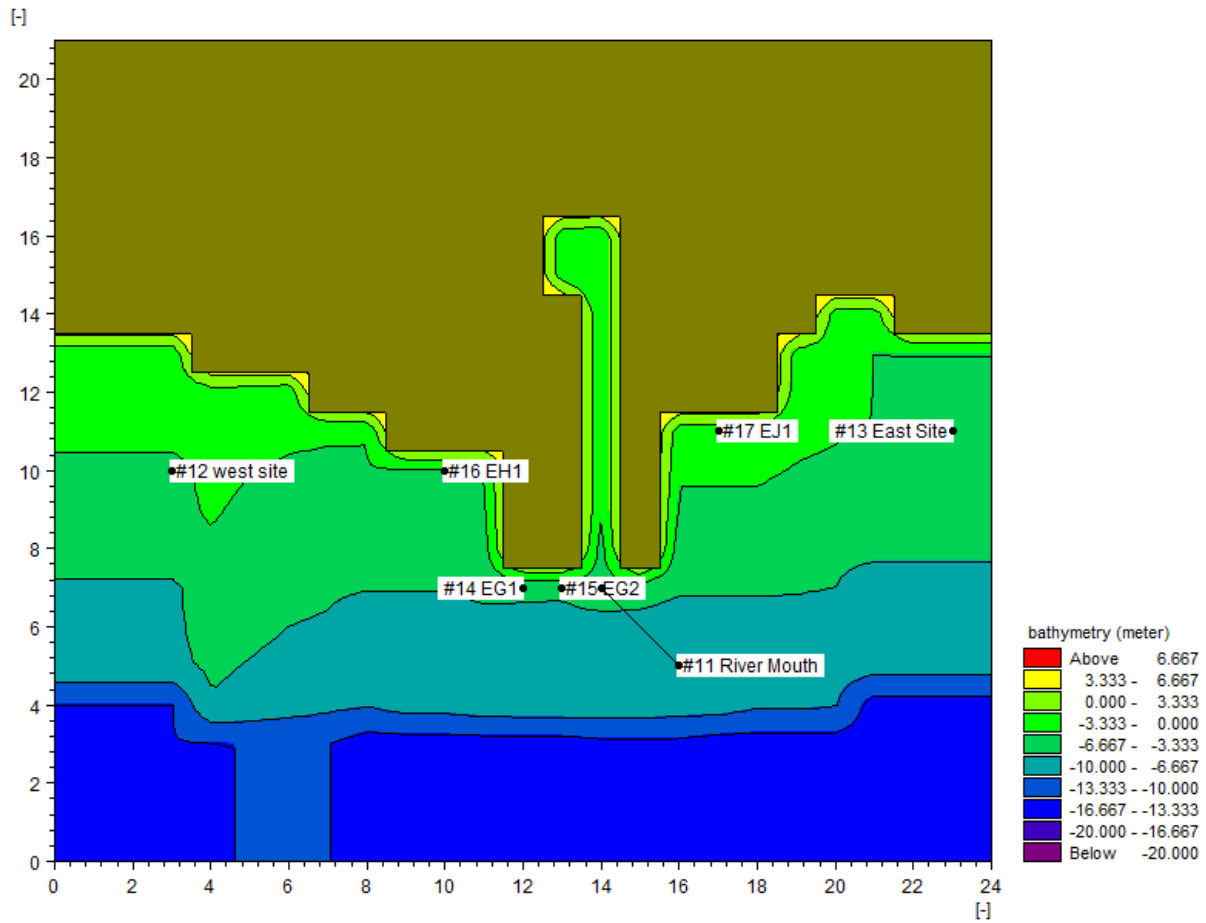



Figure 3.8. Model Estimate Locations (Lake Ontario)



### 3.3.4 Model Results and General Conclusions

As an illustration, Figure 3.9 shows an illustrative modelling result.

Final – Environmental Risk Assessment for the Cameco Port Hope Conversion Facility

Figure 3.9. Selected Model Results: Simulated Uranium Concentrations in Surface Water for the Dynamic Stormwater Plus Averaged Groundwater Scenario. Surface. Legend Indicates Station Numbers

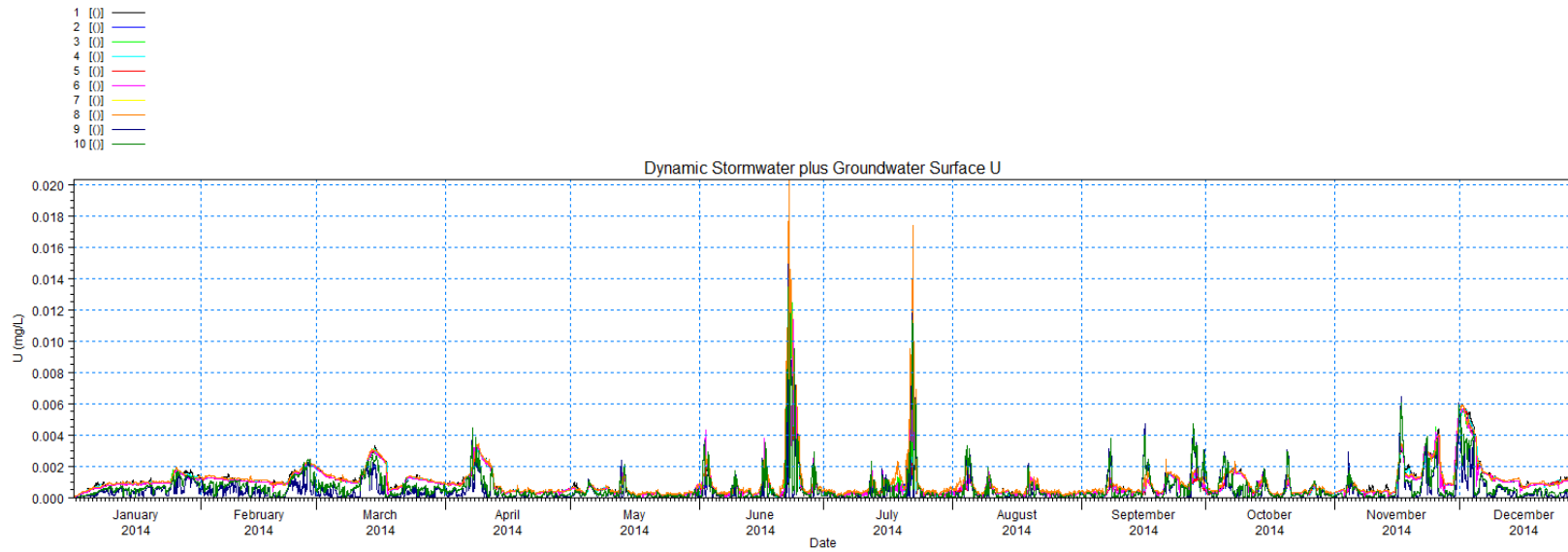

### 3.4 Gamma Modelling

MicroShield modelling was carried out to predict direct gamma radiation effective dose rates to each human receptor from each of the sources in storage areas. Each source was assumed to be half full. Specifically, the sources of gamma radiation considered in this study were uranium dioxide (UO<sub>2</sub>) in steel drums and uranium hexafluoride (UF<sub>6</sub>) in full UF<sub>6</sub> cylinders.

Specifically for gamma modelling, receptor locations were obtained from a combination of several sources, including: previous derived release limits (DRLs) reports, the 2009-2010 SWRAs, and the Vision in Motion (VIM) project. Information on the size and locations of the sources for the present study was supplied by Cameco. This information was used to create inputs for MicroShield modelling. Effective dose rates were summarized from MicroShield output files and were used to estimate both incremental effective dose rates and annual doses at the receptor locations.

Table 3.9 presents the gamma modelling results for the human receptors (discussed more in Section 5, HHRA).

Table 3.9 Gamma Modelling Results – Effective & Annual Dose Rates

Location	Receptor Type	Detail	Effective Dose Rate (µSv/h)	Annual Dose (µSv/y)
COA1	Commercial		4.05E-05	37
CODp1	Commercial		2.40E-06	2
CODp2	Commercial		6.20E-06	6
COI1	Commercial		6.89E-06	6
COI2	Commercial		1.95E-05	18
COJ1	Commercial		7.18E-06	7
COJ2	Commercial		6.78E-06	6
COWO	Commercial		3.89E-10	0
PHH23	Commercial		3.15E-05	29
Rest	Commercial		4.71E-06	4
Water Works	Commercial		1.16E-06	1
FWA1	Fenceline Walker		1.50E-04	55
FWC2	Fenceline Walker		6.22E-05	23
FWD1	Fenceline Walker		3.08E-05	11
FWD2	Fenceline Walker		2.83E-04	103
FWF1	Fenceline Walker		1.98E-05	7

Final – Environmental Risk Assessment for the Cameco Port Hope Conversion Facility

Location	Receptor Type	Detail	Effective Dose Rate ( $\mu\text{Sv/h}$ )	Annual Dose ( $\mu\text{Sv/y}$ )
FWF2	Fenceline Walker		3.53E-05	13
FWF4	Fenceline Walker		8.24E-05	30
FWG1	Fenceline Walker		2.62E-04	96
FWH1	Fenceline Walker		1.98E-04	72
FWH3	Fenceline Walker		9.04E-07	0
FWHarb	Fenceline Walker		1.02E-04	37
FWI2	Fenceline Walker		1.40E-03	511
FWJ1	Fenceline Walker		2.27E-05	8
FWJ2	Fenceline Walker		3.23E-05	12
FWJ3	Fenceline Walker		1.57E-05	6
FWJ4	Fenceline Walker		7.18E-06	3
FWJ6	Fenceline Walker		4.44E-05	16
FWJ8	Fenceline Walker		6.10E-03	2227
FWNew8	Fenceline Walker		2.49E-04	91
FWRW	Fenceline Walker		7.10E-06	3
TLD10	Fenceline Walker		5.90E-05	22
TLD17	Fenceline Walker		5.86E-06	2
TLD31	Fenceline Walker		3.10E-04	113
TLD32	Fenceline Walker		4.25E-06	2
TLD5	Fenceline Walker		3.41E-04	124
TLD6	Fenceline Walker		8.92E-05	33
TLD7	Fenceline Walker		9.18E-07	0
TLD8	Fenceline Walker		5.15E-03	1881
TLD9	Fenceline Walker		2.04E-04	74
boardwalk	Recreational	Beach	2.00E-06	0
Centre Pier	Recreational	Park/Trail	1.19E-04	43
ED6	Recreational	Fishing	7.24E-05	93
EF1	Recreational	Fishing	2.54E-05	32
EF2	Recreational	Fishing	3.65E-05	47

Final – Environmental Risk Assessment for the Cameco Port Hope Conversion Facility

Location	Receptor Type	Detail	Effective Dose Rate ( $\mu\text{Sv/h}$ )	Annual Dose ( $\mu\text{Sv/y}$ )
EF3	Recreational	Fishing	5.96E-05	76
EJ3	Recreational	Fishing	3.20E-05	41
RCEDp1	Recreational	Camping	2.31E-05	3
RFED2	Recreational	Fishing	2.70E-04	345
RFEDp1	Recreational	Fishing	3.75E-06	5
RFJ2	Recreational	Fishing	6.26E-06	8
RSJ1	Recreational	Beach	4.25E-06	1
Trail2	Recreational	Park/Trail	2.28E-06	1
RMV2	Recreational	Yacht Club	6.26E-06	8
RYED1	Recreational	Yacht Club	3.72E-06	5
RYED3	Recreational	Yacht Club	7.22E-07	1
RYED4	Recreational	Yacht Club	2.22E-05	28
RYED5	Recreational	Yacht Club	1.22E-05	16
RYEX3	Recreational	Yacht Club	8.12E-05	104
RYEX4	Recreational	Yacht Club	3.32E-05	42
PHH14	Residential		3.28E-06	18
PHR11	Residential		4.76E-06	26
PHR12	Residential		2.00E-06	11
REAH	Residential		3.10E-06	17
REAP	Residential		9.27E-06	52
REAS	Residential		5.26E-06	29
REMM	Residential		4.34E-06	24
CK1	Commercial		8.36E-05	87
CK2	Commercial		1.38E-05	14
TLD23	Fenceline Walker		9.18E-05	34
TLD20	Fenceline Walker		0.000438	160
TLD21	Fenceline Walker		8.6E-05	31
TLD18	Fenceline Walker		0.000223	81
TLD19	Fenceline Walker		2.63E-05	10

Location	Receptor Type	Detail	Effective Dose Rate ( $\mu\text{Sv/h}$ )	Annual Dose ( $\mu\text{Sv/y}$ )
TLD22	Fenceline Walker		9.42E-05	34
EK1	Recreational	Park/Trail	2E-06	1
RK3	Residential		2.99E-05	166
RK2	Residential		1.64E-05	91
RK5	Residential		8.35E-06	46
RK1	Residential		1.13E-05	63
RK4	Residential		2.24E-06	12

### 3.4.1 Potential Neutron Dose:

In 2009, SENES conducted an assessment of neutron dose rates from  $\text{UF}_6$  cylinders at the PHCF.

As discussed in the SENES (2009) study, the potential dose to workers and members of the public from neutron radiation has been investigated in the past by both Cameco and the CNSC. Cameco has also carried out a neutron survey at PHCF in 2000 which concluded that no special restrictions or monitoring of workers were warranted, including when working close to  $\text{UF}_6$  cylinders.

The CNSC has commented on various environmental matters related to the PHCF, and in their comments, have considered the possible neutron doses at the PHCF. The CNSC noted that the emission of neutrons from a  $\text{UF}_6$  cylinder is a well understood phenomenon and that neutron radiation fields produced in this way are measurable but small relative to the gamma fields emitted by the cylinder. In summary, the CNSC has concluded that the neutron dose rate from  $\text{UF}_6$  cylinders is very low and separate monitoring of neutron radiation levels is not warranted.

Neutron dose surveys conducted at the time of the SENES (2009) study - using Landauer's passive CR-39 monitors placed around the PHCF and other sites in and around Port Hope - showed quite low neutron dose rates *below Landauer's instrument limit of detection*. However, by comparing the *raw* Landauer data from fenceline monitoring locations to the *raw* data from other distant monitoring locations (i.e. those unaffected by the PHCF), an incremental fenceline neutron dose rate was calculated to be about  $0.008 \mu\text{Sv/h}$ .

The neutron dose rates around  $\text{UF}_6$  cylinders were also modelled using the well-known Monte Carlo N-Particle (MCNP) model and compared with measured neutron dose rates. The measured and predicted dose rates showed a similar pattern, confirming that modelled and measured results were consistent.

Overall, the combined information from long-term monitoring using CR-39 monitors, survey data with a portable neutron meter, and modelling results, show remarkable coherence and suggest that neutron dose rates are reasonably predictable. Moreover, modelling results compare well to those reported by others. The SENES (2009) concludes that the estimated neutron dose to a receptor that is present at the fenceline for 1 hour each day is only 1% of the current Cameco licence limit for public receptors; and in addition, receptors located further away from the fenceline are exposed to much lower dose rates, and at distances beyond 70 m from the cylinders, the incremental neutron dose rates are comparable to background.

## 4 PRELIMINARY SCREENING – SELECTION OF CONTAMINANTS OF POTENTIAL CONCERN

This section contains the preliminary screening process used to identify Contaminants of Potential Concern (COPCs) that will require further evaluation in the risk assessment. The selection of COPCs was completed by comparing the maximum measured concentrations in soil, groundwater and surface water at the site to an appropriate standard.

In accordance with the MOE screening process (MOE 2005), the soil and groundwater screenings were carried out using site condition standards (SCSs) obtained from *Soil, Ground Water and Sediment Standards for Use Under Part XV.1 of the Environmental Protection Act* (MOE 2011) as the primary source. Details on the selection of appropriate standards are provided in the soil and groundwater sections below. Although not on-site, surface water data were also screened, against provincial water quality objectives (PWQOs), to identify surface water COPCs.

Many of the screening criteria (including the MOE SCSs) are based on the lowest concentration that is protective of human health or ecological species. Therefore, secondary screening steps are carried out later in this report, using additional rationale, to further distinguish between COPCs requiring evaluation as part of the human health assessment, and those requiring evaluation as part of the ecological assessment.

In general, the preliminary screening identified COPCs (those carried forward for further evaluation) if the analyte satisfied one of the following conditions:

1. The maximum concentration exceeded the corresponding screening criterion; or
2. In the absence of a screening criterion, the maximum concentration exceeded the expected range of background concentrations; or
3. The analyte is present in measurable concentrations, and screening criteria are not available, but toxicity benchmarks are available; or
4. In some cases: if the analyte was identified as a COPC in other relevant connected environmental media (i.e., at levels exceeding screening criteria in those connected media) and is of interest e.g., due to the findings of previous studies.

If an analyte is present in measurable concentrations, but there is no screening criterion, and there is no toxicity data, then the analyte was not considered for further assessment, as this is precluded by a lack the toxicity data.

If an analyte does not have a corresponding screening criterion, but also has non-detect levels in media, then it was not considered for further evaluation, unless it was identified as a COPC in relevant connected media. In other words, if an analyte was measured at non-detect levels in a medium but has no corresponding criterion, then it is excluded, unless the same analyte was also detected in measurable levels in other media that may result in a transfer. In such circumstances, a decision is made on a case-by-case basis due to the complexity of the site and the interaction of the different environmental media.

It is important to note however, that variations to the general procedure above may exist for select contaminants and environmental media.

Groundwater:

Groundwater screening follows the overall screening procedure outlined above. The results of groundwater screening are shown below in their respective sub-section. Those analytes that exceed their corresponding criteria are identified as COPCs and undergo further secondary screening for HHRA (see Section 5.1.2) and EcoRA (see Section 6.1.3).

**Groundwater:** *measured concentrations in on-site groundwater are compared to screening criteria. Analytes that exceed their corresponding criteria are identified as COPCs and undergo further secondary screening.*

Soil:

Soil screening follows the overall screening procedure outlined above using on-site and off-site-grass-strip soil data. The results of soil screening are shown below in their respective sub-section. Those analytes that exceed their corresponding criteria are identified as COPCs and undergo further secondary screening for HHRA (see Section 5.1.2) and EcoRA (see Section 6.1.3).

**Soil:** *maximum measured concentrations in soil are compared to screening criteria. Analytes that exceed their corresponding criteria are identified as COPCs and undergo further secondary screening.*

Surface Water:

Surface water screening follows the overall screening procedure outlined above, where maximum measured surface water concentrations are compared to their corresponding screening criteria. Analytes that exceed their corresponding criteria are identified as COPCs.

**Surface Water:** *maximum measured concentrations from the harbor are compared to screening criteria. Analytes that exceed their corresponding criteria are identified as COPCs.*

## 4.1 Groundwater – Preliminary Screening

Preliminary screening of groundwater data is presented in Table 4.1. Maximum measured concentrations were compared to the following groundwater screening criteria:

- MOE (2011) *Soil, Groundwater and Sediment Standards* (Table 9 values).

The MOE (2011) Table 9 values (for use within 30 m of a water body) were chosen since portions of the site are within 30 m of Lake Ontario or specifically the Port Hope Harbour (channel and turning basin), and on-site groundwater has the potential to reach these water bodies.



Table 4.1 Groundwater: Preliminary Screening

Parameter	Units	Screening Criteria (MOE 2011)	Max. GW Value	Evaluate as COPC?	Comments
pH	units	NA	9.81	No	Will influence toxicity but not a COPC
Cond.	uS/cm	N/A	149000	No	Will influence toxicity but not a COPC
Alkalinity	mg/L CaCO <sub>3</sub>	N/A	2760	No	Will influence toxicity but not a COPC
Carbonate	mg/L CaCO <sub>3</sub>	N/A	50	No	Will influence toxicity but not a COPC
HCO <sub>3</sub>	mg/L CaCO <sub>3</sub>	N/A	2760	No	Will influence toxicity but not a COPC
OH	mg/L CaCO <sub>3</sub>	N/A	7	No	Will influence toxicity but not a COPC
Fluoride	mg/L	NA	75	Yes	Measurable levels in groundwater; no screening criterion.
TDS	mg/L	N/A	158000	Yes	Measurable levels in groundwater; no screening criterion. Exceeds typical levels of TDS in groundwater of <5000 mg/L (WHO 1996) and 3010 mg/L (MOE 2011).
Sulphate	mg/L	N/A	1200	Yes	Measurable levels in groundwater; no screening criterion. Concentration exceeds typical levels in groundwater of 1 to 1000 mg/L (WHO 1996) and 1070 mg/L (MOE 2011).
Chloride	µg/L	1.8E+06	8.2E+07	Yes	Exceeds screening criterion.
Nitrite	as N mg/L	N/A	<0.3	No	Below detection limit; no screening criterion.
Nitrate	as N mg/L	N/A	115	Yes	Measurable levels in groundwater; no screening criterion. Exceeds typical levels of nitrate in groundwater of 0.01 to 10 mg/L (WHO 1996).
Ammonia (Total)	as N mg/L	NA	150	Yes	Measurable levels in groundwater; no screening criterion. Concentration exceeds typical levels in groundwater of 3.95 mg/L (MOE 2011)
Tot.Reactive P	mg/L	N/A	4.65	No	Measurable levels in groundwater; no screening criterion; toxicity data not available.
DOC	mg/L	N/A	96.8	No	Will influence toxicity but not a COPC.
TOC	mg/L	N/A	16.3	No	Will influence toxicity but not a COPC.
Hardness	mg/L CaCO <sub>3</sub>	N/A	51700	No	Will influence toxicity but not a COPC.
Ag	µg/L	1.2	30	Yes	Exceeds screening criterion.

Final – Environmental Risk Assessment for the Cameco Port Hope Conversion Facility

Parameter	Units	Screening Criteria (MOE 2011)	Max. GW Value	Evaluate as COPC?	Comments
Al	µg/L	NA	220	Yes	Measurable levels in groundwater; no screening criterion. Concentration exceeds typical levels in groundwater of 86.9 mg/L (MOE 2011) and is within typical levels in groundwater of between 10 and 10,000 µg/L (WHO 1996).
As	µg/L	1500	1150	Yes	Less than screening criterion; however, has been included for further evaluation due to its identification as a COPC (i) in other media; and (ii) in previous studies.
Ba	µg/L	23000	6540	No	Less than screening criterion.
Be	µg/L	53	<0.007	No	Non-detect levels; MDL does not exceed screening criterion.
B (total)	µg/L	36000	1470	No	Less than screening criterion.
Bi	µg/L	NA	<0.007	No	Non-detect levels; no screening criterion.
Ca	µg/L	NA	12200000	Yes	Measurable levels in groundwater; no screening criterion. Exceeds typical levels in groundwater of between 1 and 1000 mg/L (WHO 1996) and 431 mg/L (MOE 2011).
Cd	µg/L	2.1	<0.003	No	Non-detect levels; MDL does not exceed screening criterion.
Co	µg/L	52	20	No	Less than screening criterion.
Cr	µg/L	640	20	No	Less than screening criterion.
Cu	µg/L	69	290	Yes	Exceeds screening criterion.
Fe	µg/L	NA	36700	Yes	Measurable levels in groundwater; no screening criterion. Exceeds typical levels in groundwater of 0.01 to 10 mg/L (WHO 1996) and 4090 mg/L (MOE 2011).
K	µg/L	NA	1080000	Yes	Measurable levels in groundwater; no screening criterion. Exceeds typical levels in groundwater of 20700 µg/L (MOE 201).
Mg	µg/L	NA	5190000	Yes	Measurable levels in groundwater; no screening criterion. Exceeds typical levels in groundwater of between 1 and 1000 mg/L (WHO 1996) and 134 mg/L (MOE 2011).
Mn	µg/L	NA	2600	Yes	Measurable levels in groundwater; no screening criterion. Exceeds typical levels in groundwater of 0.1 to 100 µg/L (WHO 1996) and 717 µg/L (MOE 2011).
Mo	µg/L	7300	230	No	Less than screening criterion.

Final – Environmental Risk Assessment for the Cameco Port Hope Conversion Facility

Parameter	Units	Screening Criteria (MOE 2011)	Max. GW Value	Evaluate as COPC?	Comments
Na	µg/L	1.8E+06	23700000	Yes	Exceeds screening criterion. Exceeds typical levels in groundwater of between 1 and 1000 mg/L (WHO 1996) and 489 mg/L (MOE 2011).
Ni	µg/L	390	100	No	Less than screening criterion.
P	µg/L	NA	3260	No	Measurable levels in groundwater; no screening criterion. Below typical levels in groundwater of 7.97 mg/L (MOE 2011).
Pb	µg/L	20	20	No	Does not exceed screening criterion.
Sb	µg/L	16000	30	No	Less than screening criterion.
Se	µg/L	50	538	Yes	Exceeds screening criterion.
Si	µg/L	NA	20400	No	Measurable levels in groundwater; no screening criterion. No toxicity information available.
Sr	µg/L	NA	1090000	Yes	Measurable levels in groundwater; no screening criterion. Exceeds typical levels in groundwater of 20200 µg/L (MOE 2011).
Ti	µg/L	NA	20	No	Measurable levels in groundwater; no screening criterion. No toxicity information available.
Tl	µg/L	400	<0.005	No	Not detected; detection limit is less than screening criterion.
U	µg/L	330	21000	Yes	Exceeds screening criterion.
V	µg/L	200	20	No	Less than screening criterion.
Zn	µg/L	890	2220	Yes	Exceeds screening criterion.
Ra-226	mBq/L	NA	890	Yes	Radionuclides screened in.
F1 (C6-C10)	µg/L	420	587	Yes	Exceeds screening criterion.
F2 (C10-C16)	µg/L	150	4440	Yes	Exceeds screening criterion.
F3 (C16-C34)	µg/L	500	1720	Yes	Exceeds screening criterion.
F4 (C34-C50)	µg/L	500	1120	Yes	Exceeds screening criterion.
Benzene	µg/L	44	277	Yes	Exceeds screening criterion.
Ethy benzene	µg/L	1800	21.3	No	Less than screening criterion.
Toluene	µg/L	14000	275	No	Less than screening criterion.
Xylene (Total)	µg/L	3300	192	No	Less than screening criterion.
Bromodichloromethane	µg/L	67000	2	No	Less than screening criterion.
Bromoform	µg/L	380	1	No	Less than screening criterion.
Bromomethane	µg/L	5.6	<0.5	No	Less than screening criterion.
Carbon tetrachloride	µg/L	0.79	1.2	Yes	Exceeds screening criterion.
Chlorobenzene	µg/L	500	<0.5	No	Below detection limit. MDL is less than screening criterion.

Final – Environmental Risk Assessment for the Cameco Port Hope Conversion Facility

Parameter	Units	Screening Criteria (MOE 2011)	Max. GW Value	Evaluate as COPC?	Comments
Chloroform	µg/L	2.4	17	Yes	Exceeds screening criterion.
Dibromochloromethane	µg/L	65000	0.59	No	Less than screening criterion.
1,1-Dichloroethane	µg/L	320	31.7	No	Less than screening criterion.
1,2-Dichloroethane	µg/L	1.6	<0.5	No	Below detection limit. MDL is less than screening criterion.
1,1-Dichloroethylene	µg/L	1.6	20.8	Yes	Exceeds screening criterion.
cis-1,2-Dichloroethene	µg/L	1.6	1020	Yes	Exceeds screening criterion.
trans-1,2-Dichloroethene	µg/L	1.6	28.6	Yes	Exceeds screening criterion.
1,2-Dichloropropane	µg/L	16	<0.5	No	Below detection limit. MDL is less than screening criterion.
cis-1,3-Dichloropropene	µg/L	5.2	<0.5	No	Below detection limit. MDL is less than screening criterion.
trans-1,3-Dichloropropene	µg/L		<0.5	No	Below detection limit. MDL is less than screening criterion.
Ethylenedibromide	µg/L	0.25	<1	Yes	Below detection limit. MDL exceeds screening criterion.
Dichloromethane	µg/L	610	2	No	Less than screening criterion.
1,1,1,2-Tetrachloroethane	µg/L	3.3	<0.5	No	Below detection limit. MDL is less than screening criterion.
1,1,2,2-Tetrachloroethane	µg/L	3.2	0.25	No	Less than screening criterion.
Tetrachloroethylene (perchloroethylene)	µg/L	1.6	1.4	No	Less than screening criterion.
1,2,4-Trichlorobenzene	µg/L	180	0.25	No	Less than screening criterion.
1,1,1-Trichloroethane	µg/L	640	15.1	No	Less than screening criterion.
1,1,2-Trichloroethane	µg/L	4.7	<1.2	No	Below detection limit. MDL is less than screening criterion.
Trichloroethylene	µg/L	1.6	1800	Yes	Exceeds screening criterion.
Vinyl Chloride	µg/L	0.5	613	Yes	Exceeds screening criterion.
1,2-Dichlorobenzene	µg/L	4600	<0.5	No	Below detection limit. MDL is less than screening criterion.
1,3-Dichlorobenzene	µg/L	7600	<0.5	No	Below detection limit. MDL is less than screening criterion.
1,4-Dichlorobenzene	µg/L	8	0.6	No	Less than screening criterion.

Final – Environmental Risk Assessment for the Cameco Port Hope Conversion Facility

Parameter	Units	Screening Criteria (MOE 2011)	Max. GW Value	Evaluate as COPC?	Comments
Trichlorofluoromethane	µg/L	2000	<5	No	Below detection limit. MDL is less than screening criterion.
Dichlorodifluoromethane	µg/L	3500	2.3	No	Less than screening criterion.
PCBs	µg/L	0.2	<0.02	No	Below detection limit. MDL is less than screening criterion.

Notes:

MOE (2011) *Soil, Groundwater and Sediment Standards*, Table 9: Standards for Use within 30 m of a Water Body, and Table 8.4: Summary of PGMIS Data for Background Groundwater Concentrations.

NA – Not Available.

N/A – Not Applicable.

Based on the preliminary screening in Table 4.1, the following groundwater COPCs were identified; these COPCs will undergo secondary screening as part of the HHRA (see Section 5.1.2) and EcoRA (see Section 6.1.3):

- |                    |                  |  |
|--------------------|------------------|--|
| 1. Fluoride        | 13. K            | 25. Benzene                                    |
| 2. TDS             | 14. Mg           | 26. Carbon tetrachloride                       |
| 3. Sulphate        | 15. Mn           | 27. Chloroform                                 |
| 4. Chloride        | 16. Na           | 28. 1,1-Dichloroethylene (vinylidene chloride) |
| 5. Nitrate         | 17. Se           | 29. cis-1,2-Dichloroethene                     |
| 6. Ammonia (Total) | 18. Sr           | 30. trans-1,2-Dichloroethene                   |
| 7. Ag              | 19. U            | 31. Ethylenedibromide                          |
| 8. Al              | 20. Zn           | 32. Trichloroethylene                          |
| 9. As              | 21. F1 (C6-C10)  | 33. Vinyl Chloride                             |
| 10. Ca             | 22. F2 (C10-C16) | 34. Radionuclides                              |
| 11. Cu             | 23. F3 (C16-C34) |  |
| 12. Fe             | 24. F4 (C34-C50) |  |

Note: all radionuclides are screened into the HHRA and EcoRA calculations.

## 4.2 Soil – Preliminary Screening

Preliminary screening of soil data is presented in Table 4.2. Maximum measured concentrations from all soil depths were compared to the following soil screening criteria:

- MOE (2011) *Soil, Groundwater and Sediment Standards* (Table 3a values); and

For soil criteria, MOE (2011) Table 3 *Full Depth Generic Site Condition Standards in a Non-Potable Ground Water Condition* was used. Within the MOE (2011) Table 3 standards, criteria for *Industrial/Commercial/Community Property Use* and *Course Soils* were used. Although portions of the PHCF property are within 30 m of the Port Hope Harbour (Lake Ontario), the corresponding MOE (2011) Table 9 values for use within 30 m of a water body were *not* chosen as the most appropriate standard. According to MOE (2011), the Table 9 standards were derived with the objective of protecting surface water bodies from movement of soil directly into surface water to become sediment, and assuming there is no dilution in the groundwater for the aquatic protection pathway. As the PHCF site borders a harbour with a concrete wall separating soil from sediment, soil cannot flow into the harbour in significant quantities and therefore the use of Table 3 criteria was more appropriate in this location.

If for a given analyte, a screening criterion (i.e., a SCS) was not provided in MOE (2011), maximum measured concentrations were compared to the CCME (2014) *Soil Quality Guidelines for the Protection of Environmental and Human Health*. This occurred for only one contaminant: fluoride.

Table 4.2 Soil: Preliminary Screening

Parameter	Units	Screening Criteria	Toxicity Data Avail.?	Max. Soil Level	Evaluate as COPC?	Comments
		MOE (2011) Table 3a Standard <sup>1</sup>				
Moisture	%	NA	N	99.2	No	Measurable levels in soil; no screening criterion available; no toxicity data available.
Fluoride	µg/g	NA	Y	20400	Yes	Measurable levels in soil; no MOE screening criterion available; exceeds CCME soil quality guideline of 2000 µg/g; toxicity data available.
Nitrate	µg/g	NA	Y	1500	Yes	Measurable levels in soil; no screening criterion available; toxicity data available.
Nitrite	µg/g	NA	Y	11	Yes	Measurable levels in soil; no screening criterion available; toxicity data available.
Ammonia (Total)	µg/g	NA	Y	2190	Yes	Measurable levels in soil; no screening criterion available; toxicity data available.
Bromide	µg/g	NA	Y	490	Yes	Measurable levels in soil; no screening criterion available; toxicity data available.
Chloride	µg/g	NA	Y	696	Yes	Measurable levels in soil; no screening criterion available; toxicity data available.
Phosphate	µg/g	NA	Y	862	Yes	Measurable levels in soil; no screening criterion available; toxicity data available.
Sulphate	µg/g	NA	Y	15100	Yes	Measurable levels in soil; no screening criterion available; toxicity data available.
Ag	µg/g	40	Y	40	No	Does not exceed screening criterion.
Al	µg/g	NA	Y	36300	Yes	Measurable levels in soil; no screening criterion available; toxicity data available.
As	µg/g	18	Y	1790	Yes	Exceeds screening criterion; toxicity data available.
Ba	µg/g	670	Y	2020	Yes	Exceeds screening criterion; toxicity data available.
Be	µg/g	8	Y	1.6	No	Less than screening criterion.



Final – Environmental Risk Assessment for the Cameco Port Hope Conversion Facility

Parameter	Units	Screening Criteria MOE (2011) Table 3a Standard <sup>1</sup>	Toxicity Data Avail.?	Max. Soil Level	Evaluate as COPC?	Comments
Bi	µg/g	NA	N	55	No	Measurable levels in soil; no screening criterion available; no toxicity data available.
B (total)	µg/g	120	Y	1790	Yes	Exceeds screening criterion; toxicity data available.
Ca	µg/g	NA	N	316000	No	Measurable levels in soil; no screening criterion available; no toxicity data available.
Cd	µg/g	1.9	Y	9.8	Yes	Exceeds screening criterion.
Co	µg/g	80	Y	2730	Yes	Exceeds screening criterion.
Cr	µg/g	160	Y	114	No	Less than screening criterion.
Cu	µg/g	230	Y	8830	Yes	Exceeds screening criterion.
Fe	µg/g	NA	Y	180000	Yes	Measurable levels in soil; no screening criterion available; toxicity data available.
K	µg/g	NA	Y	45000	Yes	Measurable levels in soil; no screening criterion available; toxicity data available.
Mg	µg/g	NA	Y	84300	Yes	Measurable levels in soil; no screening criterion available; toxicity data available.
Mn	µg/g	NA	Y	3600	Yes	Measurable levels in soil; no screening criterion available; toxicity data available.
Mo	µg/g	40	Y	15	No	Less than screening criterion.
Na	µg/g	NA	N	10000	No	Measurable levels in soil; no screening criterion available; no toxicity data available.
Ni	µg/g	270	Y	5690	Yes	Exceeds screening criterion.
Pb	µg/g	120	Y	30000	Yes	Exceeds screening criterion.
P	µg/g	NA	N	44900	No	Measurable levels in soil; no screening criterion available; no toxicity data available.
Se	µg/g	5.5	Y	16	Yes	Exceeds screening criterion.
Sb	µg/g	40	Y	166	Yes	Exceeds screening criterion.

Final – Environmental Risk Assessment for the Cameco Port Hope Conversion Facility

Parameter	Units	Screening Criteria MOE (2011) Table 3a Standard <sup>1</sup>	Toxicity Data Avail.?	Max. Soil Level	Evaluate as COPC?	Comments
Si	µg/g	NA	N	5800	No	Measurable levels in soil; no screening criterion available; no toxicity data available.
Sr	µg/g	NA	Y	3000	Yes	Measurable levels in soil; no screening criterion available; toxicity data available.
Ti	µg/g	NA	N	2100	No	Measurable levels in soil; no screening criterion available; no toxicity data available.
Tl	µg/g	3.3	Y	0.94	No	Less than screening criterion.
U	µg/g	33	Y	16800	Yes	Exceeds screening criterion.
V	µg/g	86	Y	150	Yes	Exceeds screening criterion.
Zn	µg/g	340	Y	5500	Yes	Exceeds screening criterion.
Ra-226	Bq/g	NA	Y	32	Yes	All radionuclides included.
Benzene	µg/g	0.32	Y	<0.002	No	Non-detect levels; MDL less than screening criterion.
Ethy benzene	µg/g	9.5	Y	0.012	No	Less than screening criterion.
Toluene	µg/g	68	Y	0.028	No	Less than screening criterion.
Xylene (total)	µg/g	26	Y	0.212	No	Less than screening criterion.
Bromodichloromethane	µg/g	18	Y	<0.002	No	Non-detect levels; MDL less than screening criterion.
Bromoform	µg/g	0.61	Y	<0.002	No	Non-detect levels; MDL less than screening criterion.
Bromomethane	µg/g	0.05	Y	<0.009	No	Non-detect levels; MDL less than screening criterion.
Carbon tetrachloride	µg/g	0.21	Y	<0.002	No	Non-detect levels; MDL less than screening criterion.
Chlorobenzene	µg/g	2.4	Y	<0.002	No	Non-detect levels; MDL less than screening criterion.
Chloroform	µg/g	0.47	Y	<0.003	No	Non-detect levels; MDL less than screening criterion.
Dibromochloromethane	µg/g	13	Y	<0.002	No	Non-detect levels; MDL less than screening criterion.
1,1-Dichloroethane	µg/g	17	Y	<0.002	No	Non-detect levels; MDL less than screening criterion.
1,2-Dichloroethane	µg/g	0.05	Y	<0.002	No	Non-detect levels; MDL less than screening criterion.

Final – Environmental Risk Assessment for the Cameco Port Hope Conversion Facility

Parameter	Units	Screening Criteria MOE (2011) Table 3a Standard <sup>1</sup>	Toxicity Data Avail.?	Max. Soil Level	Evaluate as COPC?	Comments
1,1-Dichloroethylene	µg/g	0.064	Y	<0.002	No	Non-detect levels; MDL less than screening criterion.
cis-1,2-Dichloroethylene	µg/g	55	Y	0.003	No	Less than screening criterion.
trans-1,2-Dichloroethylene	µg/g	1.3	Y	<0.004	No	Non-detect levels; MDL less than screening criterion.
1,2-Dichloropropane	µg/g	0.16	Y	<0.002	No	Non-detect levels; MDL less than screening criterion.
cis-1,3-dichloropropene	µg/g	0.18	Y	<0.002	No	Non-detect levels; MDL less than screening criterion.
trans-1,3-dichloropropene	µg/g	0.18	Y	<0.002	No	Non-detect levels; MDL less than screening criterion.
Ethylenedibromide	µg/g	0.05	Y	<0.002	No	Non-detect levels; MDL less than screening criterion.
Dichloromethane	µg/g	1.6	Y	0.021	No	Less than screening criterion.
Tetrachloroethane, 1,1,1,2-	µg/g	0.087	Y	<0.002	No	Non-detect levels; MDL less than screening criterion.
Tetrachloroethane, 1,1,2,2-	µg/g	0.05	Y	<0.004	No	Non-detect levels; MDL less than screening criterion.
Tetrachloroethylene	µg/g	4.5	Y	<0.002	No	Non-detect levels; MDL less than screening criterion.
1,2,4-Trichlorobenzene	µg/g	3.2	Y	0.004	No	Less than screening criterion.
1,1,1-Trichloroethane	µg/g	6.1	Y	<0.003	No	Non-detect levels; MDL less than screening criterion.
1,1,2-Trichloroethane	µg/g	0.05	Y	<0.002	No	Non-detect levels; MDL less than screening criterion.
Trichloroethylene	µg/g	0.91	Y	0.188	No	Less than screening criterion.
Vinyl Chloride	µg/g	0.032	Y	<0.003	No	Non-detect levels; MDL less than screening criterion.
1,2-Dichlorobenzene	µg/g	6.8	Y	<0.002	No	Non-detect levels; MDL less than screening criterion.
1,3-Dichlorobenzene	µg/g	9.6	Y	0.005	No	Less than screening criterion.
1,4-Dichlorobenzene	µg/g	0.2	Y	0.002	No	Less than screening criterion.
Trichlorofluoromethane	µg/g	4	Y	<0.002	No	Non-detect levels; MDL less than screening criterion.
Dichlorodifluoromethane	µg/g	16	Y	<0.002	No	Non-detect levels; MDL less than screening criterion.

Final – Environmental Risk Assessment for the Cameco Port Hope Conversion Facility

Parameter	Units	Screening Criteria MOE (2011) Table 3a Standard <sup>1</sup>	Toxicity Data Avail.?	Max. Soil Level	Evaluate as COPC?	Comments
F1 (C6-C10)	µg/g	55	Y	245	Yes	Exceeds screening criterion.
F2 (C10-C16)	µg/g	230	Y	3200	Yes	Exceeds screening criterion.
F3 (C16-C34)	µg/g	1700	Y	140000	Yes	Exceeds screening criterion.
F4 (C34-C50)	µg/g	3300	Y	1700	No	Less than screening criterion.
PCBs (Total)	µg/g	1.1	Y	12	Yes	Exceeds screening criterion.

Notes:

<sup>1</sup> MOE (2011) Table 3a - Full Depth Generic Site Condition Standards in a Non-Potable Ground Water Condition.

NA - Not Available.

NV - "No Value" designation according to MOE (2011).

Based on the preliminary screening in Table 4.2, the following soil COPCs were identified; these COPCs will undergo further secondary screening as part of the HHRA (see Section 5.1.2) and EcoRA (see Section 6.1.3):

- |                    |        |                   |
|--------------------|--------|-------------------|
| 1. Fluoride        | 13. Cd | 25. U             |
| 2. Nitrate         | 14. Co | 26. V             |
| 3. Nitrite         | 15. Cu | 27. Zn            |
| 4. Ammonia (total) | 16. Fe | 28. F1 (C6-C10)   |
| 5. Bromide         | 17. K  | 29. F2 (C10-C16)  |
| 6. Chloride        | 18. Mg | 30. F3 (C16-C34)  |
| 7. Phosphate       | 19. Mn | 31. PCBs (total)  |
| 8. Sulphate        | 20. Ni | 32. Radionuclides |
| 9. Al              | 21. Pb |                   |
| 10. As             | 22. Se |                   |
| 11. Ba             | 23. Sb |                   |
| 12. B (total)      | 24. Sr |                   |

### 4.3 Surface Water – Preliminary Screening

Preliminary screening of surface water data is presented in Table 4.3. Maximum measured concentrations were compared to the following screening criteria:

- MOE (1999) *Provincial Water Quality Objectives (PWQOs)*

If for a given analyte, a PWQO was not provided in MOE (1999), maximum measured concentrations were compared to the CCME (2014) *Water Quality Guidelines for the Protection of Aquatic Life*. If a CCME water quality guideline was not available, then the B.C. MOE (2014, online) *Ambient Water Quality Guidelines* were consulted.

Final – Environmental Risk Assessment for the Cameco Port Hope Conversion Facility

Table 4.3 Surface Water: Preliminary Screening

Parameter	Units	Surface Water Screening Criteria	Max. SW Value	Evaluate as COPC?	Comment
pH	units	6.5-8.5 <sup>1</sup>	8.36	No	Will influence toxicity but not a COPC.
Alkalinity	mg/L as CaCO <sub>3</sub>	3 <sup>1</sup>	190	No	Will influence toxicity but not a COPC.
Carbonate	mg/L as CaCO <sub>3</sub>	NA	31	No	Will influence toxicity but not a COPC.
Chloride	mg/L	120 <sup>2</sup>	130	Yes	Exceeds screening criterion.
Fluoride	µg/L	120 <sup>2</sup>	300	Yes	Exceeds screening criterion.
Conductivity	µS/cm	NA	440	No	Will influence toxicity but not a COPC.
Conductivity (calc)	µS/cm	NA	332	No	Will influence toxicity but not a COPC.
DOC	mg/L	NA	2.5	No	Will influence toxicity but not a COPC.
Hardness	mg/L as CaCO <sub>3</sub>	NA	209	No	Will influence toxicity but not a COPC.
HCO <sub>3</sub>	mg/L as CaCO <sub>3</sub>	NA	168	No	Will influence toxicity but not a COPC.
Ammonia (Total)	as N mg/L	0.197 <sup>2,11</sup>	0.5	Yes	Exceeds screening criterion.
Nitrite	as N mg/L	0.06 <sup>2</sup>	<0.06	No	Non-detect levels; detection limit does not exceed screening criterion.
Nitrate	as N mg/L	2.9 <sup>2</sup>	<2.2	No	Non-detect levels; detection limit is less than screening criterion.
OH	mg/L as CaCO <sub>3</sub>	NA	<2	No	Will influence toxicity but not a COPC. Non-detect levels; no screening criterion.
Sulphate	mg/L	309 <sup>9, 12</sup>	84	No	Less than screening criterion.
TDS	mg/L	NA	271	Yes	Measurable levels in surface water; no screening criterion available.
Tot.Reactive P	mg/L	NA	<0.03	No	Will influence toxicity but not a COPC. Non-detect levels; no screening criterion.
Ammonia (un-ionized)	µg/L	19 <sup>1</sup>	55	Yes	Exceeds screening criterion.
Ag	µg/L	0.1 <sup>1</sup>	0.06	No	Less than screening criterion.
Al	µg/L	75 <sup>1,4</sup>	150	Yes	Exceeds screening criterion.

Final – Environmental Risk Assessment for the Cameco Port Hope Conversion Facility

Parameter	Units	Surface Water Screening Criteria	Max. SW Value	Evaluate as COPC?	Comment
As	µg/L	5 <sup>1, 5, 6</sup>	3.2	Yes	Less than screening criterion; however, has been included for further evaluation due to its identification as a COPC (i) in other media; and (ii) in previous studies.
B	µg/L	200 <sup>1</sup>	45	No	Less than screening criterion.
Ba	µg/L	4 <sup>13</sup>	60	Yes	Exceeds screening criterion.
Be	µg/L	1100 <sup>1, 7</sup>	0.03	No	Less than screening criterion.
Bi	µg/L	NA	0.15	No	Measurable levels in surface water; no screening criterion available. Toxicity data not available.
Ca	mg/L	NA	65.1	No	Measurable levels in surface water; no screening criterion available. Toxicity data not available.
Cd	µg/L	0.5 <sup>1, 5, 6, 7</sup>	0.012	No	Less than screening criterion.
Co	µg/L	0.9 <sup>1</sup>	0.218	No	Less than screening criterion.
Cr	µg/L	8.9 <sup>1, 8</sup>	0.8	No	Less than screening criterion. Maximum concentration is also below the screening criterion PWQO for hexavalent chromium.
Cu	µg/L	5 <sup>1, 5, 6, 7</sup>	2.8	No	Less than screening criterion.
Fe	µg/L	300 <sup>1</sup>	280	No	Less than screening criterion.
K	mg/L	NA	5.65	Yes	Measurable levels in surface water; no screening criterion available. Toxicity data available.
Mg	mg/L	NA	11.3	No	Measurable levels in surface water; no screening criterion available. Toxicity data not available.
Mn	µg/L	800 <sup>9</sup>	43.1	No	Less than screening criterion.
Mo	µg/L	40 <sup>1</sup>	1.32	No	Less than screening criterion.
Na	mg/L	NA	13.6	No	Measurable levels in surface water; no screening criterion available. Toxicity data not available.
Ni	µg/L	25 <sup>1</sup>	1.9	No	Less than screening criterion.
P	µg/L	20 <sup>1, 5</sup>	40	Yes	Exceeds screening criterion.



Final – Environmental Risk Assessment for the Cameco Port Hope Conversion Facility

Parameter	Units	Surface Water Screening Criteria	Max. SW Value	Evaluate as COPC?	Comment
Pb	µg/L	5 <sup>1,5,6,7</sup>	1.17	No	Less than screening criterion.
Sb	µg/L	20 <sup>1,5</sup>	0.31	No	Less than screening criterion.
Se	µg/L	100 <sup>1</sup>	1	No	Less than screening criterion.
Si	mg/L	NA	3.54	No	Measurable levels in surface water; no screening criterion available. Toxicity data not available.
Sr	µg/L	NA	182	Yes	Measurable levels in surface water; no screening criterion available. Toxicity data available.
Ti	µg/L	NA	7.8	No	Measurable levels in surface water; no screening criterion available. Toxicity data not available.
Tl	µg/L	0.3 <sup>1,5</sup>	0.1	No	Less than screening criterion.
U	µg/L	5 <sup>1,5</sup>	7.8	Yes	Exceeds screening criterion.
V	µg/L	6 <sup>1,5</sup>	1.29	No	Less than screening criterion.
Zn	µg/L	20 <sup>1,5,6</sup>	8	Yes	Less than screening criterion; however, has been included for further evaluation due to its identification as a COPC (i) in other media; and (ii) in previous studies.
Ra-226	Bq/L	1 <sup>1</sup>	<0.055	Yes	All radionuclides included.
Bromodichloromethane	µg/L	200 <sup>1,5</sup>	<1	No	Non-detect levels; MDL does not exceed screening criterion.
Benzene	µg/L	100 <sup>1,5</sup>	<1	No	Non-detect levels; MDL does not exceed screening criterion.
Bromoform	µg/L	60 <sup>1,5</sup>	<1	No	Non-detect levels; MDL does not exceed screening criterion.
Bromomethane	µg/L	0.9 <sup>1,5</sup>	<0.9	No	Non-detect levels; MDL does not exceed screening criterion.
Carbon tetrachloride	µg/L	13.3 <sup>2</sup>	<0.5	No	Non-detect levels; MDL does not exceed screening criterion.
Chlorobenzene	µg/L	15 <sup>1</sup>	<5	No	Non-detect levels; MDL does not exceed screening criterion.
Chloroform	µg/L	1.8 <sup>2</sup>	<0.5	No	Non-detect levels; MDL does not exceed screening criterion.
Dibromochloromethane	µg/L	40 <sup>1,5</sup>	0.25	No	Less than screening criterion.
1,2-Dichlorobenzene	µg/L	2.5 <sup>1</sup>	<1	No	Non-detect levels; MDL does not exceed screening criterion.
1,3-Dichlorobenzene	µg/L	2.5 <sup>1</sup>	<1	No	Non-detect levels; MDL does not exceed screening criterion.

Final – Environmental Risk Assessment for the Cameco Port Hope Conversion Facility

Parameter	Units	Surface Water Screening Criteria	Max. SW Value	Evaluate as COPC?	Comment
1,4-Dichlorobenzene	µg/L	4 <sup>1</sup>	<1	No	Non-detect levels; MDL does not exceed screening criterion.
1,1-Dichloroethane	µg/L	200 <sup>1,5</sup>	<5	No	Non-detect levels; MDL does not exceed screening criterion.
1,2-Dichloroethane	µg/L	100 <sup>1,5</sup>	<5	No	Non-detect levels; MDL does not exceed screening criterion.
1,1-Dichloroethylene	µg/L	40 <sup>1,5</sup>	<0.66	No	Non-detect levels; MDL does not exceed screening criterion.
cis-1,2-Dichloroethene	µg/L	200 <sup>1,5</sup>	<5	No	Non-detect levels; MDL does not exceed screening criterion.
trans-1,2-Dichloroethene	µg/L		<5	No	Non-detect levels; MDL does not exceed screening criterion.
Dichlorodifluoromethane	µg/L	NA	2.5	Yes	Measurable levels in surface water; no screening criterion available. Toxicity data are available.
Dichloromethane	µg/L	100 <sup>1,5</sup>	2.5	No	Less than screening criterion.
1,2-Dichloropropane	µg/L	0.7 <sup>1,5</sup>	<0.7	No	Non-detect levels; MDL does not exceed screening criterion.
cis-1,3-Dichloropropene	µg/L	NA	<1	No	Non-detect levels; no screening criterion.
trans-1,3-Dichloropropene	µg/L	7 <sup>1,5</sup>	<1	No	Non-detect levels; MDL does not exceed screening criterion.
Ethylbenzene	µg/L	8 <sup>1,5</sup>	<1	No	Non-detect levels; MDL does not exceed screening criterion.
Ethylenedibromide	µg/L	5 <sup>1,5</sup>	<1	No	Non-detect levels; MDL does not exceed screening criterion.
Tetrachloroethylene (perchloroethylene)	µg/L	50 <sup>1,5</sup>	<5	No	Non-detect levels; MDL does not exceed screening criterion.
1,1,1,2-Tetrachloroethane	µg/L	20 <sup>1,5</sup>	<2	No	Non-detect levels; MDL does not exceed screening criterion.
1,1,2,2-Tetrachloroethane	µg/L	70 <sup>1,5</sup>	<1	No	Non-detect levels; MDL does not exceed screening criterion.
Toluene	µg/L	0.8 <sup>1,5</sup>	0.4	No	Less than screening criterion.
1,2,4-Trichlorobenzene	µg/L	0.5 <sup>1</sup>	<0.5	No	Non-detect levels; MDL does not exceed screening criterion.
1,1,1-Trichloroethane	µg/L	10 <sup>1,5</sup>	<5	No	Non-detect levels; MDL does not exceed screening criterion.
1,1,2-Trichloroethane	µg/L	800 <sup>1,5</sup>	<5	No	Non-detect levels; MDL does not exceed screening criterion.
Trichloroethylene	µg/L	20 <sup>1,5</sup>	<5	No	Non-detect levels; MDL does not exceed screening criterion.

Final – Environmental Risk Assessment for the Cameco Port Hope Conversion Facility

Parameter	Units	Surface Water Screening Criteria	Max. SW Value	Evaluate as COPC?	Comment
Trichlorofluoromethane	µg/L	NA	<5	No	Non-detect levels; no screening criterion.
Vinyl Chloride	µg/L	600 <sup>1, 5</sup>	<0.5	No	Non-detect levels; MDL does not exceed screening criterion.
m-p-xylene	µg/L	32 <sup>1</sup>	<0.5	No	Non-detect levels; MDL does not exceed screening criterion.
o-xylene	µg/L	40 <sup>1</sup>	<1	No	Non-detect levels; MDL does not exceed screening criterion.
Xylene (Total)	µg/L	72 <sup>1, 5, 10</sup>	<1	No	Non-detect levels; MDL does not exceed screening criterion.

Notes:

- <sup>1</sup> MOE (1999) *Provincial Water Quality Objectives*.
- <sup>2</sup> CCME (2014, online) *Water Quality Guidelines for Protection of Aquatic Life*.
- <sup>3</sup> Narrative statement that alkalinity should not be decreased by more than 25% of natural levels.
- <sup>4</sup> For pH>6.5-9, measured on a clay-free sample.
- <sup>5</sup> Interim PWQO. Interim PWQOs set for emergency purposes based on the best information readily available. Employ due caution when applying these values.
- <sup>6</sup> Both a PWQO exists, as well as an IPWQO. The IPWQO is listed as it is based on providing a greater level of aquatic protection.
- <sup>7</sup> Objective is dependent on hardness, value shown is for high hardness water based on site-specific considerations.
- <sup>8</sup> Value shown is for trivalent chromium, a value of 1 µg/L is also available for hexavalent chromium.
- <sup>9</sup> BC MOE (2014, online) screening criteria, based on most restrictive water hardness.
- <sup>10</sup> The PWQO for total xylenes was assumed to be the sum of interim PWQOs of m-Xylene (2 µg/L), p-Xylene (30 µg/L) and o-Xylene (40 µg/L).
- <sup>11</sup> Total ammonia guideline calculated based on pH of 8.5 (conservative) and temperature of 15°C (highest temperature among groundwater samples received at lab is 14°C, according to Cameco/Golder data from 2013 year - see surface water and groundwater monitoring report for 2013 monitoring year).
- <sup>12</sup> Sulphur guideline calculated based on hardness of 161 mg/L as CaCO<sub>3</sub>. Hardness measurements in harbor in 2008-2009 ranged from 161 to 209 mg/L. According to BC MOE water quality guidelines, a lower water hardness results in a lower sulphate guideline; therefore, the lowest measured hardness was used, in order to be conservative).
- <sup>13</sup> Suter and Tsao (1996), secondary chronic value. Ecological toxicity value, used in the absence of any screening criteria.

Based on the preliminary screening in Table 4.3, the following surface water COPCs were identified:

1. Chloride
2. Fluoride
3. Ammonia (Total)
4. Ammonia (un-ionized)
5. Aluminum
6. Arsenic
7. Barium
8. Phosphorus
9. Potassium
10. Strontium
11. Uranium
12. Zinc
13. Radionuclides
14. Dichlorodifluoromethane

## 4.4 Summary – Preliminary Screening

The individual COPC lists generated by preliminary screening of each environmental medium are combined and presented in Table 4.4 below. Groundwater and soil preliminary COPCs will undergo further secondary screening in their respective HHRA and EcoRA sections to determine those that will be included in human health risk calculations and those that will be included in ecological risk calculations.

In the table below, dashes indicate where measurement data are not available for a particular parameter, in a particular medium. Blanks indicate where a parameter has undergone screening and was not identified as a COPC.

It is important to note that all radionuclides identified in environmental media are considered COPCs, and will undergo further evaluation (see Table 2.1 for available radionuclide data).

Table 4.4 Summary of Preliminary Screening COPCs

Category	Parameter	Soil	Ground-water	Surface Water
Major Ions	Fluoride	Y	Y	Y
	Nitrite	Y		
	Nitrate	Y	Y	
	Ammonia (Total)	Y	Y	Y
	Ammonia (un-ionized)	-	-	Y
	Bromide	Y	-	-
	Chloride	Y	Y	Y
	Total Reactive Phosphorus	-	Y	
	Phosphate	Y	-	-
	Sulphate	Y	Y	
Physical	TDS	-	Y	
Metals	Ag		Y	
	Al	Y	Y	Y
	As	Y	Y	Y
	Ba	Y		Y
	Be			
	Bi			
	B (total)	Y		
	Ca		Y	
	Cd	Y		
	Co	Y		
	Cr			

Category	Parameter	Soil	Ground-water	Surface Water
	Cu	Y	Y	
	Fe	Y	Y	
	K	Y	Y	Y
	Mg	Y	Y	
	Mn	Y	Y	
	Mo			
	Na		Y	
	Ni	Y		
	P			Y
	Pb	Y		
	Sb	Y		
	Se	Y	Y	
	Si			
	Sr	Y	Y	Y
	Ti			
	Tl			
	U	Y	Y	Y
	V	Y		
	Zn	Y	Y	Y
<b>Rad</b>	Radionuclides (all)	Y	Y	Y
<b>VOCs &amp; BTEX</b>	Benzene		Y	
	Ethylbenzene			
	Toluene			
	Xylene (total)			
	Bromodichloromethane			
	Carbon Tetrachloride		Y	
	Chlorobenzene			
	Chloroform		Y	
	Dibromochloromethane			
	1,3-Dichlorobenzene			
	1,4-Dichlorobenzene			
	Dichlorodifluoromethane			Y
	1,1-Dichloroethylene		Y	
	cis-1,2-Dichloroethene		Y	
trans-1,2-Dichloroethene		Y		

Final – Environmental Risk Assessment for the Cameco Port Hope Conversion Facility

Category	Parameter	Soil	Ground-water	Surface Water
	Dichloromethane			
	Ethylenedibromide		Y	
	1,1,2,2-Tetrachloroethane			
	1,2,4-Trichlorobenzene			
	1,1,1-Trichloroethane			
	1,2-Dichloropropane			
	cis-1,3-Dichloropropene			
	trans-1,3-Dichloropropene			
	Trichloroethylene		Y	
	Trichlorofluoromethane			
	Vinyl Chloride		Y	
<b>PHCs</b>	F1 (C6-C10)	Y	Y	-
	F2 (C10-C16)	Y	Y	-
	F3 (C16-C34)	Y	Y	-
	F4 (C34-C50)		Y	-
<b>PCBs</b>	PCBs (Total)	Y		-

Category	Parameter	Soil	Ground-water	Surface Water
PAHs	Acenaphthene	-	-	-
	Acenaphthylene	-	-	-
	Anthracene	-	-	-
	Benzo[a] anthracene	-	-	-
	Benzo[a] pyrene	-	-	-
	Benzo[b] fluoranthene	-	-	-
	Benzo[k] fluoranthene	-	-	-
	Benzo[ghi] perylene	-	-	-
	Chrysene	-	-	-
	Dibenzo[a,h] anthracene	-	-	-
	Fluoranthene	-	-	-
	Fluorene	-	-	-
	Indeno[123-c,d] pyrene	-	-	-
	Naphthalene	-	-	-
	Phenanthrene	-	-	-
Pyrene	-	-	-	

Notes:

Dashes ( - ) indicate where measurement data are not available for a particular parameter, in a particular medium.

Blanks indicate where a parameter has undergone screening and was not identified as a COPC.

N/A – Not Applicable.



## 4.5 Additional Media: Air, Stormwater and Sediment

While not used in the preliminary or secondary screening, contaminant levels in air, stormwater and sediment are still useful in the risk assessment. Information on these media is presented below.

### **Air**

Air dispersion modeling, based on emissions data from the facility, was used to predict air deposition at receptor locations. Deposition of contaminants from air onto soil and/or garden produce is a potential pathway for the human health risk assessment.

Table 4.5 presents total, site-wide emission rates and modelled maximum concentrations in air, based on either ½-hour, 1-hour, 24-hour, 30-day, or 12-month (annual) averaging periods, derived using AERMOD model results as reported in Cameco (2014). It is noted that the estimates provided in the emission summary table (and used in the screening below) are conservative estimates rather than actual emission rates. Also, they do not yet reflect the substantial reduction in uranium and hydrogen fluoride emissions that was achieved by upgrading a tail gas venturi scrubber on the UF<sub>6</sub> main stack in 2014. These data are expected to be updated following third-party verification in 2015.

For illustrative purposes, these concentrations are compared to air quality criteria obtained from the following sources:

- MOE (2012a) *Ambient Air Quality Criteria (AAQCs) guidelines*;
- MOE (2012b) *Summary of Standards and Guidelines to support Ontario Regulation 419/05 – Air Pollution – Local Air Quality*, and
- MOE (2008a) *Jurisdictional Screening Level (JSL) List*.

In the illustrative comparison shown below, heavy metals (including uranium) and aluminum are compared to 10% of their respective POI criteria as opposed to the full POI criteria values. This is a conservative approach, made to accommodate deposition and potential build-up in soil and account for cumulative effects from other pathways.

Final – Environmental Risk Assessment for the Cameco Port Hope Conversion Facility

Table 4.5 Air Quality Data and Comparison to Guidelines

Parameter	Emission Rate (g/s)	Averaging Period (hours)	AERMOD Maximum POI ( $\mu\text{g}/\text{m}^3$ )	MOECC POI Criteria ( $\mu\text{g}/\text{m}^3$ )	Basis for Standard	% of Criteria (%)
Al	9.08E-04	24	9.75E-03	0.48 <sup>5</sup>	Screening	20.3
NH <sub>3</sub>	2.69E+00	24	5.90E+01	100	Health	59
Sb	3.92E-06	24	4.00E-05	2.5 <sup>5</sup>	Health	0.016
As (and compounds)	4.25E-06	24	5.20E-04	0.03 <sup>5</sup>	Health	17
B	4.25E-06	24	4.57E-03	12 <sup>5</sup>	Particulate	0.38
Cd (and compounds)	1.00E-06	24	1.00E-05	0.0025 <sup>5</sup>	Health	4.0
CO	3.54E-01	1/2	3.75E+01 <sup>1</sup>	6000	Health	0.6
Cr (II & III forms)	2.90E-05	24	3.10E-04 <sup>2</sup>	0.05 <sup>5</sup>	Health	6.2
Cu	5.04E-05	24	5.40E-04	5 <sup>5</sup>	Health	0.11
Fluorides (as gaseous HF; growing season)	1.86E-02	24	4.30E-01	0.86	Vegetation	50
Fluorides (as gaseous HF; growing season)	1.86E-02	30-day	1.16E-01	0.34	Vegetation	34
Fluorine	4.52E-04	24	8.40E-03	0.1	N/A	<De minimis
Hydrogen Sulphide	3.50E-04	24	2.00E-02	7	Health	0.29
Pb (and compounds)	2.49E-05	24	2.70E-04	0.05 <sup>5</sup>	Health	5.4
Pb (and compounds)	2.49E-05	30-day	5.00E-05	0.02 <sup>5</sup>	Health	2.5
Mg	3.03E-04	24	3.25E-03	0.2	Screening	<JSL
Mn	7.93E-05	24	8.50E-04	0.04 <sup>5</sup>	Health	21
Mo	6.89E-05	24	7.40E-04	12 <sup>5</sup>	Particulate	0.062
Ni (and compounds)	3.21E-05	24	3.40E-04	0.02 <sup>5</sup>	Health	17
Ni (and compounds)	3.21E-05	24	3.40E-04	0.2 <sup>5</sup>	Vegetation	1.7
NO <sub>x</sub>	2.08E+00	24	1.03E+02	200	Health	52
NO <sub>x</sub>	2.08E+00	1	2.55E+02	400	Health	64
PM	3.91E-01	24	1.44E+01	50	Health	29
P	1.31E-03	24	1.41E-02	0.35	Screening	<JSL

Final – Environmental Risk Assessment for the Cameco Port Hope Conversion Facility

Parameter	Emission Rate (g/s)	Averaging Period (hours)	AERMOD Maximum POI ( $\mu\text{g}/\text{m}^3$ )	MOECC POI Criteria ( $\mu\text{g}/\text{m}^3$ )	Basis for Standard	% of Criteria (%)
K	1.56E-02	24	5.53E-02	8	Screening	<JSL
Potassium Hydroxide	6.31E-04	24	5.53E-02	14	Corrosion	0.4
Se	1.18E-04	24	1.27E-03	1 <sup>5</sup>	Health	1.3
Na	1.01E-03	24	1.09E-02	0.1	N/A	<De minimis
Sr	5.27E-06	24	6.00E-05	12 <sup>5</sup>	Particulate	0.005
Sulphur Dioxide	2.01E+00	24	2.99E+01	275	Health & Vegetation	11
Sulphur Dioxide	2.01E+00	1	1.78E+02	690	Health & Vegetation	26
TCE	2.46E-05	24	2.99E-03	12	Health	0.025
Sn	1.18E-04	24	1.27E-03	1 <sup>5</sup>	Health	1.3
U (and compounds)	2.51E-03 <sup>3</sup>	Annual	6.50E-03	0.003 <sup>4,5</sup>	Health	217
Vinyl Chloride	1.60E-06	24	1.90E-04	1	Health	0.019
Zn	8.33E-05	24	8.90E-04	12 <sup>5</sup>	Particulate	0.074

Notes:

- <sup>1</sup> The 1-hr concentration for CO was converted to ½-hr concentration using conversion factor of 1.2.
  - <sup>2</sup> Source testing results are for total Cr only. Total Cr concentration compared to di- and tri-valent Cr guidelines, after July 1 2016, annual standard.
  - <sup>3</sup> PHCF U emission rate based on TSP fraction (TSP > PM<sub>10</sub>).
  - <sup>4</sup> Schedule 3 of MOECC POI Standard for U and U Compounds in the PM<sub>10</sub> size fraction, based on kidney toxicity, effective July 1, 2016.
  - <sup>5</sup> Heavy metals (and Al) compared to 10% of POI criterion, to accommodate deposition and potential build-up in soil and account for cumulative effects from other pathways.  
De minimis - *de minimis* level of 0.1  $\mu\text{g}/\text{m}^3$  (24-averaging time) or 0.3  $\mu\text{g}/\text{m}^3$  (½-averaging time), as mentioned in MOE (2008) JSL Guidance.  
JSL - Jurisdictional Screening Level from List published by Standards Development Branch, February 2008, PIBS#6547e, Version 1.
- N/A - Not applicable.

None of the contaminants exceed their respective screening criteria. Uranium was found to exceed its modified screening criterion in air, which is 10% of the actual POI (i.e., very conservative). Air dispersion modelling (discussed in detail in Section 3.0) and deposition calculations were carried out for uranium.

### Stormwater

Measured stormwater concentrations are indicative of conditions that exist within the storm sewer system. As measured, stormwater is essentially inaccessible to human and ecological receptors while it is located within the storm sewer system. Stormwater only becomes accessible to ecological and human receptors once it is discharged into the Harbour, at which point it becomes diluted in the surrounding surface water.

Direct surface water measurements, which are available, are representative of the conditions that exist in the Harbour. These direct surface water measurements implicitly encompass any contaminants contributed by stormwater. The stormwater concentrations are used, however, as input in the surface water modelling described in Section 3.0, in order to estimate the impact of current plant operations.

Maximum measured stormwater concentrations are presented in Table 4.6, along with the surface water screening criteria (and criteria from the Port Hope Sewer Use Bylaw), for illustrative purposes.

Table 4.6 Stormwater Data

Parameter	Units	Screening Criteria	Maximum Stormwater Conc.
pH	units	6.5-8.5 <sup>1</sup>	9.02
Conductivity	µS/cm	NA	905
Alkalinity	mg/L as CaCO <sub>3</sub>	3 <sup>1</sup>	197
CO <sub>3</sub>	mg/L as CaCO <sub>3</sub>	NA	< 2
HCO <sub>3</sub>	mg/L as CaCO <sub>3</sub>	NA	197
OH	mg/L as CaCO <sub>3</sub>	NA	< 2
Fluoride	mg/L	0.12 <sup>2</sup>	9.5
TDS	mg/L	NA	597
Sulphate	mg/L	309 <sup>9</sup>	210
Chloride	mg/L	1500 <sup>10</sup>	200
Nitrite	as N mg/L	0.197 <sup>2</sup>	< 0.3
Nitrate	as N mg/L	13 <sup>2</sup>	6.05
Phenolics	mg/L	0.001 <sup>1</sup>	0.022
Ammonia (Total)	as N mg/L	0.0995 <sup>2</sup>	0.6
DOC	mg/L	NA	10.9
Cyanide (Total)	mg/L	0.005 <sup>1</sup>	0.05
E.coli	cfu/100mL	100 <sup>1</sup>	3440

Final – Environmental Risk Assessment for the Cameco Port Hope Conversion Facility

Parameter	Units	Screening Criteria	Maximum Stormwater Conc.
Total Coliform	cfu/100mL	1000 <sup>1</sup>	9600
Hardness	mg/L as CaCO <sub>3</sub>	NA	558
TSS	mg/L	15 <sup>10</sup>	600
BOD	mg/L	15 <sup>10</sup>	7
Oil and grease (tot)	mg/L	NA	2
Hg	mg/L	0.0002	0.00006
Ag	mg/L	0.0001 <sup>1</sup>	0.00056
Al	mg/L	0.075 <sup>1,4</sup>	7.58
As	mg/L	0.005 <sup>1,5,6</sup>	0.0257
Ba	mg/L	NA	0.0557
Be	mg/L	1.1 <sup>1,7</sup>	0.00024
B (Total)	mg/L	0.2 <sup>1</sup>	0.101
Bi	mg/L	NA	0.0011
Ca	mg/L	NA	211
Cd	mg/L	0.0005 <sup>1,5,6,7</sup>	0.000657
Co	mg/L	0.0009 <sup>1</sup>	0.00488
Cr	mg/L	0.0089 <sup>1,8</sup>	0.0119
Cu	mg/L	0.005 <sup>1,5,6,7</sup>	0.138
Fe	mg/L	0.3 <sup>1</sup>	7.72
K	mg/L	NA	23.9
Mg	mg/L	NA	8.54
Mn	mg/L	0.8 <sup>9</sup>	0.308
Mo	mg/L	0.04 <sup>1</sup>	0.00503
Na	mg/L	NA	91.3
Ni	mg/L	0.025 <sup>1</sup>	0.114
P	mg/L	0.02 <sup>1,5</sup>	0.957
Pb	mg/L	0.005 <sup>1,5,6,7</sup>	0.0347
Sb	mg/L	0.02 <sup>1,5</sup>	0.0049
Se	mg/L	0.1 <sup>1</sup>	0.004
Si	mg/L	NA	17.5
Sr	mg/L	NA	0.466
Ti	mg/L	NA	0.188
Tl	mg/L	0.0003 <sup>1,5</sup>	< 0.0002
U	mg/L	0.005 <sup>1,5</sup>	0.43

Final – Environmental Risk Assessment for the Cameco Port Hope Conversion Facility

Parameter	Units	Screening Criteria	Maximum Stormwater Conc.
V	mg/L	0.006 <sup>1, 5</sup>	0.0115
Zn	mg/L	0.02 <sup>1, 5, 6</sup>	0.843
F1 (C6-C10)	µg/L	NA	< 25
F2 (C10-C16)	µg/L	NA	< 100
F3 (C16-C34)	µg/L	NA	< 500
F4 (C34-C50)	µg/L	NA	581
Benzene	µg/L	100 <sup>1, 5</sup>	< 1
Ethylbenzene	µg/L	8 <sup>1, 5</sup>	< 1
Toluene	µg/L	0.8 <sup>1, 5</sup>	< 1
Xylene (total)	µg/L	72 <sup>1, 5</sup>	< 1
Ra-226	mBq/L	1000 <sup>1</sup>	140
Po-210	Bq/L	NA	19
Pb-210	Bq/L	NA	14
Ra-224	Bq/L	NA <sup>11</sup>	1.3
Ra-228	Bq/L	NA	1.3
Th-228	Bq/L	NA	0.9
Th-230	Bq/L	NA	22
Th-232	Bq/L	NA	0.3
U-234	Bq/L	NA	46
U-235	Bq/L	NA	1.7
U-238	Bq/L	NA	49

Notes:

NA – not available.

<sup>1</sup> MOE (1999) *Provincial Water Quality Objectives*.

<sup>2</sup> CCME (2014, online) *Water Quality Guidelines for Protection of Aquatic Life*.

<sup>3</sup> Narrative statement that alkalinity should not be decreased by more than 25% of natural levels.

<sup>4</sup> For pH>6.5-9, measured on a clay-free sample.

<sup>5</sup> Interim PWQO. Interim PWQOs were set for emergency purposes based on the best information readily available. Employ due caution when applying these values.

<sup>6</sup> Both a PWQO exists, as well as an IPWQO. The IPWQO for hardness > 100 mg/L is listed.

<sup>7</sup> Objective is dependent on hardness, value shown is for high hardness water based on site-specific considerations.

<sup>8</sup> Value shown is for trivalent chromium, a value of 1 µg/L is also available for hexavalent chromium.

<sup>9</sup> BC MOE (2014, online) screening criteria, based on most restrictive water hardness.

<sup>10</sup> PH (1994) *Town of Port Hope Sewer Use By-Law (30/94)*.

<sup>11</sup> Ra-224 concentration set equal to Ra-228, using secular equilibrium.

Radionuclide data are from 2009-2010 monitoring, other than Ra-226 which is from 2014.

The above comparison shows that maximum concentrations of the following contaminants in stormwater exceed surface water criteria:

- Fluoride
- Nitrate
- Nitrite
- Ammonia (total)
- Phenolics
- CN (T)
- E.Coli
- Total Coliform
- TSS
- Al
- As
- Cd
- Co
- Cr
- Cu
- Fe
- Ni
- P
- Pb
- U
- V
- Zn

In addition, the maximum pH is outside of the expected range in surface water.

Most of these contaminants have been identified as COPCs in soil, groundwater or surface water, and will undergo further evaluation, or have been evaluated and screened out in other media, such as chromium.

### ***Sediment***

The off-site sediment concentrations can be compared to guidelines to gain perspective on contaminant levels; however, it is important to understand the limitations of such a comparison.

Sediments in the Port Hope Harbour have been impacted by contamination from many sources, and much of it is attributed to historical industrial use of the surrounding lands, and not to current PHCF operations. Examples of historical uses include coal stockpiling, foundry operations and radium refining. Sediment screening would inevitably identify several contaminants at levels exceeding their corresponding criteria, and furthermore, subsequent ecological risk assessment would inevitably identify many contaminants as posing potential risk. However, such findings would then be qualified with discussions on the nature of the contamination and the underlying fact that it is not due to current site operations at the PHCF, thus ultimately returning to the initial consideration.

Direct surface water measurement data are representative of the conditions that exist in the Harbour, and, they implicitly reflect contaminant levels resulting from sediment-water interactions. The risk assessment therefore relies preferentially on the surface water data to assess the aquatic environment.

Maximum measured Sediment concentrations are presented in Table 4.7. For illustrative purposes, these concentrations are compared to the following sediment criteria (in the following hierarchy):

1. MOE (2011) Soil, Groundwater and Sediment Standards - Table 1 values.
2. MOE (2008b) Sediment Quality Guidelines.
3. Thompson, Kurias, Mihok (2005) - Derived Sediment Screening Levels: Table 1, Weighted Lowest-Effect-Levels.
4. CCME (1998) Interim Sediment Quality Guidelines (online, October 2014).



Table 4.7 Maximum Measured Sediment Concentrations

Category	Parameter	Units	Screening Criteria		Maximum Sediment Concentration
Metals	Ag	µg/g	0.5	1	2.8
	Al	µg/g	NV	1	19200
	As	µg/g	6	1	800
	Ba	µg/g	NV	1	170
	Be	µg/g	NV	1	0.7
	B (total)	µg/g	NV	1	<1
	Ca	µg/g	NA		81700
	Cd	µg/g	0.6	1	0.6
	Co	µg/g	50	1	85
	Cr	µg/g	26	1	37
	Cu	µg/g	16	1	180
	Fe	µg/g	20000	2	23900
	Hg	µg/g	0.2	1	0.65
	Mg	µg/g	NA		9000
	Mn	µg/g	460	2	690
	Mo	µg/g	13.8	3	3.5
	Ni	µg/g	16	1	29
	Pb	µg/g	31	1	1800
	Se	µg/g	1.9	3	0.6
	Sb	µg/g	NV	1	0.4
	Sn	µg/g	NA		3.4
	Sr	µg/g	NA		230
	Ti	µg/g	NA		1300
Tl	µg/g	NV	1	<0.2	
U	µg/g	104.4	3	338	
V	µg/g	35.2	3	34	
Zn	µg/g	120	1	180	
Rad	Ra-226	Bq/g	NA		103

Category	Parameter	Units	Screening Criteria		Maximum Sediment Concentration
PAHs	Acenaphthene	µg/g	0.00671	4	0.03
	Acenaphthylene	µg/g	0.00587	4	0.04
	Anthracene	µg/g	0.22	1	0.14
	Benzo[a] anthracene	µg/g	0.32	1	0.58
	Benzo[a] pyrene	µg/g	0.37	1	0.63
	Benzo[b] fluoranthene	µg/g	NV	1	0.55
	Benzo[k] fluoranthene	µg/g	0.24	1	0.44
	Benzo[ghi] perylene	µg/g	0.17	1	0.33
	Chrysene	µg/g	0.34	1	0.52
	Dibenzo[a,h] anthracene	µg/g	0.06	1	0.19
	Fluoranthene	µg/g	0.75	1	0.88
	Fluorene	µg/g	0.19	1	0.39
	Indeno[123-c,d] pyrene	µg/g	0.2	1	0.39
	Naphthalene	µg/g	0.0346	4	0.17
	Phenanthrene	µg/g	0.56	1	0.37
Pyrene	µg/g	0.49	1	0.66	

Category	Parameter	Units	Screening Criteria	Maximum Sediment Concentration
Radionuclides	Pb-210	Bq/g	NA	71
	Po-210 <sup>5</sup>	Bq/g	NA	71
	Ra-224 <sup>6</sup>	Bq/g	NA	0.025
	Ra-226	Bq/g	NA	103.3
	Ra-228 <sup>5,6</sup>	Bq/g	NA	0.025
	Th-228 <sup>6</sup>	Bq/g	NA	0.15
	Th-230	Bq/g	NA	110
	Th-232 <sup>6</sup>	Bq/g	NA	0.15
	U-234 <sup>7</sup>	Bq/g	NA	4.2
	U-235 <sup>7</sup>	Bq/g	NA	0.19
	U-238 <sup>7</sup>	Bq/g	NA	4.2

Notes:

Sediment concentration data are from 2003, 2007 and 2008 sampling activities.

<sup>1</sup> MOE (2011) Soil, Groundwater and Sediment Standards – Table 1 values.

<sup>2</sup> MOE (2008) Sediment Quality Guidelines.

<sup>3</sup> Thompson, Kurias, Mihok (2005) - Derived Sediment Screening Levels: Table 1, Weighted Lowest-Effect-Levels.

<sup>4</sup> CCME (1998) Interim Sediment Quality Guidelines (online, October 2014).

<sup>5</sup> Based on secular equilibrium, Po-210 set equal to Pb-210 and Ra-228 set equal to Ra-224.

<sup>6</sup> Sediment concentration estimated by applying Kd (water-sediment equilibrium distribution coefficient) to harbour water concentration. Note: harbour water levels were below detection limit and therefore set to half of detection limit.

<sup>7</sup> Estimated from natural uranium concentration, based on specific activity.

NV – ‘No Value’ designation from MOE (2011).

NA – Not Available.

## 4.6 Gamma

For the purposes of this risk assessment update, all radionuclide and gamma measurement data are screened-in (i.e., are identified as stressors), and will undergo further risk evaluation.

The radionuclide concentrations used in the HHRA and EcoRA are presented in the Exposure Point Concentration tables in Sections 5 and 6 respectively. The 2014 fence line gamma levels measured by Cameco are presented below. [REDACTED] These values have been corrected for background of 8 µR/h.

Final – Environmental Risk Assessment for the Cameco Port Hope Conversion Facility

Table 4.8 2014 Measured Fenceline Gamma Data

Station #	First Quarter		Second Quarter		Third Quarter		Fourth Quarter		Year to Date	
	Average	Maximum	Average	Maximum	Average	Maximum	Average	Maximum	Average	Maximum
	ur/h	ur/h	ur/h	ur/h	ur/h	ur/h	ur/h	ur/h	ur/h	ur/h
1	-3.684	-3.089	-2.821	-2.290	-1.833	-0.424	-1.879	0.816	-2.554	0.816
2	21.286	22.247	24.821	25.602	19.870	22.025	21.953	23.466	21.983	25.602
3	0.664	1.226	4.112	5.889	3.033	4.990	2.415	3.461	2.556	5.889
4	14.956	17.758	16.582	22.556	20.201	21.534	18.587	20.967	17.582	22.556
5	-2.103	-0.929	7.401	11.231	12.396	14.794	8.740	11.684	6.608	14.794
6	0.479	1.091	3.680	5.301	4.338	6.706	4.313	4.720	3.203	6.706
7	-0.407	1.970	1.683	2.000	0.479	1.069	0.185	1.626	0.485	2.000
8	5.147	6.286	8.399	8.806	6.894	9.424	5.934	6.610	6.593	9.424
9	-2.857	-1.813	-0.667	0.974	-1.178	-0.157	-1.692	-0.960	-1.599	0.974
10	-3.668	-2.444	-0.526	1.135	-1.216	-0.157	-2.471	-1.247	-1.970	1.135
11	-1.680	-1.308	0.137	1.005	-1.075	-1.015	-0.515	0.186	-0.783	1.005
12	-1.949	-1.155	-0.614	-0.308	-1.223	-0.929	-1.503	-0.569	-1.322	-0.308
13	0.769	1.470	2.921	4.778	2.512	3.012	3.016	3.335	2.305	4.778
14	-0.434	-0.298	0.257	0.611	-0.237	0.207	1.485	3.063	0.268	3.063
15	4.089	5.636	7.811	8.398	5.526	7.025	6.482	7.365	5.977	8.398
16	1.472	2.354	4.444	5.194	3.424	4.745	3.679	5.098	3.255	5.194
17	-2.175	-1.452	-2.307	-1.145	-2.729	-1.873	-0.869	0.477	-2.020	0.477
18	9.260	10.056	12.847	14.115	13.038	16.265	13.492	14.989	12.159	16.265
19	-1.903	-1.687	0.351	2.618	-1.128	-0.279	-0.156	0.046	-0.709	2.618
20	2.492	4.649	2.982	3.378	1.639	2.049	1.830	2.579	2.236	4.649
21	2.142	2.714	5.868	6.861	6.066	7.319	7.677	8.499	5.438	8.499
22	1.770	4.626	4.329	5.172	4.214	4.868	5.263	6.224	3.894	6.224
23	1.397	3.237	2.872	3.859	1.889	3.887	2.775	3.207	2.233	3.887
24	1.086	2.268	1.353	2.880	0.469	2.662	2.010	2.453	1.230	2.880

Final – Environmental Risk Assessment for the Cameco Port Hope Conversion Facility

Station #	First Quarter		Second Quarter		Third Quarter		Fourth Quarter		Year to Date	
	Average	Maximum	Average	Maximum	Average	Maximum	Average	Maximum	Average	Maximum
	ur/h	ur/h	ur/h	ur/h	ur/h	ur/h	ur/h	ur/h	ur/h	ur/h
25	-5.088	-3.972	-4.395	-4.111	-4.388	-3.343	-4.007	-2.332	-4.470	-2.332
31	-5.316	-4.914	-3.061	-2.028	-4.026	-3.221	-3.649	-2.710	-4.013	-2.028
32	-2.286	-1.434	-1.096	-0.204	5.252	10.382	-1.428	-0.947	0.110	10.382
33	1.159	2.417	5.067	7.545	1.004	4.351	3.138	4.469	2.592	7.545

## 4.7 Uncertainties in Preliminary COPC Screening

- The screening methodology has been set up to minimize uncertainty: in the absence of screening criteria, contaminants are 'screened-in', i.e., retained as COPCs.
- The main uncertainties in the preliminary screening process are likely to be gaps in the data and gaps in the available screening criteria. As discussed earlier, large gaps were not identified in the ERA data set. In the absence of MOE screening criteria, other values such as background levels were used for screening. Degree of uncertainty: Low.
- Secondary screening, based on human health and ecological component values, is conducted and discussed in later sections of this report.

## 5 HUMAN HEALTH RISK ASSESSMENT

A HHRA is the evaluation of the probability of health consequences to humans caused by the presence of chemical contaminants at a Site. To assess this probability it is necessary to take receptor characteristics, exposure pathways and mitigating circumstances into consideration. The assessment of levels of unacceptable risk is evaluated using: toxicological information associated with the particular contaminants of concern; chemical and physical Site conditions; and known characteristics of the people using the Site.

The requirement for, approach to, and scope of, a HHRA is based on a fundamental understanding of: site conditions, including the nature, extent and distribution of the radiological and chemical hazards; the potential exposure pathways; and opportunities for human receptors that will frequent, use or populate the site. The following sections describe the HHRA and its components.

### 5.1 Problem Formulation

#### 5.1.1 Receptor Selection & Characterization

The selection and characterization of human receptors was based on:

- the guidance provided in Health Canada (2012a), CSA N288.1 (2014) and CSA N288.6 (2012);
- the detailed human receptor identification undertaken as part of the SWRA (SENES 2009a), with additional receptors added near the Dorset Street East warehouse, for consistency with other Cameco projects such as Vision In Motion; and
- input from stakeholders, including regulators and members of the public (also a requirement of CSA N288.6).

The estimated exposure of the off-site members of the public has been characterized to bound any potential exposure of local residents as well as other members of the public who fish and swim in Lake Ontario.

It is important to note that all human receptors obtain drinking water from the municipal drinking water system, and not from groundwater or surface water. Therefore, groundwater and surface water ingestion as drinking water is excluded for all human receptors.

Table 5.1 presents the complete list of human receptors along with their descriptions. The receptor locations are illustrated on Figure 5.1.

Final – Environmental Risk Assessment for the Cameco Port Hope Conversion Facility

Table 5.1 HHRA: Identification of Human Receptors

Type of Receptor	Receptor Name	Description	Age Variants
On-Site Worker	On-Site Worker	<p>An on-site worker with the potential to be involved in a variety of activities, including:</p> <ul style="list-style-type: none"> <li>soil subsurface investigations or construction activities; and</li> <li>collection of groundwater samples.</li> </ul> <p>This receptor is assumed to come into direct contact with soil (anywhere on-site, excluding soil beneath buildings) and groundwater (anywhere on-site) for short periods of time. This receptor is assumed to be potentially present in the long-term (i.e., for several years), therefore warranting assessment of chronic effects.</p> <p>The on-site worker receptor does not engage in swimming activities, and is located within the facility boundary (i.e., not along the harbour, and therefore cannot fall into the harbour).</p>	Adult only
Off-Site Member of the Public	<p>Nearby Resident – Hayward &amp; Alexander</p> <p>Receptor ID: REAH</p>	<p>A local resident who:</p> <ul style="list-style-type: none"> <li>lives on a street near the PHCF (e.g., Hayward &amp; Alexander Streets);</li> <li>potentially consumes local fish from Lake Ontario caught near the pier/harbour (excluding infants);</li> <li>swims in Lake Ontario (at the beaches west of the PHCF);</li> <li>walks the fenceline (adult only);</li> <li>has the potential to fall into the harbour (excluding infants); and</li> <li>has a garden from which they grow and consume produce.</li> </ul> <p>These assumed exposure pathways are included to ensure a conservative estimate of risk (i.e., it is unlikely that any human is involved in all of these activities at the rates assumed in this study). Chronic (long-term) effects are evaluated, which would encompass any short-term exposure.</p> <p>This nearby resident receptor is also assessed for direct external gamma exposure from the PHCF facility.</p>	<p><b>Rad*:</b></p> <p>Infant Child Adult</p> <p><b>Non-Rad*:</b></p> <p>Infant Toddler Child Teen Adult</p>
Off-Site Member of the Public	<p>Nearby Resident – Ganaraska</p> <p>Receptor ID: REMM</p>	<p>A local resident who:</p> <ul style="list-style-type: none"> <li>lives on a street along the east bank of the Ganaraska River (e.g., Mill &amp; Madison Streets);</li> <li>potentially consumes local fish from Lake Ontario caught near the pier/harbour (excluding infants);</li> <li>swims in Lake Ontario (at the beaches west of the PHCF);</li> <li>has the potential to fall into the harbour (excluding infants); and</li> <li>has a garden from which they grow and consume produce.</li> </ul> <p>These assumed exposure pathways are included to ensure a conservative estimate of risk (i.e., it is unlikely that any human is involved in all of these activities at the rates assumed in this study). Chronic (long-term) effects are evaluated, which would encompass any short-term exposure.</p>	<p><b>Rad*:</b></p> <p>Infant Child Adult</p> <p><b>Non-Rad*:</b></p> <p>Infant Toddler Child</p>



Final – Environmental Risk Assessment for the Cameco Port Hope Conversion Facility

Type of Receptor	Receptor Name	Description	Age Variants
		This nearby resident receptor is also assessed for direct external gamma exposure from the PHCF facility.	Teen Adult
Off-Site Member of the Public	Nearby Resident – Dorset Facility Area  Receptor ID: REDWSE	<p>A local resident who:</p> <ul style="list-style-type: none"> <li>lives on a street near the Dorset Street Warehouse Facility, specifically in a neighbourhood SE of the facility (e.g., bounded by Dorset Street East, Peter Street, Nelson Street and Rose Glen Road);</li> <li>potentially consumes local fish from Lake Ontario caught near the pier/harbour (excluding infants);</li> <li>swims in Lake Ontario (at the beaches west of the PHCF);</li> <li>has the potential to fall into the harbour (excluding infants); and</li> <li>has a garden from which they grow and consume produce.</li> </ul> <p>These assumed exposure pathways are included to ensure a conservative estimate of risk (i.e., it is unlikely that any human is involved in all of these activities at the rates assumed in this study). Chronic (long-term) effects are evaluated, which would encompass any short-term exposure.</p> <p>This nearby resident receptor is also assessed for direct external gamma exposure from the Dorset Street facility.</p>	<p><b>Rad*:</b> Infant Child Adult</p> <p><b>Non-Rad*:</b> Infant Toddler Child Teen Adult</p>
Off-Site Member of the Public	Recreational Fisherpersion  Receptor ID: FWG1	<p>A person engaged in fishing in the harbour, who:</p> <ul style="list-style-type: none"> <li>spends short periods of time fishing in the harbour near the PHCF facility (specifically, in the most south-eastern portion of the grass strip);</li> <li>is not a resident, and therefore does not grow and consume local garden produce;</li> <li>does catch and consume fish from the harbour;</li> <li>does not engage in swimming activities; and</li> <li>is assumed not to have the potential to fall into the harbour.</li> </ul> <p>The fisherpersion receptor is assessed for direct external gamma exposure since they are located adjacent to the PHCF site.</p>	Adult only
Off-Site Member of the Public	Recreational Boater/Yacht Club User – NE side of Turning Basin  Receptor ID: RYED5	<p>A recreational boat user, or a member of the yacht club, who:</p> <ul style="list-style-type: none"> <li>spends short periods of time on land near the yacht club site (specifically the NE side of the turning basin), and on a boat in the harbour near the PHCF facility;</li> <li>does not grow and consume local garden produce;</li> <li>does not engage in swimming activities;</li> <li>does not catch or consume fish from the harbour; and</li> <li>has the potential to fall into the harbour.</li> </ul>	Adult only

Final – Environmental Risk Assessment for the Cameco Port Hope Conversion Facility

Type of Receptor	Receptor Name	Description	Age Variants
		The recreational boater/yacht club user receptor is also assessed for direct external gamma exposure since they are located adjacent to the PHCF site and Centre Pier.	
Off-Site Member of the Public	Recreational Boater/Yacht Club User – NW side of Turning Basin  Receptor ID: RYED4	<p>A recreational boat user, or a member of the yacht club, who:</p> <ul style="list-style-type: none"> <li>spends short periods of time on land near the yacht club site (specifically the NW side of the turning basin), and on a boat in the harbour near the PHCF facility;</li> <li>does not grow and consume local garden produce;</li> <li>does not engage in swimming activities;</li> <li>does not catch or consume fish from the harbour; and</li> <li>has the potential to fall into the harbour.</li> </ul> <p>The recreational boater/yacht club user receptor is also assessed for direct external gamma exposure since they are located adjacent to the PHCF site and Centre Pier.</p>	Adult only
Off-Site Member of the Public	Fenceline Walker  Numerous Receptor IDs	<p>Represents a member of the public that spends recreational time (1 h/day, year-round) walking the fenceline around PHCF. This receptor:</p> <ul style="list-style-type: none"> <li>inhales outdoor air; and</li> <li>is not expected may come into contact with soil or incidentally ingest soil.</li> </ul> <p>The recreational fenceline walker receptor is assessed for direct external gamma exposure, since they are located near the PHCF.</p>	Adult only
Off-Site Member of the Public	Recreational Park User  Receptor ID: RPK1	<p>Represents a member of the public that spends recreational time (1 h/day, year-round) at the park near the Dorset Street East Warehouse. This receptor:</p> <ul style="list-style-type: none"> <li>may come into contact with soil;</li> <li>may incidentally ingest some soil; and</li> <li>inhales outdoor air.</li> </ul> <p>This is a conservative exposure scenario, as the receptor is not expected to come into contact with soil year-round.</p> <p>The recreational park user receptor is assessed for direct external gamma exposure, since they are located near the Dorset Street East Warehouse.</p>	<p><b>Rad*:</b> Infant Child Adult</p> <p><b>Non-Rad*:</b> Infant Toddler Child Teen Adult</p>
Off-Site Member of the Public	Downtown Commercial Worker	<p>Represents a member of the public that does not reside in close proximity to the PHCF, but works in the commercial downtown area of Port Hope, specifically Walton &amp; Ontario Streets. This receptor:</p> <ul style="list-style-type: none"> <li>does not engage in soil-related activities (e.g., gardening);</li> <li>does not spend time near the PHCF (i.e., in the harbour or the fenceline grass patch area);</li> </ul>	Adult only

Final – Environmental Risk Assessment for the Cameco Port Hope Conversion Facility

Type of Receptor	Receptor Name	Description	Age Variants
	Receptor ID: COWO	<ul style="list-style-type: none"> <li>• does not grow and consume local garden produce;</li> <li>• does not catch and consume fish from the harbour;</li> <li>• does not have the potential to fall into the harbour; and</li> <li>• does not engage in swimming activities.</li> </ul> <p>Despite being located far from potential sources (e.g., the PHCF, Centre Pier or Dorset Street warehouse), the downtown commercial worker receptor is assessed for direct external gamma exposure.</p>	
Off-Site Member of the Public	Commercial Worker: East Bank of Ganaraska  Receptor ID: CODp1	<p>Represents a member of the public that does not reside in close proximity to the PHCF, but works along the east bank of the Ganaraska River, specifically Mill &amp; Shuter Streets. This receptor:</p> <ul style="list-style-type: none"> <li>• does not engage in soil-related activities (e.g., gardening);</li> <li>• does not spend time near the PHCF (i.e., in the harbour or the fenceline grass patch area);</li> <li>• does not grow and consume local garden produce;</li> <li>• does not catch and consume fish from the harbour;</li> <li>• does not have the potential to fall into the harbour; and</li> <li>• does not engage in swimming activities.</li> </ul> <p>The commercial worker receptor is assessed for direct external gamma exposure, since they are located near the Centre Pier.</p>	Adult only
Off-Site Member of the Public	Commercial Worker: West of Building 50 Boundary (Garage)  Receptor ID: COA1	<p>Represents a member of the public that does not reside in close proximity to the PHCF, but works at a garage west of Building 50. This receptor:</p> <ul style="list-style-type: none"> <li>• does not engage in soil-related activities (e.g., gardening);</li> <li>• does not spend time near the PHCF (i.e., in the harbour or the fenceline grass patch area);</li> <li>• does not grow and consume local garden produce;</li> <li>• does not catch and consume fish from the harbour;</li> <li>• does not have the potential to fall into the harbour; and</li> <li>• does not engage in swimming activities.</li> </ul> <p>The commercial worker receptor is assessed for direct external gamma exposure, since they are located near the PHCF site.</p>	Adult only

Final – Environmental Risk Assessment for the Cameco Port Hope Conversion Facility

Type of Receptor	Receptor Name	Description	Age Variants
Off-Site Member of the Public	Commercial Worker:Dorset Facility Area  Receptor ID: COK1	<p>Represents a member of the public that does not reside in close proximity to the PHCF, but works near the Dorset Street warehouse facility, specifically Dorset Street near Nelson. This receptor:</p> <ul style="list-style-type: none"> <li>• does not engage in soil-related activities (e.g., gardening);</li> <li>• does not spend time near the PHCF (i.e., in the harbour or the fenceline grass patch area);</li> <li>• does not grow and consume local garden produce;</li> <li>• does not catch and consume fish from the harbour;</li> <li>• does not have the potential to fall into the harbour; and</li> <li>• does not engage in swimming activities.</li> </ul> <p>The commercial worker receptor is assessed for direct external gamma exposure, since they are located near the Dorset Street warehouse.</p>	Adult only
Commercial Worker & Off-Site Member of the Public	Worker + Resident	<p>Included as a conservative measure, the 'Worker + Resident' is a receptor that is both a commercial worker in Port Hope and a nearby resident, including all related pathways and exposures. The 'Worker + Resident' receptor:</p> <ul style="list-style-type: none"> <li>• experiences all commercial worker pathways and exposures, and is potentially present in the long-term (i.e., for several years); and</li> <li>• experiences all active off-site public pathways and exposures of the adult 'Nearby Resident' receptor.</li> </ul>	Adult only

Notes:

\* Age groups recommended for radiological assessment as per CSA N288.1 (2014). Age groups recommended for non-radiological assessment as per CSA N288.6 (2012).

In addition to the above, some receptors have been added together, as an additional measure of conservatism. These compounded receptors include:

- Commercial Worker + Resident;
- Fenceline Walker + Resident;
- Park User + Resident;
- Yacht Club Member + Resident; and
- Fisherperson + Resident.

Doses to these individuals are also estimated and presented in this report.

Final – Environmental Risk Assessment for the Cameco Port Hope Conversion Facility

Figure 5.1. Human Health Receptor Locations

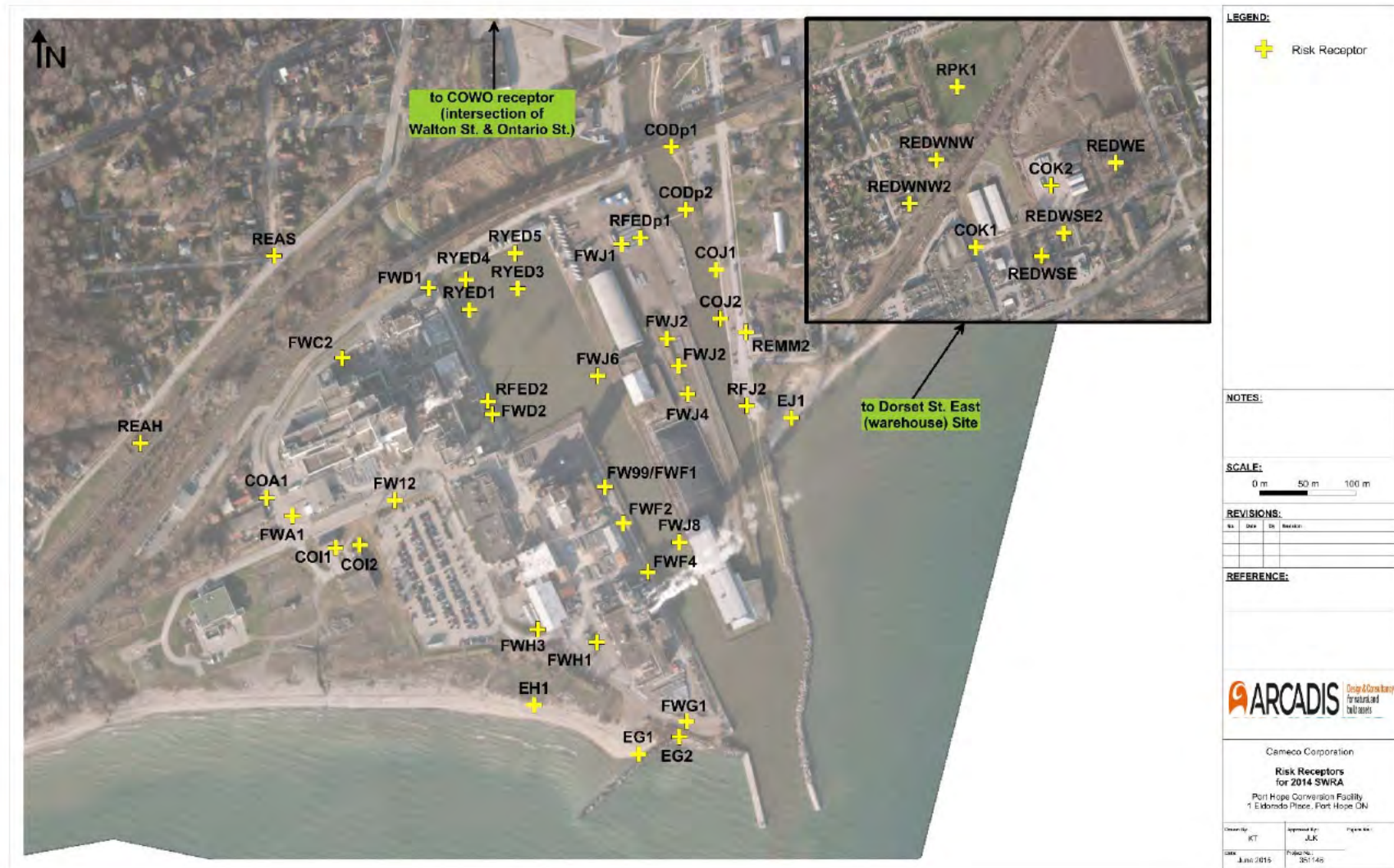

## 5.1.2 Human Health COPCs and Stressors – Secondary Screening

Following from the results of the preliminary screening process (Section 3.0), a human health secondary screening process is carried out to determine which COPCs are relevant to the HHRA, and, to further refine the list of COPCs for risk calculations. Secondary human health screening is conducted for groundwater and soil.

Consistent with the N288.6 (2012) guidance, the secondary screenings (presented later in this report) take into consideration numerous factors when distinguishing between human health and ecological COPCs: component values, statistical analysis, percentage of samples detected, etc.

### 5.1.2.1 COPCs for Groundwater – Human Health

To identify COPCs in groundwater for human receptors, the maximum measured groundwater concentrations were compared to the MOE groundwater components for potable water within 30 m of a water body (MOE 2011). Because the depth to the water table ranges from 1-4.5 mbgs across the site (Golder 2008, SWEIR), the site conditions are considered ‘shallow soil’.

The human health components considered include:

- GW1 – groundwater concentration based on the potential for movement to a human receptor via drinking water; applies to direct contact;
- GW1 Odour – odour threshold for GW1 drinking water component;
- GW2 (Industrial; Shallow Soils) – groundwater concentration based on the potential for volatile COPCs to migrate to indoor industrial air. Note that the GW2 residential component is not considered relevant because it is assumed that any future buildings on the site will not have a basement; and
- GW2 Odour (Industrial) – groundwater concentration that will not result in unacceptable odour.

Since the air concentration as a result of migration of volatile vapours from the groundwater will be less in the outdoor air than the indoor air, any COPC with a maximum concentration that did not exceed either of the GW2 components was also not selected for outdoor air.

It was also assumed that the GW1 component would be protective of dermal exposure and, as such, if a concentration did not exceed the GW1 component, then that COPC was not selected for further assessment of direct contact.

A contaminant was selected as a groundwater COPC for the human health assessment if the maximum measured concentration was above the applicable component, or if no component was available. If no component was available and there was no toxicological information available, then the COPC was dropped from further assessment. All radionuclides were retained as COPCs.

Maximum measured groundwater concentrations are also compared to the Ontario Drinking Water Standard (ODWS) in the table below. While human receptors are not expected to drink the groundwater on-site, this pathway must be considered so that risk management measures to eliminate the possibility of exposure can be implemented. This is discussed further in the text following the table.

Final – Environmental Risk Assessment for the Cameco Port Hope Conversion Facility

Table 5.2 Groundwater: Human Health Secondary Screening of COPCs

Parameter	Units	Maximum Measured Concentration	GW1	GW1 Odour	GW2 (Industrial, Shallow Soils)	GW2 Odour (Industrial)	ODWS	Retained as COPC for Direct Contact Pathways ?	Retained as COPC for Air Pathways ?
-	-	-	Direct Contact	Air	Air	Air	Drinking Water	-	-
Fluoride	mg/L	75	nc	nc	nc	nc	1.5	Yes (a)	No (b)
TDS	mg/L	1.58E+05	nc	nc	nc	nc	500	Yes (a)	No (b)
Chloride	µg/L	8.20E+07	nc	nc	nc	nc	2.50E+05	Yes (a)	No (b)
Nitrate	as N mg/L	115	nc	nc	nc	nc	10	Yes (a)	No (b)
Ammonia (Total)	as N mg/L	150	nc	nc	nc	nc	nc	Yes (a)	Yes (a)
Sulphate	mg/L	1200	nc	nc	nc	nc	500	Yes (a)	No (b)
<b>Metals</b>									
Ag	µg/L	3.00E+01	100	nc	nc	nc	nc	No	No (b)
As	µg/L	1.15E+03	25	nc	nc	nc	nc	Yes	No (b)
Al	µg/L	2.20E+02	nc	nc	nc	nc	100	Yes (a)	No (b)
Ca	µg/L	1.22E+07	nc	nc	nc	nc	nc	Yes (a)	No (b)
Cu	µg/L	290	1000	nc	nc	nc	1000	No	No (b)
Fe	µg/L	36700	nc	nc	nc	nc	300	Yes (a)	No (b)
K	µg/L	1.08E+06	nc	nc	nc	nc	nc	Yes (a)	No (b)
Mg	µg/L	5.19E+06	nc	nc	nc	nc	nc	Yes (a)	No (b)
Mn	µg/L	2600	nc	nc	nc	nc	50	Yes (a)	No (b)
Na	µg/L	2.37E+07	200000	nc	nc	nc	200	Yes	No (b)
Pb	µg/L	20	10	nc	nc	nc	0.01	Yes	No (b)
Se	µg/L	538	10	nc	nc	nc	0.01	Yes	No (b)



Final – Environmental Risk Assessment for the Cameco Port Hope Conversion Facility

Parameter	Units	Maximum Measured Concentration	GW1	GW1 Odour	GW2 (Industrial, Shallow Soils)	GW2 Odour (Industrial)	ODWS	Retained as COPC for Direct Contact Pathways ?	Retained as COPC for Air Pathways ?
-	-	-	Direct Contact	Air	Air	Air	Drinking Water	-	-
Sr	µg/L	1.09E+06	nc	nc	nc	nc	nc	Yes (a)	No (b)
U	µg/L	21000	20	nc	nc	nc	0.02	Yes	No (b)
Zn	µg/L	2200	5000	nc	nc	nc	5	No	No (b)
<b>Radionuclides</b>									
Ra-226	mBq/L	890	nc	nc	nc	nc	nc	Yes (c)	No (b)
<b>PHC</b>									
F1 (C6-C10)	µg/L	587	818	nc	57.7	nc	nc	No	Yes
F2 (C10-C16)	µg/L	4440	301	nc	97.2	nc	nc	Yes	Yes
F3 (C16-C34)	µg/L	1720	1048	nc	Nc	nc	nc	Yes	No (b)
F4 (C34-C50)	µg/L	1120	1104	nc	nc	nc	nc	Yes	No (b)
<b>VOC</b>									
Benzene	µg/L	277	5	859.0	2.77	1.0E+07	5	Yes	Yes
Carbon Tetrachloride	µg/L	1.2	5	1327.4	0.48	1.7E+07	5	No	Yes
Chloroform	µg/L	17	25	6400.0	1.69	6.3E+07	nc	No	Yes
1,1-Dichloroethylene (vinylidene chloride)	µg/L	20.8	14	710.3	1.15	7.4E+06	14	Yes	Yes
cis-1,2-Dichloroethene	µg/L	1020	20	nc	1.15	nc	nc	Yes	Yes

Final – Environmental Risk Assessment for the Cameco Port Hope Conversion Facility

Parameter	Units	Maximum Measured Concentration	GW1	GW1 Odour	GW2 (Industrial, Shallow Soils)	GW2 Odour (Industrial)	ODWS	Retained as COPC for Direct Contact Pathways ?	Retained as COPC for Air Pathways ?
-	-	-	Direct Contact	Air	Air	Air	Drinking Water	-	-
trans-1,2-Dichloroethene	µg/L	28.6	20	174.9	1.15	1.5E+06	nc	Yes	Yes
Ethylene dibromide	µg/L	<1	0.05	7326.0	0.05	1.7E+08	nc	Yes	Yes
Trichloroethylene	µg/L	1800	5	1091.8	1.15	1.4E+07	5	Yes	Yes
Vinyl Chloride	µg/L	613	2	5263.2	0.12	4.4E+07	2	Yes	Yes

Notes:

Ontario Drinking Water Standard (MOE 2006). Includes Maximum Acceptable Concentration (MAC), Interim MAC, Aesthetic Objectives and Operational Guidelines.

**bold** ODWS - aesthetic objective.

*Italics* ODWS - operational guideline (for parameters that if not controlled may negatively affect water treatment, disinfection and distribution).

nc - no component available.

(a) - No component available; COPC carried forward in assessment.

(b) - No component available but contaminant not volatile; therefore, COPC not carried forward in assessment.

(c) - All radionuclides screened in.

Based on the groundwater human health secondary screening shown in Table 5.2, the following COPCs were retained for evaluation of the direct contact with groundwater pathway:

Fluoride
TDS
Chloride
Nitrate
Ammonia (Total)
Sulphate
Al
As
Ca
Fe
K
Mg
Mn
Na
Pb
Se
Sr
U
All radionuclides, including Ra-226
F2 (C10-C16)
F3 (C16-C34)
F4 (C34-C50)
Benzene
1,1-Dichloroethylene (vinylidene chloride)
cis-1,2-Dichloroethene
trans-1,2-Dichloroethene
Ethylenedibromide
Trichloroethylene
Vinyl Chloride

For the inhalation from groundwater pathways, the following COPCs were retained:

Ammonia (Total)
Petroleum Hydrocarbon (PHC) Fraction F1 (C6-C10)
Petroleum Hydrocarbon (PHC) Fraction F2 (C10-C16)
Benzene
Carbon Tetrachloride
Chloroform
1,1-Dichloroethylene (vinylidene chloride)
cis-1,2-Dichloroethene
trans-1,2-Dichloroethene
Ethylenedibromide
Trichloroethylene
Vinyl Chloride

It can be seen from Table 5.2 that several of the maximum measured groundwater concentrations exceed the Ontario Drinking Water Standard, including organic and inorganic COPCs. This is a pathway that can be addressed by prohibiting the use of groundwater on the site as potable drinking water. This risk management measure will eliminate this pathway of exposure (i.e., ingestion of groundwater as drinking water), for all COPCs.

#### 5.1.2.2 COPCs for Soil – Human Health

To identify COPCs in soil for human receptors, the maximum measured soil concentrations from all soil depths were compared to MOE Table 3 components for Industrial/Commercial Land Use (Full Depth, Non-potable water scenario, Coarse-textured soil, MOE 2011).

The human health components considered include:

- S1 – soil concentration based on long-term, high frequency contact via soil ingestion and dermal contact (i.e. toddler park user);
- S2 – soil concentration based on long-term, lower frequency and lower intensity exposure via soil ingestion and dermal contact (i.e., commercial worker);
- S3 – soil concentration based on short-term, high intensity exposure via soil ingestion, dermal contact and inhalation of soil particles (i.e., PHCF sub-surface worker);
- S-IA – soil concentration based on the potential for volatile organics to migrate directly from soil to indoor air and be inhaled by a receptor;
- Indoor Air – soil concentration that will not result in unacceptable odour;

- Outdoor Air – soil concentration based on the potential for volatile organics to migrate directly from soil to outdoor air and be inhaled by a human receptor; and
- Soil Odour (S-nose) – soil concentration based on odour.

The pathway of soil leaching to groundwater (S-GW1) was not included, because contaminant levels in the groundwater are measured directly.

A contaminant was selected as a soil COPC for the human health assessment if the maximum measured concentration was above the applicable component, or if no component was available. If no component was available and there was no toxicological information available, then the COPC was dropped from further assessment. All radionuclides were retained as COPCs.

The identification of soil COPCs for the human health assessment is summarized in Table 5.3.

Final – Environmental Risk Assessment for the Cameco Port Hope Conversion Facility

Table 5.3 Soil: Human Health Secondary Screening of COPCs

Parameter	Units	Max Soil Conc	S1 (Direct Contact)	S2 (Direct Contact)	S3 (Direct Contact & Inhal of Soil Particles)	S-IA	Indoor Air (Odour)	Soil-Odour (S-nose)	Outdoor Air	Retained as COPC for Direct Contact Pathways?	Retained as COPC for Indoor Air Pathways?	Retained as COPC for Outdoor Air Pathways?
Fluoride	µg/g	20400	nc	nc	nc	nc	nc	nc	nc	Yes (a)	No (b)	No (b)
Ammonia (Total)	µg/g	2190	nc	nc	nc	nc	nc	nc	nc	Yes (a)	Yes (a)	Yes (a)
Nitrite	µg/g	11	nc	nc	nc	nc	nc	nc	nc	Yes (a)	No (b)	No (b)
Nitrate	µg/g	1500	nc	nc	nc	nc	nc	nc	nc	Yes (a)	No (b)	No (b)
Bromide	µg/g	490	nc	nc	nc	nc	nc	nc	nc	Yes (a)	No (b)	No (b)
Chloride	µg/g	696	nc	nc	nc	nc	nc	nc	nc	Yes (a)	No (b)	No (b)
Phosphate	µg/g	862	nc	nc	nc	nc	nc	nc	nc	Yes (a)	No (b)	No (b)
Sulphate	µg/g	15100	nc	nc	nc	nc	nc	nc	nc	Yes (a)	No (b)	No (b)
<b>Metals</b>												
Al	µg/g	36300	nc	nc	nc	nc	nc	nc	nc	Yes (a)	No (b)	No (b)
As	µg/g	1790	0.95	1.3	46.8	nc	nc	nc	nc	Yes	No (b)	No (b)
Ba	µg/g	2020	3756.57	31508.5	8573.8	nc	nc	nc	nc	No	No (b)	No (b)
B (Total)	µg/g	1790	nc	nc	nc	nc	nc	nc	nc	Yes (a)	No (b)	No (b)
Cd	µg/g	9.8	nc	nc	nc	nc	nc	nc	nc	Yes (a)	No (b)	No (b)
Co	µg/g	2730	nc	nc	nc	nc	nc	nc	nc	Yes (a)	No (b)	No (b)
Cu	µg/g	8830	599.09	5639.3	5639.3	nc	nc	nc	nc	Yes	No (b)	No (b)
Fe	µg/g	180000	nc	nc	nc	nc	nc	nc	nc	Yes (a)	No (b)	No (b)
K	µg/g	45000	nc	nc	nc	nc	nc	nc	nc	Yes (a)	No (b)	No (b)
Mg	µg/g	84300	nc	nc	nc	nc	nc	nc	nc	Yes (a)	No (b)	No (b)
Mn	µg/g	3600	nc	nc	nc	nc	nc	nc	nc	Yes (a)	No (b)	No (b)
Ni	µg/g	5690	327.06	2243.0	514.4	nc	nc	nc	nc	Yes	No (b)	No (b)
Pb	µg/g	30000	200.00	1000.0	1000.0	nc	nc	nc	nc	Yes	No (b)	No (b)
Se	µg/g	16	108.41	1239.1	1239.1	nc	nc	nc	nc	No	No (b)	No (b)

Final – Environmental Risk Assessment for the Cameco Port Hope Conversion Facility

Parameter	Units	Max Soil Conc	S1 (Direct Contact)	S2 (Direct Contact)	S3 (Direct Contact & Inhal of Soil Particles)	S-JA	Indoor Air (Odour)	Soil-Odour (S-nose)	Outdoor Air	Retained as COPC for Direct Contact Pathways?	Retained as COPC for Indoor Air Pathways?	Retained as COPC for Outdoor Air Pathways?
Sb	µg/g	166	7.51	63.0	63.0	nc	nc	nc	nc	Yes	No (b)	No (b)
Sr	µg/g	3000	nc	nc	nc	nc	nc	nc	nc	Yes (a)	No (b)	No (b)
U	µg/g	16800	23.00	300.0	300.0	nc	nc	nc	nc	Yes	No (b)	No (b)
V	µg/g	150	39.44	164.2	164.2	nc	nc	nc	nc	Yes	No (b)	No (b)
Zn	µg/g	5500	5634.85	47262.8	47262.8	nc	nc	nc	nc	No	No (b)	No (b)
<b>Radionuclides</b>												
Ra-226	Bq/g	32	nc	nc	nc	nc	nc	nc	nc	Yes (c)	No (b)	No (b)
<b>PHC</b>												
F1 (C6-C10)	µg/g	245	6859.56	47042.4	103078.2	583.5	nc	nc	25754.6	No	No	No
F2 (C10-C16)	µg/g	3200	3144.84	21567.1	48340.1	375.9	nc	nc	24765.1	Yes	Yes	No
F3 (C16-C34)	µg/g	140000	5785.32	39675.4	262849.4	nc	nc	nc	nc	Yes	No (b)	No (b)
<b>PCB</b>												
PCBs (Total)	µg/g	12	0.35	2.7	4.1	44.7	nc	nc	120.8	Yes	No	No

Notes:

- (a) - No component available; COPC carried forward in assessment.
- (b) - No component available but contaminant not volatile; therefore, COPC not carried forward in assessment.
- (c) - All radionuclides screened in.

As seen in the above table, the following COPCs were retained for evaluation of the direct contact with soil pathway:

Fluoride
Ammonia (Total)
Nitrite
Nitrate
Bromide
Chloride
Phosphate
Sulphate
Al
As
B (Total)
Cd
Co
Cu
Fe
K
Mg
Mn
Ni
Pb
Sb
Sr
U
V
Radionuclides, including Ra-226
Petroleum Hydrocarbon (PHC) Fraction F2 (C10-C16)
Petroleum Hydrocarbon (PHC) Fraction F3 (C16-C34)
PCBs (Total)



For the inhalation from soil pathways, the following COPCs were retained:

- (a) For indoor air pathways: Ammonia (total) and Petroleum Hydrocarbon F2 Fraction (C10-C16); and
- (b) For outdoor air pathways: Ammonia (total).

As seen in the table above, there was no component value for ammonia to indoor air. The maximum measured concentration of PHC F2 in soil is higher than the S-IA component, indicating that exposure to volatiles inside a building is a potential concern for receptors. This is a pathway that needs to be addressed.

### 5.1.2.3 Overall List of COPCs for HHRA

Based on the primary surface water screening and the secondary groundwater and soil screening conducted in the above sections, the following COPCs have been selected for the HHRA.

Table 5.4 Overall List of COPCs for HHRA

COPC	Pathways to be assessed					
	GW Direct Contact	GW Air	Soil Direct Contact	Soil Indoor Air	Soil Outdoor Air	Surface Water
Fluoride	✓		✓			✓
Nitrite			✓			
Nitrate	✓		✓			
Ammonia (Total)	✓	✓	✓	✓	✓	✓
Ammonia (un-ionized)						✓
Bromide			✓			
Chloride	✓		✓			✓
Phosphate			✓			
Sulphate	✓		✓			
TDS	✓					
Al	✓		✓			✓
As	✓		✓			✓
B (total)			✓			
Ca	✓					
Cd			✓			
Co			✓			
Cu			✓			
Fe	✓		✓			
K	✓		✓			✓

Final – Environmental Risk Assessment for the Cameco Port Hope Conversion Facility

COPC	Pathways to be assessed					
	GW Direct Contact	GW Air	Soil Direct Contact	Soil Indoor Air	Soil Outdoor Air	Surface Water
Mg	✓		✓			
Mn	✓		✓			
Na	✓					
Ni			✓			
P						✓
Pb	✓		✓			
Sb			✓			
Se	✓					
Sr	✓		✓			✓
U	✓		✓			✓
V			✓			
Zn						✓
Radionuclides (all)	✓		✓			✓
Benzene	✓	✓				
Carbon Tetrachloride		✓				
Chloroform		✓				
Dichlorodifluoromethane						✓
1,1-Dichloroethylene	✓	✓				
cis-1,2-Dichloroethene	✓	✓				
trans-1,2-Dichloroethene	✓	✓				
Ethylenedibromide	✓	✓				
Trichloroethylene	✓	✓				
Vinyl Chloride	✓	✓				
F1 (C6-C10)		✓				
F2 (C10-C16)	✓	✓	✓	✓		
F3 (C16-C34)	✓		✓			
F4 (C34-C50)	✓					
PCBs (Total)			✓			

### 5.1.3 HHRA Exposure Pathways

The next step is to examine the potential pathways of exposure and identify the ways in which human receptors could be exposed to COPCs and radiological stressors present in the different environmental media, as identified in Sections 3.0 (preliminary COPC identification) and 5.1.2 (secondary HHRA COPC identification).

In general, human receptors may come into contact with contaminants through four primary exposure routes: dermal exposure, incidental ingestion (of for example, soil), ingestion of contaminated food, and inhalation (though inhalation is likely to be minimal in comparison to other pathways, since all exposures occur outdoors). Therefore, an exposure pathway consists of a contaminant source, a release mechanism, one or more transport mechanisms, a point of exposure (receptor), and an exposure route for intake into the human body.

For direct gamma and other external radiation, exposure can occur externally without one of the four primary exposure routes. As a result, external radiation dose rates are included in this HHRA.

Under CSA N288.6 (2012), HHRAs apply to off-site receptors (i.e., members of the public) and on-site non-nuclear energy workers (non-NEWs) that are not covered under the facility's radiation protection program or health and safety program. At the PHCF and Dorset Street facilities, all of the workers who conduct work outside of an office area are trained as NEWs. Maintenance workers are NEWs, as are contractors who are performing work in production areas (Cameco 2015a). Therefore, for the purposes of this HHRA, human receptors are categorized into the following groups:

- Nearby resident (multiple locations and age variants; also compounded with any of the receptors below for conservative estimates of dose);
- Recreational fisherperson;
- Recreational boater/ yacht club user;
- Recreational park user;
- Recreational fenceline walker; and
- Commercial (non-Cameco) worker (multiple locations).

#### 5.1.3.1 Soil Exposure Pathways

Based on the types of receptors, their characteristics, and their behaviours as described in Section 5.1.1, human receptors may come into contact with soil, resulting in the following potential soil exposures:

- Dermal exposure to soil;
- Incidental ingestion of soil;
- External exposure (radiological only) to ground deposits; and
- Inhalation of indoor vapours from soil.

Inhalation of outdoor vapours from soil have been excluded since vapours would disperse in outdoor air and none of the identified receptors are located in trenches or confined spaces where outdoor vapours could accumulate.

Detailed breakdowns of soil exposure pathways are presented in Table 5.5.

#### 5.1.3.2 Groundwater Exposure Pathways

Hypothetically, human receptors could come into contact with contaminated groundwater resulting in the following groundwater exposures:

- Dermal exposure to groundwater;
- Incidental ingestion of groundwater; and,
- Inhalation of indoor vapours from groundwater.

However, residents of Port Hope obtain their drinking water supply from a municipal system. No water supply wells (i.e., drinking water wells) have been identified on-site or off-site that may be affected by contamination (SENES 2009a). The site is regarded as a non-potable groundwater condition. Therefore, ingesting of groundwater as drinking water is excluded. Similarly, as there is no opportunity for members of the public to have dermal exposure to groundwater, this pathway is also excluded.

Inhalation of outdoor vapours from groundwater have been excluded since vapours would disperse in outdoor air, and none of the identified receptors are located in trenches or confined spaces where outdoor vapours could accumulate.

Therefore, groundwater exposure pathways for members of the public are not discussed further in this study.

#### 5.1.3.3 Air Exposure Pathways

The pathway of inhalation of outdoor air is included. For the members of the public, located off of the PHCF and Dorset Street sites, air concentrations of uranium were modelled (See Section 3.1).

#### 5.1.3.4 Surface Water Exposure Pathways

Based on the type of receptors, their characteristics, and their behaviours as described in Section 5.1.1, certain (though not all) human receptors may come into contact with contaminated surface water, resulting in the following surface water exposures:

- Dermal exposure to surface water while swimming;
- Incidental ingestion of surface water while swimming;
- Dermal exposure to surface water due to falling into the harbour; and
- Incidental ingestion of surface water due to falling into the harbour.

It is important to note that residents of Port Hope obtain their drinking water supply from a municipal system; untreated surface water is not ingested as drinking water. Therefore, ingestion of surface water as drinking water is excluded.

#### 5.1.3.5 Contaminated Food Exposure Pathways

Based on their characteristics and behaviour as described in Section 5.2.2 (see Table 5.8), off-site receptors (members of the public), may come into contact with contaminated foods resulting in the following exposures:

- Consumption of fish caught from the Port Hope Harbour (and resulting ingestion of surface water COPCs taken up by the fish); and
- Consumption of garden produce grown in off-site soil (and resulting ingestion of off-site soil COPCs taken up by the vegetation).

As described in Section 5.2.2 (see Table 5.8), locally-obtained fish and garden produce comprise only a small portion of the total dietary intake of the off-site human receptor (member of the public).

#### 5.1.3.6 Sediment Exposure Pathways

Based on the type of receptors, their characteristics, and their behaviours as described in Section 5.1.1, no human receptors are expected to come into contact with contaminated sediments. Public receptors swimming at the beach would not likely have contact with sediment at the bottom of Lake Ontario. Similarly, boaters who fall off their boat are unlikely to have contact with the sediment at the bottom of the Harbour. In addition, sediment washes off quickly; it does not adhere to skin. Therefore, sediment pathways for human receptors are not considered in the HHRA.

#### 5.1.3.7 Gamma Radiation Exposure Pathway

Based on the characteristics and behaviour as described in Section 5.1.1, off-site receptors (i.e., members of the public) that are present near the PHCF or Dorset Street may experience external gamma exposure.

Gamma radiation doses for off-site public receptors are assessed in the HHRA based on direct external gamma radiation exposure. [REDACTED]

#### 5.1.3.8 External Radiation Exposure

Based on the characteristics and behaviour as described in Section 5.1.1, select off-site receptors (members of the public) could potentially receive a radiological external dose from the following pathways, depending on the activities they engage in:

- Immersion in surface water (from swimming, or, falling into the harbor); and,
- Direct gamma radiation (as discussed in Section 5.1.3.7).

#### 5.1.3.9 Summary of Inactive/Non-Applicable Exposure Pathways

Based on the receptor descriptions and the defined activities they engage in, the following exposure pathways are not applicable:

##### External Exposure from Immersion in air (Radiological)

In many cases immersion in air is not a dominant contributor to overall radiological dose. The external dose contributed by air immersion is typically low enough to be neglected; only when specific conditions exist - such as confined spaces (where radionuclide levels can accumulate) or elevated concentrations of radionuclides in air – does the dose contribution from air immersion increase and warrant consideration. Furthermore, air COPC screening shows that air concentrations are below their corresponding criteria. Therefore, external dose from air immersion can be excluded from further assessment.

##### Inhalation of Outdoor Groundwater Vapours

Inhalation of outdoor vapours from groundwater have been excluded since vapours would disperse in outdoor air and none of the identified receptors are located in trenches or confined spaces where outdoor vapours could accumulate.

##### Inhalation of Outdoor Soil Vapours

Similarly, inhalation of outdoor vapours from soil have been excluded since vapours would disperse in outdoor air and none of the identified receptors are located in trenches or confined spaces where outdoor vapours could accumulate.

##### Ingestion of Groundwater or Surface Water COPCs as Drinking Water

Drinking water usage was investigated as part of the SENES (2009a) SWRA. It was determined that no drinking water wells exist in the study area, and that nearby human receptors obtain their drinking water from the municipal system, and not directly from surface water in the Harbour (or near the facility shoreline) or from groundwater within the study area. Therefore, drinking water intake can be excluded from further assessment.

##### Sediment Exposure Pathways

Based on the type of receptors, their characteristics, and their behaviours as described in Section 5.1.1, no human receptors are expected to come into contact with contaminated sediments. Public receptors swimming at the beach would not likely have contact with sediment at the bottom of Lake Ontario. Similarly, boaters who fall off their boat are unlikely to have contact with the sediment at the bottom of the Harbour. In

addition, sediment washes off quickly; it does not adhere to skin. Therefore, sediment pathways for human receptors are not considered in the HHRA.

*Inhalation of Soil Particulate/Dust*

Off-site member of the public receptors are not assessed for soil particulate/dust inhalation as part of their activities; they *are* assessed for inhalation of outdoor air (based on modelled concentrations from PHCF emissions).

5.1.3.10 Summary of Active HHRA Exposure Pathways

Exposure pathways related to each environmental medium (soil, groundwater, surface water, and sediment) are described in their respective sections above. An overall summary of exposure pathways for the member of the public receptors is presented in Table 5.5.

Table 5.5 HHRA Exposure Pathways Summary – Off-Site Public Receptors

Pathway	OFF-SITE HUMAN RECEPTORS							
	Nearby Resident			Recreational Fishperson	Recreational Boater/ Yacht Club User	Fenceline Walker	Recreational Park User	Commercial Worker
	Infant	Toddler, Child, Teen	Adult	Adult	Adult	Adult	All ages	Adult
Assumed Exposure Type	Long Term	Long Term	Long Term	Long Term	Long-Term	Long-Term	Long-Term	Long-Term
Dermal contact with soil	Y	Y	Y	N <i>(no such activities)</i>	N <i>(Not working with soil)</i>	N <i>(Not working with soil)</i>	Y	N <i>(Not working with soil)</i>
Dermal contact with groundwater (inside or outside of buildings)	N <i>(No contact with GW)</i>	N <i>(No contact with GW)</i>	N <i>(No contact with GW)</i>	N <i>(No contact with GW)</i>	N <i>(Not working with GW; no GW contact)</i>	N <i>(Not working with GW; no GW contact)</i>	N <i>(No contact with GW)</i>	N <i>(Not working with GW; no GW contact)</i>
Dust inhalation	N <i>(On-site workers only)</i>	N <i>(On-site workers only)</i>	N <i>(On-site workers only)</i>	N <i>(On-site workers only)</i>	N <i>(On-site workers only)</i>	N <i>(On-site workers only)</i>	N <i>(On-site workers only)</i>	N <i>(On-site workers only)</i>
Incidental ingestion of soil	Y	Y	Y	N <i>(Not engaged in soil-related activities)</i>	N <i>(Not engaged in soil-related activities)</i>	N <i>(Not engaged in soil-related activities)</i>	Y	N <i>(Not engaged in soil-related activities)</i>
Inhalation of outdoor air	Y <i>(U considered for completeness, though air COPCs screened out)</i>	Y <i>(U considered for completeness, though air COPCs screened out)</i>	Y <i>(U considered for completeness, though air COPCs screened out)</i>	Y <i>(U considered for completeness, though air COPCs screened out)</i>	Y <i>(U considered for completeness, though air COPCs screened out)</i>	Y <i>(U considered for completeness, though air COPCs screened out)</i>	Y <i>(U considered for completeness, though air COPCs screened out)</i>	Y <i>(U considered for completeness, though air COPCs screened out)</i>
Inhalation of vapours from soil (to open air)	N <i>(No volatile COPCs in off-site soil)*</i>	N <i>(No volatile COPCs in off-site soil)*</i>	N <i>(No volatile COPCs in off-site soil)*</i>	N <i>(No volatile COPCs in off-site soil)*</i>	N <i>(No volatile COPCs identified in off-site soil*)</i>	N <i>(No volatile COPCs identified in off-site soil*)</i>	N <i>(No volatile COPCs in off-site soil)*</i>	N <i>(No volatile COPCs identified in off-site soil*)</i>
Inhalation of vapours from soil (to indoor air)	N <i>(No volatile COPCs in off-site soil)*</i>	N <i>(No volatile COPCs in off-site soil)*</i>	N <i>(No volatile COPCs in off-site soil)*</i>	N <i>(Outdoor receptor; no volatile COPCs in off-site soil)*</i>	N <i>(No volatile COPCs identified in off-site soil*)</i>	N <i>(No volatile COPCs identified in off-site soil*)</i>	N <i>(Outdoor receptor; no volatile COPCs in off-site soil)*</i>	N <i>(No volatile COPCs identified in off-site soil*)</i>
Inhalation of vapour from groundwater (to open air)	N <i>(Off-site GW not the focus of this study)</i>	N <i>(Off-site GW not the focus of this study)</i>	N <i>(Off-site GW not the focus of this study)</i>	N <i>(Off-site GW not the focus of this study)</i>	N <i>(Off-site GW not the focus of this study)</i>	N <i>(Off-site GW not the focus of this study)</i>	N <i>(Off-site GW not the focus of this study)</i>	N <i>(Off-site GW not the focus of this study)</i>
Inhalation of vapour from groundwater (to indoor air)	N <i>(Off-site GW not the focus of this study)</i>	N <i>(Off-site GW not the focus of this study)</i>	N <i>(Off-site GW not the focus of this study)</i>	N <i>(Off-site GW not the focus of this study)</i>	N <i>(Off-site GW not the focus of this study)</i>	N <i>(Off-site GW not the focus of this study)</i>	N <i>(Off-site GW not the focus of this study)</i>	N <i>(Off-site GW not the focus of this study)</i>
Incidental ingestion of groundwater (inside or outside of buildings)	N <i>(Off-site GW not the focus of this study)</i>	N <i>(Off-site GW not the focus of this study)</i>	N <i>(Off-site GW not the focus of this study)</i>	N <i>(Off-site GW not the focus of this study)</i>	N <i>(Off-site GW not the focus of this study)</i>	N <i>(Off-site GW not the focus of this study)</i>	N <i>(Off-site GW not the focus of this study)</i>	N <i>(Off-site GW not the focus of this study)</i>



Final – Environmental Risk Assessment for the Cameco Port Hope Conversion Facility

Pathway	OFF-SITE HUMAN RECEPTORS							
	Nearby Resident			Recreational Fisherman	Recreational Boater/ Yacht Club User	Fenceline Walker	Recreational Park User	Commercial Worker
	Infant	Toddler, Child, Teen	Adult	Adult	Adult	Adult	All ages	Adult
Drinking water intake	N <i>(DW obtained from municipal supply, not GW or SW)</i>	N <i>(DW obtained from municipal supply, not GW or SW)</i>	N <i>(DW obtained from municipal supply, not GW or SW)</i>	N <i>(DW obtained from municipal supply, not GW or SW)</i>	N <i>(DW obtained from municipal supply, not GW or SW)</i>	N <i>(DW obtained from municipal supply, not GW or SW)</i>	N <i>(DW obtained from municipal supply, not GW or SW)</i>	N <i>(DW obtained from municipal supply, not GW or SW)</i>
Dermal exposure to surface water while swimming at the beach	Y	Y	Y	N <i>(no swimming activities)</i>	N <i>(no swimming activities)</i>	N <i>(no swimming activities)</i>	N <i>(no swimming activities)</i>	N <i>(no swimming activities)</i>
Incidental ingestion of surface water while swimming at the beach	Y	Y	Y	N <i>(no swimming activities)</i>	N <i>(no swimming activities)</i>	N <i>(no swimming activities)</i>	N <i>(no swimming activities)</i>	N <i>(no swimming activities)</i>
Dermal exposure to surface water when fall off boat in Harbour	N <i>(unlikely to be in a location where they could fall into the harbour)</i>	Y	Y	N <i>(Assessed via other receptors)</i>	Y	N <i>(not located on boat, or along harbour wall)</i>	N	N <i>(not located on boat, or along harbour wall)</i>
Incidental ingestion of surface water when fall off boat in Harbour	N <i>(unlikely to be in a location where they could fall into the harbour)</i>	Y	Y	N <i>(Assessed via other receptors)</i>	Y	N <i>(not located on boat, or along harbour wall)</i>	N	N <i>(not located on boat, or along harbour wall)</i>
Incidental ingestion of sediment	N	N	N	N	N	N	N	N
Ingestion of local fish (caught near Centre Pier)	N <i>(Infant diet does not include local fish)</i>	Y	Y	Y	N <i>(no fishing and fish consumption)</i>	N <i>(no fishing and fish consumption)</i>	N <i>(no fishing and fish consumption)</i>	N <i>(not a resident, not engaged in fishing and consumption of locally caught fish)</i>
Ingestion of produce (grown locally, in off-site soil)	N <i>(Infant diet does not include local produce)</i>	Y	Y	N <i>(not a local resident, no consumption of garden produce)</i>	N <i>(not a local resident, no consumption of garden produce)</i>	N <i>(not a local resident, no consumption of garden produce)</i>	N	N <i>(not a local resident, therefore no consumption of garden produce)</i>
External exposure from immersion in surface water (radiological)	Y	Y	Y	N <i>(no swimming activities)</i>	N <i>(no swimming activities)</i>	N <i>(no swimming activities)</i>	N	N <i>(no swimming activities)</i>
External exposure from immersion in air (radiological)	N	N	N	N	N	N	Y	N
External exposure from soil deposits (radiological)	N*	N*	N*	N*	N*	N*	N*	N*
Direct gamma (radiological)	Y	Y	Y	Y	Y	Y	Y	Y

Notes:

\* Assessment of off-site soil is limited to uranium, as it alone is related to site operations (via air emissions and deposition to off-site soil).

DW – Drinking water, GW – Groundwater, SW – Surface water.

#### **5.1.4 HHRA Conceptual Site Model (CSM)**

The overall HHRA study boundaries are based on knowledge of the site and surrounding area, and includes a range of known and potential contamination sources. However, it is important to note that multiple documented sources of contamination exist, both on-site and off-site, and many are not related to current operations at the PHCF (e.g., on-site historical contamination). As such, many different sources contribute to the levels of contaminants identified in environmental media (see Sections 3.0 and 5.1.2 for identification of COPCs). This risk assessment focuses on receptors and pathways relevant to current operations at the PHCF; as indicated in Figure 5.2, it does not focus on off-site and historical sources of contamination.

Figure 5.2 outlines the many environmental media included in this study, along with the exposure pathways that link these environmental media to human receptors.

Figure 5.3 presents a graphical conceptual site model, based on the known COPCs and their locations, identified receptors, and relevant exposure pathways.

#### **5.1.5 Tiered Approach to HHRA**

The HHRA was carried out using a tiered approach, as follows. All receptor-COPC combinations were assessed at a Tier 1 screening level, using conservative assumptions about environmental concentrations, human receptor characteristics and risk assessment parameters. For receptor-COPC combinations with exceedances at a Tier 1 level, Tier 2 HHRA calculations were carried out, using more realistic concentrations and parameters.

Figure 5.2. On-Site & Off-Site Sources of Contamination and Interactions

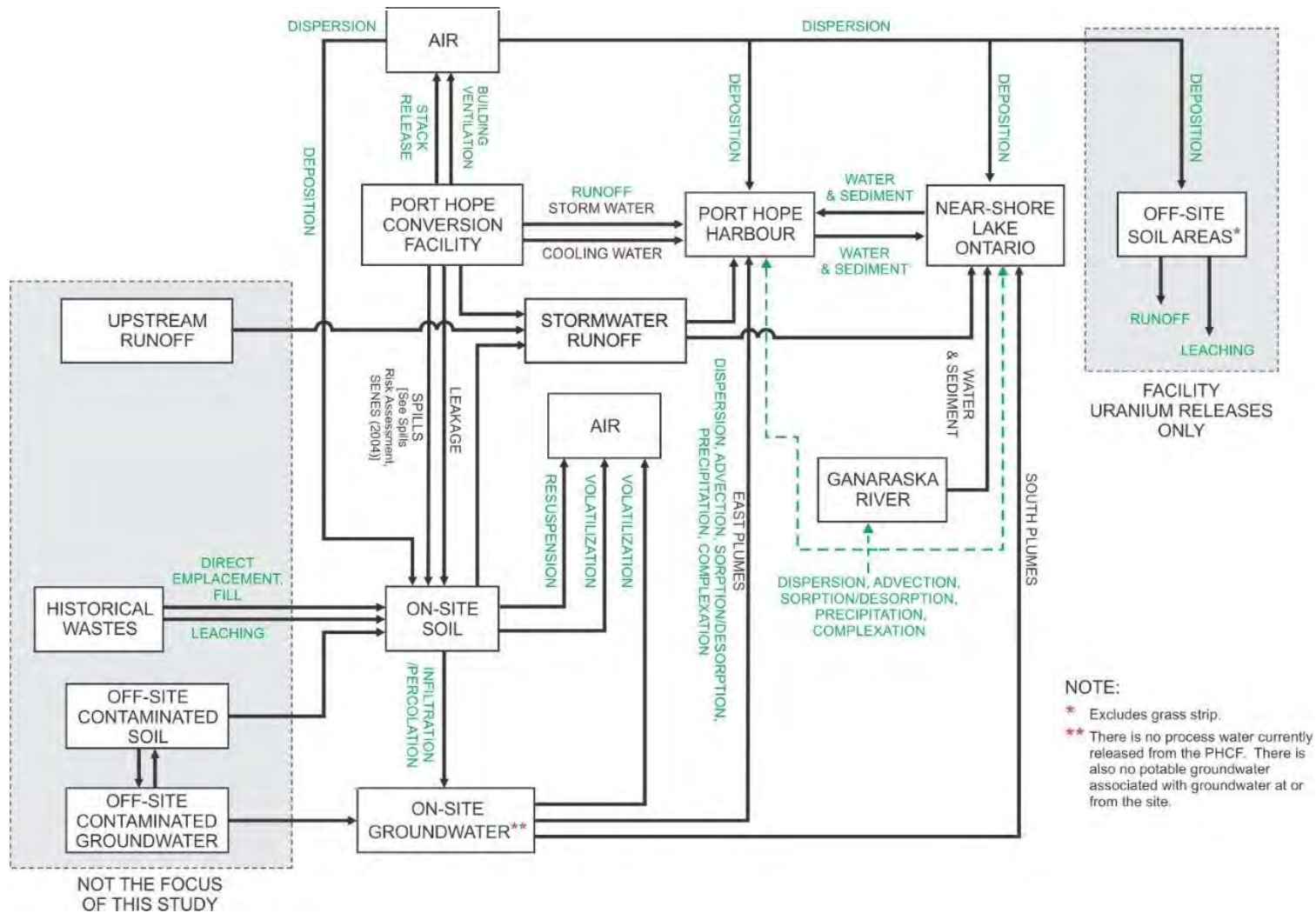
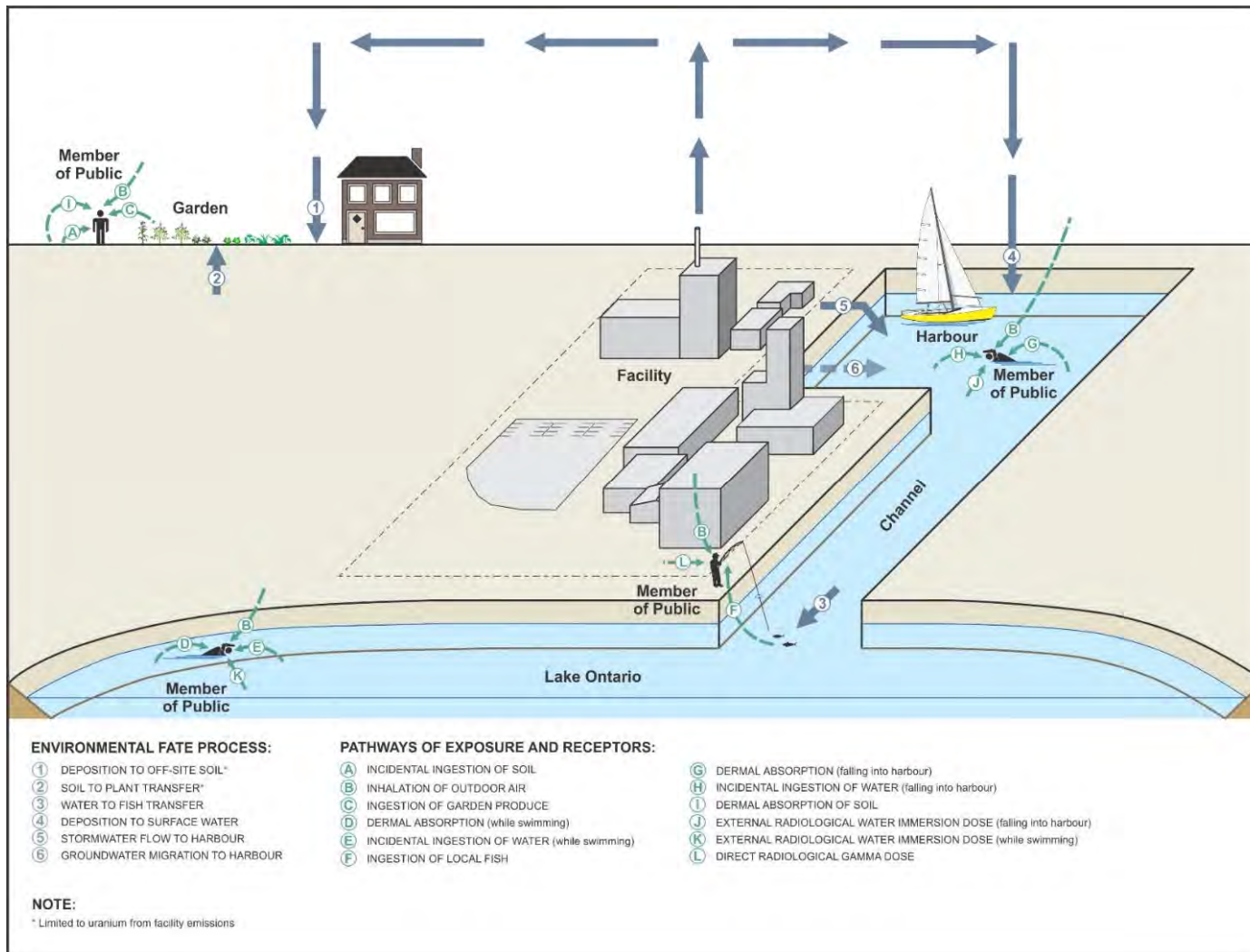

Figure 5.3. HHRA Conceptual Site Model – Off-Site Member of the Public Receptors



Problem Formulation Checklist

Table 5.6 presents the problem formulation checklist for the HHRA, consistent with CSA (2012).

Table 5.6 HHRA – Problem Formulation Checklist

**a) Land Use**

Land Use		
X	<i>Agricultural</i>	No agricultural land use identified within study area.
✓	<i>Residential</i>	Facility site and immediately adjacent land is industrial, though residential lands are located nearby. Pathways included for nearby residents.
✓	<i>Commercial</i>	No commercial land is identified within the site or immediately adjacent lands. Pathways included for commercial worker receptors.
✓	<i>Industrial</i>	Facility site and immediately adjacent lands identified as industrial.
✓	<i>Parkland</i>	For the PHCF and Dorset Street sites, no parkland is identified within or immediately adjacent to the facility site. However, the HHRA does evaluate public receptors who may use the parks or other recreational use areas located around the facilities.

**b) Receptor Groups**

Receptor Groups		
✓	<i>Public</i>	Members of the public, including nearby residents, are represented in the study.
X	<i>Employees</i>	Facility workers are not included in the study, as they are all considered NEWs (see discussion in Section 5.1.1).
X	<i>Construction</i>	On-site construction worker receptors not included in the study, as contractors performing work on the site are trained as NEWs (see discussion in Section 5.1.1).
X	<i>First Nations</i>	No First Nations identified within study area.

**c) Critical Receptors**

Critical Receptors		
✓	<i>Infant</i>	Of the identified public receptors, the nearby resident receptor includes all 5 of the recommended age groups for non-radiological assessment and all 3 recommended age groups for radiological assessment.
✓	<i>Toddler</i>	
✓	<i>Child</i>	
✓	<i>Teen</i>	
✓	<i>Adult</i>	

**d) Exposure Pathways**

Exposure Pathways		
✓	<i>Incidental Soil Ingestion</i>	Included for select public receptors.
✓	<i>Soil dermal absorption</i>	Included for select public receptors.
X	<i>Soil dust inhalation</i>	Not included. Residential receptors assumed to inhale outdoor air, not dust.
X	<i>Soil vapour inhalation</i>	Not included. Public receptors are not exposed to on-site soils.
X	<i>Groundwater incidental ingestion</i>	Not included. Public receptors are not exposed to on-site groundwater.
X	<i>Groundwater dermal absorption</i>	Not included. Public receptors are not exposed to on-site groundwater.
X	<i>Groundwater vapour inhalation</i>	Not included. Public receptors are not exposed to on-site groundwater.
X	<i>Drinking water ingestion</i>	Drinking water for public receptors is obtained from municipal drinking water system, not directly from groundwater or surface water.
✓	<i>Surface water incidental ingestion</i>	Included for public receptors.
✓	<i>Surface water dermal absorption</i>	Included for public receptors.
✓	<i>Ingestion of local fish</i>	Included for public receptors.
✓	<i>Ingestion of garden produce</i>	Included for public receptors.
X	<i>Ingestion of wild game</i>	Not included. Typical wild game (e.g., deer, moose, etc.) not located on lands within or immediately adjacent to the facility.
X	<i>Sediment incidental ingestion</i>	Public receptors not exposed to sediments in the harbour.
X	<i>Sediment dermal absorption</i>	Public receptors not exposed to sediments in the harbour.
✓	<i>Air inhalation</i>	Included for public receptors for completeness, though air screening identified no COPCs that exceed their corresponding air criteria.
X	<i>External soil rad.</i>	Not included. Public receptors are not exposed to on-site soils.
✓	<i>External surface water rad.</i>	Included for public receptors that may swim at nearby beach and for receptors assessed for falling into the harbour.
X	<i>External air rad.</i>	Not included. Air screening identified no radionuclides that exceed their corresponding air criteria; therefore, this pathway has been excluded. See rationale (discussed earlier).
✓	<i>Direct gamma rad.</i>	Included for public receptors.

## 5.2 Exposure Assessment

### 5.2.1 Exposure Locations

As shown in Figure 5.1, human receptors have been assessed at multiple locations around Port Hope. The environmental media that a given receptor is exposed to differs based on their location as well as the “Tier” or level of assessment (discussed in Section 5.1).

Table 5.7 provides a tabular outline of each human receptor, the assessment areas they are associated with, and the corresponding environmental media they may be exposed to, based on the descriptions of the receptors and their behaviours presented in Table 5.1.

Table 5.7 Human Receptor Exposure Locations and Environmental Media

Potential Environmental Media	Exposure Location Description	Resulting Exposure
Soil	<p>Based on their descriptions and behaviours, off-site member of the public receptors could potentially be exposed to residential yard soil or park soil.</p> <p><i>Note that access to the site is controlled. Members of the public cannot enter the site and consequently be exposed to on-site soil.</i></p>	<p><b>Residential Yard Soil</b> (resident)</p> <p><b>Park Soil</b> (recreational park user)</p>
Groundwater	<p>Off-site member of the public receptors are not exposed to on-site groundwater, due to controlled access to the PHCF site. Exposure to off-site groundwater (i.e., not associated with the PHCF site) is not the focus of this study.</p>	-
Surface Water	<p>Based on their descriptions and behaviours, off-site member of the public receptors could potentially be exposed to:</p> <ul style="list-style-type: none"> <li>• Surface water from the Port Hope Harbour when falling into the harbour; and,</li> <li>• Surface water from the nearby beach when swimming.</li> </ul> <p><i>Note that human receptors do not swim in the Port Hope Harbour adjacent to the PHCF.</i></p>	<p><b>Harbour Surface Water</b> (falling)</p> <p><b>Beach Surface Water</b> (swimming)</p>
Sediment	<p>Off-site public receptors are not exposed to contaminated Harbour sediments as part of their activities.</p>	-
Garden Produce	<p>As part of their descriptions and behaviours, off-site member of the public receptors could potentially be exposed to contaminants via ingestion of garden produce grown in residential soil.</p>	<p><b>Garden Produce</b> (estimated based on residential yard soil)</p>

Potential Environmental Media	Exposure Location Description	Resulting Exposure
Local Fish	As part of their descriptions and behaviours, off-site member of the public receptors could potentially be exposed to contaminants via ingestion of fish caught from the Harbour.	<b>Local Fish</b> (estimated based on Harbour surface water)
Outdoor Air	As part of their behaviours, off-site member of the public receptors could potentially be exposed to contaminants via inhalation of outdoor air.	<b>Outdoor Air</b> (Based on off-site soil concentrations – measured and/or estimated)



## **5.2.2 Exposure Factors, Durations & Frequencies**

Table 5.8 presents the exposure factors and exposure durations for the public receptors.

These factors were selected to provide a conservative representation of the situation expected.

Final – Environmental Risk Assessment for the Cameco Port Hope Conversion Facility

Table 5.8 HHRA Exposure Factors & Durations – Off-Site Public Receptors

(Nearby Resident, Recreational Fisherman, Recreational Boater, Recreational Park User, Fenceline Walker, Commercial Worker)

a) Exposure Factors – Non-Radiological (HC 2010, unless otherwise noted)

Age Group <sup>a</sup>	Infant	Toddler	Child	Teen	Adult
Age	0-6 months	7 months – 4 years	5-11 years	12-19 years	≥ 20 years
Age group duration (yrs)	0.5	4-5	7	8	61
Body weight (kg)	8.2	16.5	32.9	59.7	70.7
Inhalation Rate (m <sup>3</sup> /d)	2.2	8.3	14.5	15.6	16.6
Incidental Water Ingestion Rate while swimming (L/h), IR <sub>swim</sub> <sup>b</sup>	0.05	0.05	0.05	0.05	0.05
Incidental Water Ingestion Rate - fall off boat into Harbour (L/h), IR <sub>fall</sub> <sup>b</sup>	0.05	0.05	0.05	0.05	0.05
Total Fish Ingestion Rate <sup>c</sup> (g/d)	0	56	90	104	111
Fraction local (fish)	0.1	0.1	0.1	0.1	0.1
Local Fish Ingestion Rate (g/d)	0	5.6	9	10.4	11.1
Food (produce) Ingestion (g/d) <sup>d</sup>	0	172	259	347	325
Fraction local (produce) <sup>e</sup>	0	0.25	0.25	0.25	0.25
Exposed skin surface area - swimming or fall in (cm <sup>2</sup> )	3,620	6,130	10,140	15,470	17,640
Incidental Soil Ingestion Rate (g/d)	0.02	0.08	0.02	0.02	0.02
Soil Loading (g/cm <sup>2</sup> /event)	0.0001	0.0001	0.0001	0.0001	0.001
Dermal event, ev/d	1	1	1	1	1

Notes:

<sup>a</sup> In the radiological assessment, three age groups were considered based on CSA (2014); these age groups correspond to the Infant, Child and Adult age groups presented above.

<sup>b</sup> Water ingestion rate while swimming: 0.05 L/hr from U.S. EPA 1989 (value for non-competitive swimming).

<sup>c</sup> HC (2012) PQRA Guidance.

<sup>d</sup> HC (2012) PQRA Guidance, values for root vegetables plus other vegetables.

<sup>e</sup> Consistent with CSA (2014) N288.1 local produce fraction, used in radiological calculations. Assumed 0 backyard produce ingestion for infant (SENES 2009a).

Final – Environmental Risk Assessment for the Cameco Port Hope Conversion Facility

**b) Exposure Factors – Radiological** (CSA 2014; dietary intakes from Table G.9c, unless otherwise noted)

Age Group <sup>a</sup>	Infant	Child	Adult
Age	0-5 years	6-15 years	16-70 years
Inhalation Rate (m <sup>3</sup> /hr)	0.31	0.89	0.96
Incidental Water Ingestion Rate while swimming (L/h), IR <sub>swim</sub> <sup>b</sup>	0.05	0.05	0.05
Incidental Water Ingestion Rate - fall off boat into Harbour (L/h), IR <sub>fall</sub> <sup>b</sup>	0.05	0.05	0.05
Total Fish Ingestion Rate (g/d) <sup>e</sup>	6.4	18.5	28.1
Fraction local (fish) <sup>c</sup>	0	1	1
Local Fish Ingestion Rate (g/d)	0	18.5	28.1
Food (produce) Ingestion (g/d) <sup>d</sup>	342	726	1131.7
Fraction local (produce) <sup>e</sup>	0.25	0.25	0.25
Exposed skin surface area - swimming or fall in (cm <sup>2</sup> )	7,200	14,600	21,900
Incidental Soil Ingestion Rate (g dw/d)	0.204	0.185	0.020
Incidental Sediment Ingestion Rate (g dw/d)	0.204	0.185	0.020

Notes:

- <sup>a</sup> In the radiological assessment, three age groups were considered based on CSA (2014); these age groups correspond to the Infant, Child and Adult age groups presented above.
- <sup>b</sup> Water ingestion rate while swimming: 0.05 L/hr from U.S. EPA 1989 (value for non-competitive swimming).
- <sup>c</sup> No local fish ingestion assumed for infants (SENES 2009a).
- <sup>d</sup> CSA (2014) values for fruit and berries, vegetables, and potatoes.
- <sup>e</sup> CSA (2014) highest (most conservative) local fraction among fruit and berries, vegetables, and potatoes.
- <sup>f</sup> CSA (2014) Table 18.

Final – Environmental Risk Assessment for the Cameco Port Hope Conversion Facility

**c) Exposure Durations – Radiological & Non-Radiological (site-specific estimates)**

Age Group <sup>a</sup>	Infant	Toddler	Child	Teen	Adult
Time spent in contact with SW while swimming <sup>b</sup>					
(h/d)	2	2	2	2	2
(d/week)	7	7	7	7	7
(weeks/y)	12	12	12	12	12
Time spent in contact with SW - fall off boat into Harbour <sup>c</sup>					
(h/d)	0	0.2	0.2	0.2	0.2
(d/week)	0	1	1	1	1
(weeks/y)	0	1	1	1	1
Time spent exposed to residential soil <sup>d</sup>					
(h/d)	2	2	2	2	2
(d/week)	7	7	7	7	7
(weeks/y)	52	52	52	52	52
Time exposed to park soil <sup>d</sup>					
(h/d)	1	1	1	1	1
(d/week)	7	7	7	7	7
(weeks/y)	52	52	52	52	52
Time spent exposed to outdoor air (inh) <sup>e</sup>					
(h/d)	3.5	3.5	3.5	3.5	3.5
(d/week)	7	7	7	7	7
(weeks/y)	52	52	52	52	52
Fenceline walker time spent exposed to outdoor air (inh) <sup>e</sup>					
(h/d)	1	1	1	1	1
(d/week)	7	7	7	7	7
(weeks/y)	52	52	52	52	52

Final – Environmental Risk Assessment for the Cameco Port Hope Conversion Facility

Age Group <sup>a</sup>	Infant	Toddler	Child	Teen	Adult
Off-site Commercial Workers: Time spent exposed to outdoor air (inh) <sup>f</sup>					
(h/d)	n/a	n/a	n/a	n/a	1.6
(d/week)	n/a	n/a	n/a	n/a	5
(weeks/y)	n/a	n/a	n/a	n/a	50
Exposure Duration (y)	0.5	4-5	7	8	61
Averaging Time (y) - carc	80	80	80	80	80
- non-carc	1	1	1	1	1

Notes:

n/a – Not an applicable pathway for this receptor.

- <sup>a</sup> In the radiological assessment, three age groups are considered based on CSA (2014); these age groups correspond to the Infant, Child and Adult age groups presented above.
- <sup>b</sup> Based on swimming 2 hr/d, 7d/wk, in Summer (June, July, and August).
- <sup>c</sup> Consistent with SENES (2009, 2010) SWRA.
- <sup>d</sup> Residential soil exposure estimate based on assumption of 2 hr/d, 7d/wk of outdoor activities (e.g. gardening, swimming, etc.). Park user estimate based on assumption of 1 hr/d, 7 d/wk.
- <sup>e</sup> HC (2010) PQRA default value is 1.5 hr/d. A value of 3.5 hr/d was selected to include the 1.5 hr/d default and account for 2 hr/d of outdoor time spent engaging in other outdoor exposure activities (e.g. gardening or swimming). Fenceline worker assumed to spend 1 hr/d walking outdoors (Cameco assumption).
- <sup>f</sup> Based on 2,000 h/y of commercial work, of which 200 h/y is assumed to be spent outdoors for workers near the PHCF, and 400 h/y is assumed to be spent outdoors for workers near Dorset Street (Cameco assumption).

### 5.2.3 Exposure Point Concentrations

Section 5.2.1 discusses the environmental media that each human receptor can be exposed to, the pathways through which they can potentially be exposed, and the different spatial areas within each medium (e.g., while soil is a general environmental medium, it is further divided into discrete areas such as the off-site residential yards, on-site areas, etc.).

The following tables present summary statistics for each distinct area of environmental media, relevant to the identified receptors and pathways. These summary statistics are used as exposure point concentrations in subsequent exposure calculations.

#### 5.2.3.1 Soil, Groundwater and Surface Water

**Air** concentrations for HHRA public receptor calculations are based on AERMOD modelling of PHCF airborne emissions. The resulting modelled air concentrations are presented in Section 3 above.

**Soil** concentrations for HHRA public resident receptor calculations (uranium only) were selected as discussed in Section 3.2. The resulting soil concentration data are presented in Table 5.9.

**Harbour surface water** concentrations for HHRA public receptor calculations are presented in Table 5.10.

**Beach surface water** concentrations for HHRA public receptor calculations are presented in Table 5.11.

Table 5.9 HHRA – Soil Concentrations – Off-Site Residential Yard Soil Concentrations (PHCF and Dorset Street East Sites)

Analyte	Maximum Measured Soil Concentration, All Depths (µg/g)					95% UCLM <sup>b</sup> (µg/g)
	Station #	1	2	12	19	
NO2+NO3	25	28	25	25	25	NC
Aluminum	8500	25400	15900	17700	14500	
Antimony	1.9	0.3	7.3	0.8	27.0	
Arsenic	26	4	57	10	17	20.9
Barium	41	140	92	130	110	NC
Boron	11	32	130	25	24	
Cadmium	0.30	0.40	1.00	0.50	0.30	
Chromium	16	39	29	25	28	
Cobalt	5.8	9.3	25.0	6.4	5.2	
Copper	15	16	66	20	11	
Iron	16700	27000	31700	20400	17800	
Lead	44	12	420	211	270	
Manganese	340	570	410	450	370	
Molybdenum	0.40	0.80	5.20	0.70	1.70	
Nickel	6.40	12.00	35.00	14.00	8.50	
Selenium	0.20	0.40	1.00	0.80	0.30	
Silver	0.40	0.10	0.90	0.20	0.20	
Strontium	180.0	110.0	190.0	140.0	140.0	
U	10.0	1.4	9.2	3.5	7.6	
V	29	58	36	38	34	
Zn	70	66	500	150	170	
U-238 a	0.12	0.017	0.11	0.043	0.094	
U-234 a	0.12	0.017	0.11	0.043	0.094	
U-235 a	0.0057	0.0008	0.0052	0.002	0.0043	

Notes:

Radionuclide data not available for these locations. Concentrations of U-238, U-234 and U-235 were estimated from total measured uranium concentration.

NC – Not calculated.

<sup>a</sup> Calculated from total uranium, using specific activity.

<sup>b</sup> 95% UCLM – 95th percentile upper confidence limit for the mean, calculated using US EPA ProUCL.

Final – Environmental Risk Assessment for the Cameco Port Hope Conversion Facility

Table 5.10 HHRA – Harbour Surface Water Concentrations for Off-Site Public Receptors

Analytes	Units	N	N <MDL	% <MDL	Minimum	Maximum	Arithmetic Mean	Geometric Mean	Std. Dev.	95th Percentile	95% UCLM <sup>a</sup>	Incremental <sup>b</sup>
Fluoride	ug/L	104	8	8%	<0.1	0.3	0	0	0	0	NC	NC
Ammonia (Total)	mg N/L	104	11	11%	<0.1	0.5	0	0	0	0	NC	NC
Chloride	mg/L	28	0	0%	14.00	130.00	21.07	18.17	21.48	22.30	NC	NC
Potassium	mg/L	33.00	0.00	0%	1.23	5.65	1.49	1.42	0.76	1.68	NC	NC
Phosphorus	mg/L	33.00	5.00	15%	<0.005	0.04	0.02	0.02	0.01	0.03	NC	NC
Aluminum	mg/L	33.00	0.00	0%	0.02	0.15	0.06	0.06	0.03	0.12	NC	NC
Arsenic	ug/L	104.00	16.00	15%	<1.2	3.20	1.66	1.51	0.67	2.89	1.85	Max - 0.82 95 <sup>th</sup> %ile- 0.63
Strontium	mg/L	33.00	0.00	0%	0.16	0.18	0.17	0.17	0.01	0.18	NC	NC
Uranium	ug/L	104.00	0.00	0%	0.80	12.00	4.77	4.11	2.49	8.49	NC	NC
Zinc	mg/L	33.00	1.00	3%	<0.0005	0.01	0.00	0.00	0.00	0.01	NC	NC
Dichlorodi- fluoromethane	ug/L	8	8	100%	<5	<5	NC	NC	NC	NC	NC	NC
Pb-210	Bq/L	2	1	50%	<0.1	0.1	0.075	0.071	0.035	NC	NC	NC
Po-210	Bq/L	2	2	100%	<0.01	<0.01	<0.01	<0.01	0.00	NC	NC	NC
Ra-224	Bq/L	2	2	100%	<0.01	<0.01	<0.01	<0.01	0.00	NC	NC	NC
Ra-226	mBq/L	103	99	96%	<55	110	30.2	29	12.7	27.5	NC	NC
Ra-228 <sup>c</sup>	Bq/L	2	2	100%	<0.01	<0.01	<0.01	<0.01	0.00	NC	NC	NC
Th-228	Bq/L	2	2	100%	<0.01	<0.01	<0.01	<0.01	0.00	NC	NC	NC
Th-230	Bq/L	2	2	100%	<0.01	<0.01	<0.01	<0.01	0.00	NC	NC	NC
Th-232	Bq/L	2	2	100%	<0.01	<0.01	<0.01	<0.01	0.00	NC	NC	NC



Final – Environmental Risk Assessment for the Cameco Port Hope Conversion Facility

Analytes	Units	N	N <MDL	% <MDL	Minimum	Maximum	Arithmetic Mean	Geometric Mean	Std. Dev.	95th Percentile	95% UCLM <sup>a</sup>	Incremental <sup>b</sup>
U-234	Bq/L	3	1	33%	<0.1	0.115	0.075	0.070	0.035	NC	NC	NC
U-235	Bq/L	3	2	67%	<0.01	0.01	0.0067	0.0063	0.0029	NC	NC	NC
U-238	Bq/L	3	0	0%	0.07	0.11	0.087	0.085	0.021	NC	NC	NC

Note:

As, F, NH<sub>3</sub>, U and Ra-226 based on 2014 data. The remaining COPCs are based on 2008-2009 data.

<sup>a</sup> 95% UCLM – 95<sup>th</sup> percentile upper confidence limit for the mean, calculated using US EPA ProUCL.

<sup>b</sup> Incremental – estimated concentrations based on loadings from groundwater and surface water. Estimates are for Station 9 – harbour mouth - Scenario 1c: combined effects of stormwater and groundwater (average i.e., not dynamic Stormwater), using maximum loadings. “Max” - Maximum modelled concentration among surface, middle, and bottom depths. “95<sup>th</sup> %ile” – 95<sup>th</sup> percentile modelled concentration among surface, middle, and bottom depths. See Section 3.3 for details.

<sup>c</sup> Ra-228 assumed equal to Ra-224, secular equilibrium. See Table 2.1.

NC – not calculated.

Final – Environmental Risk Assessment for the Cameco Port Hope Conversion Facility

Table 5.11 HHRA – Beach Surface Water Concentrations for Off-Site Public Receptors

Analytes	Units	N	N<MDL	%<MDL	Minimum	Maximum	Arithmetic Mean	Geometric Mean	Std. Dev.	95th Percentile	95% UCLM <sup>a</sup>	Incremental <sup>b</sup>
Fluoride	mg/L	10	5	50%	<0.06	0.12	0.074	0.059	0.046	0.12	0.12	NC
Ammonia (Total)	mg N/L	10	9	90%	<0.1	0.1	0.055	0.054	0.016	0.078	NC	NC
Chloride	mg/L	10	0	0%	25	29	27.10	27.06	1.52	29.00	NC	NC
Potassium	mg/L	10.00	0.00	0.00	1.70	1.96	1.82	1.82	0.11	1.95	NC	NC
Phosphorus	mg/L	10.00	10.00	1.00	<0.01	<0.01	<0.01	<0.01	0.00	<0.01	NC	NC
Aluminum	mg/L	10.00	4.00	0.40	<0.01	0.07	0.02	0.01	0.02	0.06	NC	NC
Arsenic	mg/L	10	0	0%	0.0011	0.0014	0.0012	0.0012	0.000095	0.0014	0.0013	Max – 4.5E-05 95 <sup>th</sup> %ile – 2.0E-05
Strontium	mg/L	10	0	0%	0.171	0.179	0.17	0.17	0.0023	0.18	0.18	NC
Uranium	mg/L	10	0	0%	0.000623	0.000934	0.00074	0.00074	0.000099	0.00089	0.00080	Max – 1.4E-04 95 <sup>th</sup> %ile – 4.3E-05
Zinc	mg/L	10	5	50%	<0.001	0.001	0.00075	0.00071	0.00026	0.0010	NC	NC
Dichlorodifluoromethane	µg/L	10	10	100%	<2	<2	NC	NC	NC	NC	NC	NC

Final – Environmental Risk Assessment for the Cameco Port Hope Conversion Facility

Analytes	Units	N	N<MDL	%<MDL	Minimum	Maximum	Arithmetic Mean	Geometric Mean	Std. Dev.	95th Percentile	95% UCLM <sup>a</sup>	Incremental <sup>b</sup>
Ra-226	Bq/L	10	10	100%	<0.055	<0.055	<0.055	<0.055	0.00	<0.055	NA	Max – 4.2E-05 95 <sup>th</sup> %ile - 1.3E-05
U-238 <sup>c</sup>	Bq/L	NA	NA	NA	NA	0.0115	NA	NA	NA	NA	NA	NC
U-234 <sup>c</sup>	Bq/L	NA	NA	NA	NA	0.0115	NA	NA	NA	NA	NA	NC
U-235 <sup>c</sup>	Bq/L	NA	NA	NA	NA	5.3E-04	NA	NA	NA	NA	NA	NC

Notes:

Beach surface water concentrations are based on 2008-2009 data.

Radionuclide data (other than Ra-226) not available for these locations. Concentrations of U-238, U-234 and U-235 were estimated from total measured uranium concentration.

<sup>a</sup> 95% UCLM – 95<sup>th</sup> percentile upper confidence limit for the mean, calculated using US EPA ProUCL.

<sup>b</sup> Incremental - estimated concentrations based on loadings from groundwater and surface water. Estimates are for Station 15 – West Beach (EH1) - Scenario 1c: combined effects of stormwater and groundwater (average i.e., not dynamic Stormwater), using maximum loadings. "Max" - Maximum modelled concentration among surface, middle, and bottom depths. "95<sup>th</sup> %ile" – 95<sup>th</sup> percentile modelled concentration among surface, middle, and bottom depths. See Section 3.3 for details.

<sup>c</sup> Calculated from total uranium, using specific activity.

NA – not applicable.

NC – not calculated.

ND – no data.

### 5.2.3.2 Direct Gamma

Also included in the radiological component of the HHRA is the dose contribution from direct gamma radiation.

For off-site receptors, a combination of modelled and measured gamma dose rates was derived based on representative quantities of radioactive material stored on-site at the PHCF (including Centre Pier) and the Dorset Street East facility. [REDACTED]

## 5.2.4 Radiological Dose Calculation Methods

### 5.2.4.1 Internal Dose from Inhalation

The radiological dose from inhalation is calculated for each radionuclide using Equation 5-1, based on the methodology from CSA (2012):

$$D_{inh} = IR \times DC_{inh} \times C_{air} \times OF \quad (5-1)$$

Where:

- $D_{inh}$  = internal radiation dose from inhalation [Sv/yr]
- IR = inhalation rate [ $m^3/yr$ ]
- $DC_{inh}$  = inhalation dose coefficient [Sv/Bq]
- $C_{air}$  = concentration in air [ $Bq/m^3$ ]
- OF = occupancy factor (fraction of time exposed) [unitless]

### 5.2.4.2 Internal Dose from Incidental Ingestion of Groundwater

The radiological dose from incidental ingestion of groundwater is calculated for each radionuclide using Equation 5-2, based on the incidental soil ingestion methodology from CSA (2012):

$$D_{gw} = I_{gw} \times EF_{gw} \times DC_f \times C_{gw} \quad (5-2)$$

Where:

- $D_{gw}$  = internal radiation dose from incidental ingestion of groundwater [Sv/yr]
- $I_{gw}$  = incidental groundwater ingestion rate [L/d]
- $EF_{gw}$  = days per year in which the incidental ingestion could occur [d/yr]

$DC_f$  = internal dose coefficient for intake by ingestion [Sv/Bq]

$C_{gw}$  = concentration in groundwater [Bq/L]

#### 5.2.4.3 Internal Dose from Incidental Ingestion of soil

The radiological dose from incidental ingestion of soil is calculated for each radionuclide, following Equation 5-3 (CSA 2012):

$$D_s = I_s \times EF_s \times DC_f \times C_s \quad (5-3)$$

Where:

$D_s$  = internal radiation dose from incidental ingestion of soil [Sv/yr]

$I_s$  = incidental soil ingestion rate [kg/d]

$EF_s$  = days per year in which the incidental ingestion could occur [d/yr]

$DC_f$  = internal dose coefficient for intake by ingestion [Sv/Bq]

$C_s$  = concentration in soil [Bq/kg]

#### 5.2.4.4 Internal Dose from Ingestion of Contaminated Foods

The radiological dose from ingestion of contaminated food is calculated for each radionuclide, following Equation 5-4 (CSA 2012):

$$D_f = \rho_f \times g_f \times I_f \times DC_f \times C_f \quad (5-4)$$

Where:

$D_f$  = internal radiation dose from ingestion of contaminated food [Sv/yr]

$\rho_f$  = adjustment factor for food processing (assumed to be 1) [unitless]

$g_f$  = fraction of food from contaminated source (assumed to be 1) [unitless]

$I_s$  = food ingestion rate [kg/yr]

$DC_f$  = internal dose coefficient for intake by ingestion [Sv/Bq]

$C_s$  = concentration in soil [Bq/kg]

#### 5.2.4.5 External Dose from Immersion in Surface Water

The radiological external dose from immersion in surface water (while swimming, or falling into the harbour) is calculated for each radionuclide, following Equation 5-5 (CSA 2012):

$$D_{wi} = DC_{wi} \times (OF_w + D_c \times \rho \times OF_w' + \rho \times OF_w'') \times C_{wi} \quad (5-5)$$

Where:

- $D_{wi}$  = external radiation dose from immersion in water [Sv/hr]
- $DC_{wi}$  = external dose coefficient for immersion in contaminated water [Sv/yr per Bq/L]
- $OF_w$  = fraction of the year spent immersed in surface water [unitless]
- $D_c$  = Correction factor to account for finite size of bathtub – not applicable for immersion in surface water body (assumed equal to zero) [unitless]
- $\rho$  = correction factor to account for processes that may remove radionuclides from water (e.g., sedimentation, water treatment plant, etc.) – assume no removal (assumed equal to zero) [unitless]
- $OF_w'$  = fraction of time spent bathing – not applicable, bathing assumed to use municipal water, not surface water (assumed equal to zero) [unitless]
- $OF_w''$  = fraction of time spent swimming in pool – not applicable, pools assumed to use municipal water, not surface water (assumed equal to zero) [unitless]
- $C_{wi}$  = surface water concentration for immersion [Bq/L]

#### 5.2.4.6 External Dose from Ground Deposits

The radiological external dose from ground deposits (also known as groundshine), measures the external dose from exposure to a contaminated surface, as follows (from CSA 2012):

$$P(e)_{3area9} = f_o \times f_r \times [f_u + (1-f_u) \times S_g] \times (DCF)_g \quad (5-6)$$

where

- $f_o$  = fraction of total time spent by the individual at the exposure location (unitless). See further discussion of this parameter below.
- $f_r$  = dose reduction factor to account for non-uniformity of the ground surface (unitless). The modifying factor,  $f_r$ , accounts for surface roughness and terrain irregularities; as per CSA (2012), a value of 0.7 was used.

$f_u$  = time spent outdoors at the exposure location as a fraction of total time spent at that location (unitless).

$S_g$  = shielding factor for groundshine, or fraction of the outdoor groundshine dose received indoors due to shielding by buildings (unitless); a value of 0.2 was used, as per CSA (2012).

$(DCF)_g$  = effective dose coefficient for an infinite plane ground deposit [ $\text{Sv}\cdot\text{a}^{-1}\cdot\text{Bq}^{-1}\cdot\text{m}^2$ ].

The default value of  $f_u$  is 0.2. The default value of  $f_o$ , which accounts for working and living at different locations, is 1 (see Clause 6.2.4 of CSA 2012).

The  $f_o$  value was set based on the exposure parameters defined in Section 5.2.2. For example, a resident would have a  $f_o$  value of 1, whereas a commercial worker would have a  $f_o$  value of 0.23 (i.e., 2,000 h/y divided by 8,766 h/y, assuming that the commercial worker only spends 2,000 h/y in Port Hope). In order to be conservative, the commercial worker dose is later added to the resident dose, to account for a commercial worker who may also live in Port Hope.

## 5.2.5 Gamma External Dose Calculation Methods

In general, the dose from exposure to gamma radiation is calculated following Equation 5-7:

$$D_g = DR_g \times D_1 \times D_2 \quad (5-7)$$

Where:

$D_g$  = external gamma radiation dose [ $\mu\text{Sv}/\text{yr}$ ]

$DR_g$  = measured or modelled gamma dose rate [ $\mu\text{Sv}/\text{hr}$ ]

$D_1$  = hours per day over which the exposure occurs [hr/d]

$D_2$  = days per year over which the exposure occurs [d/yr]



### 5.2.6 Dose Coefficients

Radiological assessment involves the use of dose coefficients (DCs) that convert environmental concentrations or intakes into doses to human receptors. In the case of external exposure to gamma radiation, on-site monitoring measurements were used.

The DCs used in the radiological HHRA calculations were selected from literature references using the following hierarchy, consistent with CSA (2012):

- a. CSA N288.1 (2014); and
- b. ICRP 72 (1996).

Table 5.12 summarizes the DCs that were selected for the HHRA calculations.



Final – Environmental Risk Assessment for the Cameco Port Hope Conversion Facility

Table 5.12 HHRA – Dose Coefficients

Radionuclide	Effective Dose Coefficients for Ingestion (in Sv/Bq)			
	Infant	Child	Adult	Ref
Pb-210	3.61E-06	2.20E-06	6.91E-07	ICRP 72 (1995), for ages 1 yr, 5 yr and Adult
Po-210	8.80E-06	4.40E-06	1.20E-06	ICRP 72 (1995), for ages 1 yr, 5 yr and Adult
Ra-224	6.6E-07	2.6E-07	6.5E-08	CSA N288.1 (2014), Table C.2
Ra-226	9.60E-07	8.00E-07	2.80E-07	CSA N288.1 (2014), Table C.2
Ra-228	5.70E-06	3.90E-06	6.90E-07	CSA N288.1 (2014), Table C.2
Th-228	3.7E-07	1.5E-07	7.2E-08	CSA N288.1 (2014), Table C.2
Th-230	4.10E-07	3.10E-07	2.10E-07	ICRP 72 (1995), for ages 1 yr, 5 yr and Adult
Th-232	4.50E-07	2.90E-07	2.30E-07	CSA N288.1 (2014), Table C.2
U-235	1.30E-07	7.10E-08	4.70E-08	CSA N288.1 (2014), Table C.2
U-238	1.20E-07	6.80E-08	4.50E-08	CSA N288.1 (2014), Table C.2
U-234	1.30E-07	7.40E-08	4.90E-08	CSA N288.1 (2014), Table C.2
Radionuclide	Effective Dose Coefficients for Immersion in Water (in Sv/y per Bq/m <sup>3</sup> )			
	Infant	Child	Adult	Ref
Pb-210	6.13E-12	6.13E-12	6.13E-12	U.S. EPA (1993), Table III.2 (Adult values)
Po-210	2.85E-14	2.85E-14	2.85E-14	U.S. EPA (1993), Table III.2 (Adult values)
Ra-224	3.25E-11	3.25E-11	3.25E-11	U.S. EPA (1993), Table III.2 (Adult values)
Ra-226	1.20E-09	9.22E-10	9.22E-10	CSA N288.1 (2014), Table C.5
Ra-228	3.28E-09	3.28E-09	3.28E-09	U.S. EPA (1993), Table III.2 (Adult values)
Th-228	5.44E-10	4.18E-10	4.18E-10	CSA N288.1 (2014), Table C.5
Th-230	1.24E-12	1.24E-12	1.24E-12	U.S. EPA (1993), Table III.2 (Adult values)
Th-232	6.72E-13	5.17E-13	5.17E-13	CSA N288.1 (2014), Table C.5
U-235	5.86E-10	4.51E-10	4.51E-10	CSA N288.1 (2014), Table C.5
U-238	3.27E-12	2.52E-12	2.52E-12	CSA N288.1 (2014), Table C.5
U-234	5.71E-13	4.39E-13	4.39E-13	CSA N288.1 (2014), Table C.5
Radionuclide	Effective Dose Coefficients for Inhalation (in µSv per Bq)			
	Infant	Child	Adult	Ref
Pb-210	1.80E+01	1.10E+01	5.60E+00	ICRP 72 (1995): 1 yr, 5 yr and Adult - Type S
Po-210	1.40E+01	8.60E+01	4.30E+00	ICRP 72 (1995): 1 yr, 5 yr and Adult
Ra-224	9.20E+00	5.90E+00	3.40E+00	ICRP 72 (1995): 1 yr, 5 yr and Adult
Ra-226	1.10E+01	4.90E+00	3.50E+00	CSA N288.1 (2014) Table C.1
Ra-228	4.80E+01	3.20E+01	1.60E+01	ICRP 72 (1995): 1 yr, 5 yr and Adult - Type S
Th-228	1.30E+02	5.50E+01	4.00E+01	CSA N288.1 (2014) Table C.1
Th-230	3.50E+01	2.40E+01	1.40E+01	ICRP 72 (1995): 1 yr, 5 yr and Adult - Type S
Th-232	5.00E+01	2.60E+01	2.50E+01	CSA N288.1 (2014) Table C.1
U-235	1.00E+01	4.30E+00	3.10E+00	CSA N288.1 (2014) Table C.1
U-238	9.40E+00	4.00E+00	2.90E+00	CSA N288.1 (2014) Table C.1
U-234	1.10E+01	4.80E+00	3.50E+00	CSA N288.1 (2014) Table C.1

**Notes:**

Pb-210 includes Bi-210; Ra-226 includes Pb-214, Bi-214, Po-218 and Po-214.

Ra-228 includes Ac-228; Th-228 includes Ra-224, Po-216, Pb-212, Bi-212, (0.36)Tl-208, (0.64)Po-212.

U-235 includes Th-231; U-238 includes Th-234 and Pa-234m.

## 5.2.7 Non-Radiological Dose Calculation Methods

### 5.2.7.1 Incidental Ingestion of Soil

The non-radiological dose from incidental ingestion of soil is calculated for each COPC following Equation 5-8, based on CSA (2012):

$$D_s = \frac{C_s \times IR_s \times AF_{GIT} \times D_1 \times D_2 \times D_3}{BW \times LE} \quad (5-8)$$

Where:

- $D_s$  = dose from incidental ingestion of soil [mg/kg/d]
- $C_s$  = concentration of COPC in soil [mg/kg]
- $IR_s$  = incidental soil ingestion rate [kg/d]
- $AF_{GIT}$  = absorption factor for gastrointestinal tract (assumed equal to 1) [unitless]
- $D_1$  = days per week exposed, divided by 7 days [d/d]
- $D_2$  = weeks per year exposed, divided by 52 weeks [wk/wk]
- $D_3$  = total years exposed to site (for carcinogens only) [yr]
- $BW$  = receptor body weight [kg]
- $LE$  = Life expectancy (for carcinogens only) [yr]

As shown in Table 5.7, an averaging time of 1 is used for assessing chronic exposure, whereas an averaging time of 0.5 is used for assessing short-term exposure (along with the appropriate short-term TRVs). In present calculations chronic exposure is assessed, and therefore the averaging time fraction is excluded.

### 5.2.7.2 Ingestion of Contaminated Food

The non-radiological dose from ingestion of contaminated food is calculated for each COPC, following Equation 5-9 (CSA 2012):

$$D_{f\_ing} = \frac{[\sum (C_{food\_i} \times IR_{food\_i} \times RAF_{GIT} \times D_1)] \times D_2}{BW \times LE \times 365} \quad (5-9)$$

Where:

- $D_{f\_ing}$  = dose from contaminated food ingestion [mg/kg/d]
- $C_{food\_i}$  = concentration of COPC in food item “i” [mg/kg]
- $IR_{food\_i}$  = ingestion rate of food item “i” [kg/d]

- RAF<sub>GIT</sub> = relative absorption factor for the gastrointestinal tract, for a particular COPC, in food item “i” (assumed equal to 1) [unitless]
- D<sub>1</sub> = days per year over which the consumption of food “i” occurs [d/yr]
- D<sub>2</sub> = total years exposed to site (for carcinogens only) [yr]
- BW = receptor body weight [kg]
- LE = Life expectancy (for carcinogens only) [yr]
- 365 = total days per year (constant) [d/yr]

For the purposes of this study, fish consumption is assumed to occur 365 days per year (D1). Therefore, mathematically D1 (numerator) and 365 (denominator) in the equation above can be omitted.

The concentration of COPCs in food (fish and produce) is calculated using the Transfer Factors presented in Table 6.24; however, a notable exception exists for fish, where transfer factors are obtained preferentially from CSA N288.1 (2014) since these TFs represent concentrations in fish muscle which more appropriately represents the edible portion of fish.

### 5.2.7.3 Incidental Ingestion of Surface Water While Swimming

The non-radiological dose from incidental ingestion of surface water while swimming (or falling into the harbour) is calculated for each COPC, following Equation 5-10 (CSA 2012):

$$D_{sw} = \frac{C_{sw} \times IR_{sw} \times ET \times EF \times ED}{BW \times AT} \quad (5-10)$$

Where:

- D<sub>sw</sub> = dose from incidental ingestion of surface water while swimming or falling into the harbour [mg/kg/d]
- C<sub>sw</sub> = concentration of COPC in surface water [mg/L]
- IR<sub>sw</sub> = incidental surface water ingestion rate [L/hr]
- ET = exposure time [hours/event]
- EF = exposure frequency [events/yr]
- ED = exposure duration [yrs]
- BW = receptor body weight [kg]
- AT = averaging time (i.e., period over which the exposure is averaged) [d]

#### 5.2.7.4 Soil Dermal Uptake

The non-radiological dose from dermal soil uptake is calculated for each COPC, following Equation 5-11. Equation 5-11 is based on the calculation methods of Health Canada (2012a) and US EPA (2004), with terms included for averaging time (for carcinogenic COPC calculations), consistent with CSA (2012):

$$D_{dermal}^s = \frac{C_s \times SA \times SL \times RAF \times EF_s \times \frac{D_2}{7} \times \frac{D_3}{52} \times D_4 \times CF}{BW \times AT}$$

(5-11)

Where:

$D_{dermal}^s$	= exposure to COPC in soil through the dermal pathway [mg/(kg-d)]
$C_s$	= soil concentration [mg/kg]
SA	= exposed skin surface area [cm <sup>2</sup> ]
SL	= soil loading to exposed skin [(mg)/(cm <sup>2</sup> event)]
RAF	= dermal absorption factor [-]
EFs	= exposure frequency to soil [events/d]
$D_2/7$	= days per week exposed/7 days [d/d]
$D_3/52$	= weeks per year exposed/52 weeks [wk/wk]
$D_4$	= total years exposed to site (for carcinogenic COPC only) [yr]
BW	= receptor body weight [kg]
AT	= averaging time (for carcinogenic COPC only) [yr]
CF	= conversion factor $1.0 \times 10^{-6}$ [kg/mg]

The value for the soil loading to exposed skin is based on the soil adherence value, which represents the amount of soil retained on the skin, and the skin surface area. Several studies have attempted to determine the soil adherence value and are summarized in U.S. EPA (2004b). Health Canada (2012a) provides separate adherence factors for hands and other surfaces which are summed to provide a total exposed skin surface area.

Table 5.13 summarizes the dermal absorption fractions used in the calculations of dermal exposure to soil. Values were obtained according to the following hierarchy:

1. Health Canada (2012b);
2. OMOE (2011);
3. US EPA (2004);
4. Default value of 10% (Health Canada 2012b).

Table 5.13 HHRA – Dermal Absorption Factors (Soil)

COPC	Dermal Absorption Factors [unitless]
Fluoride	0.1 <sup>c</sup>
Ammonia	0.1 <sup>c</sup>
Antimony	0.1 <sup>c</sup>
Arsenic	0.03 <sup>a</sup>
Cadmium	0.01 <sup>a</sup>
Cobalt	0.01 <sup>b</sup>
Copper	0.06 <sup>a</sup>
Iron	0.1 <sup>c</sup>
Nickel	0.091 <sup>a</sup>
Lead	0.1 <sup>c</sup>
Selenium	0.01 <sup>a</sup>
Strontium	0.1 <sup>c</sup>
Uranium	0.1 <sup>a</sup>
Zinc	0.1 <sup>a</sup>
Benzene	0.03 <sup>a</sup>
Carbon Tetrachloride	0.03 <sup>a</sup>
Chloroform	0.03 <sup>b</sup>
1,1-Dichloroethylene	0.03 <sup>a</sup>
cis-1,2-Dichloroethylene	0.03 <sup>b</sup>
trans-1,2-Dichloroethylene	0.03 <sup>b</sup>
Trichloroethylene	0.03 <sup>a</sup>
Vinyl Chloride	0.03 <sup>a</sup>
Ethylenedibromide	0.03 <sup>a</sup>
PCBs	0.14 <sup>a</sup>
PHCs F1-F4	0.2 <sup>a</sup>

Note:

<sup>a</sup> Health Canada (2012b).

<sup>b</sup> OMOE (2011).

<sup>c</sup> default value of 0.1 (10%) for inorganics (consistent with Health Canada 2012b).

### 5.2.7.5 Surface Water Dermal Uptake

The non-radiological dose from dermal uptake of water (surface water or groundwater) is calculated for each COPC, following the general Equation 5-12 (based on US EPA 2004, consistent with CSA 2012). However, this calculation varies depending on the COPC by way of the absorbed dose term (i.e.,  $DA_{ev}$  in the Equation 5-12 below), which is calculated using different methods for inorganic COPCs versus organic COPCs:

$$D_{dermal}^w = \frac{DA_{ev} \times SA \times EF_w \times \frac{D_2}{7} \times \frac{D_3}{52} \times D_4}{BW \times AT} \quad (5-12)$$

Where:

- $D_{dermal}^w$  = exposure to COPC in water through the dermal pathway [mg/(kg-d)]
- $DA_{ev}$  = absorbed dose per event [mg/cm<sup>2</sup>/event]
- SA = exposed skin surface area [cm<sup>2</sup>]
- $EF_w$  = exposure frequency to water [events/d] {assumed to be 1 event per day}
- $D_2/7$  = days per week exposed/7 days [d/d]
- $D_3/52$  = weeks per year exposed/52 weeks [wk/wk]
- $D_4$  = total years exposed to site (for carcinogenic COPC only) [yr]
- BW = body weight [kg]
- AT = averaging time (for carcinogenic COPCs only) [yr]

#### Inorganic COPCS - $DA_{ev}$

For inorganic COPCs, the skin has a limited capacity to reduce the transport rate and the viable epidermis does not act as a barrier. Therefore, the absorbed dose ( $DA_{ev}$ ) can be calculated from Equation 5-13:

$$DA_{ev} = \frac{K_p \times C_w \times t_{ev}}{CF} \quad (5-13)$$

Where:

- $DA_{ev}$  = absorbed dose per event [mg/cm<sup>2</sup>/ev]
- $K_p$  = dermal permeability coefficient in water [cm/h]

- $C_w$  = groundwater concentration [ $\mu\text{g/L}$ ]  
 $t_{ev}$  = event duration [h/d], calculated as the product of the exposure frequency ( $EF_w$ ) and the hours per day exposed ( $D_{1-out}$ )  
 $CF$  = conversion factor  $1 \times 10^{-6}$  [( $\text{mg}/\text{cm}^3$ )/( $\mu\text{g}/\text{L}$ )]

In this study, the exposure times used in dermal uptake equations are those presented in Table 5.8.

Organic COPCS -  $DA_{ev}$

For organic COPCs, the calculation is dependent on the contact time and the time required to reach steady state. Equations 5-14 and 5-15 are used to estimate the absorbed dose ( $DA_{ev}$ ):

$$\text{If } t_{ev} \leq t^* \quad DA_{ev} = 2 \times FA \times K_p \times \frac{C_w}{CF} \sqrt{6 \tau \frac{t_{ev}}{\pi}} \quad (5-14)$$

$$\text{If } t_{ev} > t^* \quad DA_{ev} = FA \times K_p \times \frac{C_w}{CF} \left[ \frac{t_{ev}}{1+B} + 2\tau \left( \frac{1+3B+3B^2}{(1+B)^2} \right) \right] \quad (5-15)$$

Where:

- $FA$  = fraction absorbed [-]  
 $\tau$  = lag time [h]  
 $t_{ev}$  = event time (duration) [h]  
 $t^*$  = time to reach steady state [h]  
 $CF$  = conversion factor  $1 \times 10^{-6}$  [( $\text{mg}/\text{cm}^3$ )/( $\mu\text{g}/\text{L}$ )]  
 $B$  = ratio of the permeability coefficient of a compound through the stratum corneum relative to its permeability coefficient across the viable epidermis

In this study, the exposure times used in dermal uptake equations are those presented in Table 5.8.

For highly lipophilic chemicals or for chemicals that have a long lag time, some of the chemical dissolved into skin may be lost due to desquamation during that absorption period. The fraction absorbed ( $FA$ ) term has been included to account for this loss of chemical due to desquamation. The conservative default for this parameter is 1 (i.e., assuming no loss due to desquamation); however, alternative values can be obtained on a chemical-specific basis from U.S. EPA (2004).

An empirical predictive correlation is provided to estimate the permeability coefficient for organics:

$$\log K_p = -2.80 + 0.66 \log K_{ow} - 0.0056 MW \quad (5-16)$$

Where:

$K_{ow}$  = octanol-water partition coefficient

MW = molecular weight [g/mole]

Chemicals with very large and very small  $K_{ow}$  values are outside of the range of the empirical relationship; however, the relationship can be used as a preliminary estimate (U.S. EPA 2004).

Assuming that the thickness of the stratum corneum is 0.001 cm the following equation can be used to determine the lag time:

$$\tau = 0.105 \times 10^{(0.0056 MW)} \quad (5-17)$$

For longer exposure durations, the absorbed dose is restricted by the permeability of the viable epidermis and the stratum corneum, and thus B, the ratio of the permeability of the stratum corneum to that of the epidermis is an important factor in the equation. The value of B can be approximated by:

$$B = K_p \frac{\sqrt{MW}}{2.6} \quad (5-18)$$

The calculation of the time to reach steady state ( $t^*$ ) is dependent on B according to the following equations:

$$\text{If } B \leq 0.6 \quad t^* = 2.4\tau \quad (5-19)$$

$$\text{If } B > 0.6 \quad t^* = 6\tau(b - \sqrt{b^2 - c^2}) \quad (5-20)$$

$$c = \frac{1 + 3B + 3B^2}{3(1 + B)} \quad (5-21)$$

$$b = \frac{2(1 + B)^2}{\pi} - c \quad (5-22)$$

Where:

b,c = correlation coefficients

Table 5.14 summarizes the dermal permeability coefficients ( $K_p$  values) used in the calculations of dermal exposure to groundwater.



Table 5.14 HHRA – Dermal Permeability Coefficients

(Applicable to Surface Water or Groundwater)

COPC	Dermal Permeability Coefficient ( $K_p$ ) (cm/h) <sup>(a)</sup>
Fluoride	1.0E-03*
Ammonia	1.0E-03
Antimony	1.0E-03
Arsenic	1.0E-03
Bromide	1.0E-03*
Cadmium	1.0E-03
Calcium	1.0E-03*
Cobalt	4.0E-04
Copper	1.0E-03
Chloride	1.0E-03*
Dichlorodifluoromethane	9.0E-03
Iron	1.0E-03
Nickel	2.0E-04
Nitrate	1.0E-03*
Nitrite	1.0E-03*
Lead	1.0E-04
Magnesium	1.0E-03
Potassium	2.0E-03
Phosphate	1.0E-03*
Phosphorus	1.0E-03*
Selenium	1.0E-03
Strontium	1.0E-03
Sulphate	1.0E-03*
Uranium	1.0E-03
Zinc	6.0E-04
TDS	-
Benzene	1.5E-02
Carbon Tetrachloride	1.6E-02
1,1-Dichloroethylene	1.2E-02
cis-1,2-Dichloroethylene	7.7E-03
trans-1,2-Dichloroethylene	7.7E-03
Trichloroethylene	1.2E-02
Vinyl Chloride	5.6E-03
Chloroform	6.8E-03
PCBs	7.5E-01 <sup>a,b</sup>
PHC F2 Aliphatic	3.39
PHC F2 Aromatic	0.05
PHC F3 Aliphatic	NC (see discussion below)
PHC F3 Aromatic	0.31
PHC F4 Aliphatic	NC (see discussion below)
PHC F4 Aromatic	0.03 <sup>c</sup>

Note:

<sup>a</sup>  $K_p$  values from U.S. EPA (2004, Exhibit 3.1, or Appendix B-2 predicted  $K_p$  values).

<sup>b</sup>  $K_p$  for PCB-chlorobiphenyl,4.

\* US EPA 2009: default value for inorganics used for organics that are always ionized, and ionized species of ionizable organic chemicals.

The dermal exposure pathway for PHC in the aliphatic F3 and F4 fraction was not evaluated in this assessment because the characteristics of these compounds are well outside the range for application of the methodology provided by the U.S. EPA (2004) and discussed above. Dermal exposure from groundwater is not expected to be a significant route of exposure for PHC F3 as CCME (2000) which indicated that dermal absorption decreases with increasing carbon number. In addition, ATSDR (1999) reviewed the potential effects of dermal exposure for many petroleum hydrocarbons and found that effects may be present from exposure to benzene and PAHs, but for other compounds with higher carbon content, there may be irritation but there was little evidence to suggest systemic toxicity.

### 5.2.7.6 Inhalation

In general, the non-radiological dose from inhalation (of outdoor air, or dust/particulate in air) is calculated for each COPC, following Equation 5-23, consistent with CSA (2012). Equation 5-23 calculates a dose in mg/kg-d that is compared to a slope factor or reference dose TRV (depending on carcinogenic effects for a particular COPC). However, for many chemical compounds, TRVs for the inhalation pathway are expressed as reference concentrations (in mg/m<sup>3</sup>). In such cases, Equation 5-24 is used to calculate exposure:

$$D_{sp} = \frac{C_s \times P_{air} \times IR_a \times AF_{INH} \times D_1 \times D_2 \times D_3 \times D_4}{BW \times LE} \quad (5-23)$$

Where:

- $D_{sp}$  = dose from inhalation of soil dust/particulate [mg/kg/d]
- $C_s$  = concentration of COPC in soil [mg/kg]
- $P_{air}$  = particulate concentration in air [kg/m<sup>3</sup>]
- $IR_a$  = receptor air inhalation rate [m<sup>3</sup>/d]
- $AF_{INH}$  = absorption factor for inhalation (assumed equal to 1) [unitless]
- $D_1$  = hours per day exposed, divided by 24 hours [hr/hr]
- $D_2$  = days per week exposed, divided by 7 days [d/d]
- $D_3$  = weeks per year exposed, divided by 52 weeks [wk/wk]
- $D_4$  = total years exposed to site (for carcinogens only) [yr]
- $BW$  = receptor body weight [kg]
- $LE$  = Life expectancy (for carcinogens only) [yr]

$$D_{sp} = \frac{C_s \times P_{air} \times D_1 \times D_2 \times D_3 \times D_4}{LE} \quad (5-24)$$

Where:

- $D_i$  = exposure from inhalation [ $\text{mg}/\text{m}^3$ ]
- $C_s$  = concentration of COPC in soil [ $\text{mg}/\text{kg}$ ]
- $P_{air}$  = particulate concentration in air [ $\text{kg}/\text{m}^3$ ]
- $D_1$  = hours per exposure event, divided by 24 hours [ $\text{hr}/\text{hr}$ ]
- $D_2$  = days per week exposed, divided by 7 days [ $\text{d}/\text{d}$ ]
- $D_3$  = weeks per year exposed, divided by 52 weeks [ $\text{wk}/\text{wk}$ ]
- $D_4$  = total years exposed to site (for carcinogens only) [ $\text{yr}$ ]
- $LE$  = Life expectancy (for carcinogens only) [ $\text{yr}$ ]

In the absence of measured air concentrations, concentrations of COPCs associated with particulate in ambient air can be estimated from soil data using an assumed respirable ( $\leq 10 \mu\text{m}$  aerodynamic diameter) particulate concentration. For maintenance and sub-surface workers who may be exposed to a higher concentration of particulates as a result of soil resuspension during typical activities, a respirable particulate concentration of  $60 \mu\text{g}/\text{m}^3$  (or  $6.0 \times 10^{-8} \text{ kg}/\text{m}^3$ ) is typically used (MOE 2009). For all other receptors, a value of  $0.76 \mu\text{g}/\text{m}^3$  (or  $7.6 \times 10^{-10} \text{ kg}/\text{m}^3$ ) as provided by Health Canada (2004) is typically used for areas with no construction activities.

In this study, air concentrations at each off-site receptor location have been estimated using air modelling (see Section 3.1). Therefore, the air inhalation calculation for the off-site receptors replaces  $C_s$  ( $\text{mg}/\text{kg}$ ) and  $P_{air}$  ( $\text{kg}/\text{m}^3$ ) in Equation 5-24 with the modeled air concentration (in  $\mu\text{g}/\text{m}^3$ ), with the appropriate unit conversion. The amount of time spent outdoors (and therefore exposed to the air concentrations) is assumed to be 3.5 hours per day (based on HC 2010, with an additional 2h/d for swimming, gardening, etc. See Section 5.2).

#### 5.2.7.7 Inhalation of Vapours

The non-radiological dose from inhalation of vapours from soil or groundwater is calculated for each COPC, following Equation 5-25, consistent with CSA (2012). Equation 5-25 calculates a dose in  $\text{mg}/\text{kg}\text{-d}$  that is compared to a slope factor or reference dose TRV (depending on carcinogenic effects). However, for many chemical compounds, TRVs for the inhalation pathway are expressed as reference concentrations (in  $\text{mg}/\text{m}^3$ ). In such cases, Equation 5-26 is used to calculate exposure:

$$D_v = \frac{C_a \times IR_a \times AF_{INH} \times D_1 \times D_2 \times D_3 \times D_4}{BW \times LE} \quad (5-25)$$

Where:

- $D_v$  = dose from inhalation of vapours [mg/kg/d]
- $C_a$  = concentration of COPC in air (i.e., vapour concentration) [mg/m<sup>3</sup>]
- $IR_a$  = receptor air inhalation rate [m<sup>3</sup>/d]
- $AF_{INH}$  = absorption factor for inhalation (assumed equal to 1) [unitless]
- $D_1$  = hours per day exposed, divided by 24 hours [hr/hr]
- $D_2$  = days per week exposed, divided by 7 days [d/d]
- $D_3$  = weeks per year exposed, divided by 52 weeks [wk/wk]
- $D_4$  = total years exposed to site (for carcinogens only) [yr]
- $BW$  = receptor body weight [kg]
- $LE$  = Life expectancy (for carcinogens only) [yr]

$$D_v = \frac{C_a \times D_1 \times D_2 \times D_3 \times D_4}{LE}$$

(5-26)

Where:

- $D_v$  = exposure from inhalation of vapours [mg/m<sup>3</sup>]
- $C_a$  = concentration of COPC in air (i.e., vapour concentration) [mg/m<sup>3</sup>]
- $D_1$  = hours per exposure event, divided by 24 hours [hr/hr]
- $D_2$  = days per week exposed, divided by 7 days [d/d]
- $D_3$  = weeks per year exposed, divided by 52 weeks [wk/wk]
- $D_4$  = total years exposed to site (for carcinogens only) [yr]
- $LE$  = Life expectancy (for carcinogens only) [yr]

## 5.2.8 Exposure Calculation Results

Prior to calculating risk to the human receptors, radiological and non-radiological dose estimates were calculated. In Section 5.4 below, these estimated doses are compared to toxicity or radiological benchmarks, in order to estimate risk.

### 5.2.8.1 Non-Radiological Dose Estimates

Due to their large volume, the non-radiological dose estimation results have been consolidated and documented separately [REDACTED]. The radiological doses, which are more concise, are presented below.

### 5.2.8.2 Radiological (Radionuclide) Dose Estimates

[REDACTED]. A summary of the Tier 1 results is presented in Table 5.15. These values do not include external gamma dose, which is added later in the calculation (see Section 5.2.8.4).

Table 5.15 HHRA – Tier 1 Radionuclide Dose Estimates (in mSv/y)

Radionuclide	Commercial Worker	Fisherman	Yacht Club User	Fenceline Walker	Park User			Resident			Commercial Worker + Resident	Fenceline Walker + Resident	Yacht Club Member + Resident	Fisher person + Resident	Park User + Resident
					Adult	Child	Infant	Adult	Child	Infant					
Pb-210	ND	1.77E-02	6.91E-07	ND	ND	ND	ND	1.77E-02	3.71E-02	ND	ND	ND	1.77E-02	3.54E-02	ND
Po-210	ND	4.43E-03	1.20E-07	ND	ND	ND	ND	4.43E-03	1.07E-02	ND	ND	ND	4.43E-03	8.86E-03	ND
Ra-224	ND	2.67E-05	6.51E-09	ND	ND	ND	ND	2.67E-05	7.03E-05	ND	ND	ND	2.67E-05	5.33E-05	ND
Ra-226	ND	1.26E-03	3.10E-07	ND	ND	ND	ND	1.39E-03	2.75E-03	4.45E-04	ND	ND	1.39E-03	2.66E-03	ND
Ra-228	ND	2.83E-04	6.98E-08	ND	ND	ND	ND	2.83E-04	1.05E-03	ND	ND	ND	2.83E-04	5.66E-04	ND
Th-228	ND	8.43E-05	1.38E-08	ND	ND	ND	ND	8.43E-05	1.66E-04	ND	ND	ND	8.43E-05	1.69E-04	ND
Th-230	ND	1.29E-04	2.10E-08	ND	ND	ND	ND	1.29E-04	1.26E-04	ND	ND	ND	1.29E-04	2.58E-04	ND
Th-232	ND	1.42E-04	2.30E-08	ND	ND	ND	ND	1.42E-04	1.18E-04	ND	ND	ND	1.42E-04	2.83E-04	ND
U-234	3.74E-04	2.93E-04	2.38E-04	5.87E-05	1.78E-05	2.17E-04	4.18E-04	2.89E-03	3.85E-03	2.84E-03	3.26E-03	2.95E-03	3.13E-03	3.18E-03	2.91E-03
U-235	1.52E-05	1.43E-05	9.71E-06	2.39E-06	7.83E-07	9.69E-06	1.94E-05	1.26E-04	1.69E-04	1.253E-04	1.41E-04	1.28E-04	1.36E-04	1.40E-04	1.27E-04
U-238	3.10E-04	2.50E-04	1.97E-04	4.86E-05	7.38E-03	7.59E-03	1.00E-02	1.59E-01	1.60E-01	2.06E-01	1.59E-01	1.59E-01	1.59E-01	1.59E-01	1.66E-01
<b>Total (mSv/y)</b>	<b>6.99E-04</b>	<b>2.46E-02</b>	<b>4.46E-04</b>	<b>1.10E-04</b>	<b>7.40E-03</b>	<b>7.81E-03</b>	<b>1.05E-02</b>	<b>1.86E-01</b>	<b>2.16E-01</b>	<b>2.09E-01</b>	<b>1.62E-01</b>	<b>1.62E-01</b>	<b>1.86E-01</b>	<b>2.11E-01</b>	<b>1.69E-01</b>

ND –data not available.

In Section 5.4, the estimated Tier 1 doses above are compared to the public dose limit of 1 mSv/y.

### 5.2.8.3 Gamma Dose Estimates

Two methods for estimating gamma dose at human receptor locations are shown [REDACTED]. Method 1 is based on MicroShield calculations and is generally conservative. Method 2 is based on a combination of TLD measurements and MicroShield calculations, and is more realistic. The results of Method 2 were used in the HHRA calculations, and are summarized in Table 5.16. These estimated dose rates are considered “incremental” in that they represent the dose associated with PHCF and Dorset Street sources.

In these Tier 1 calculations, residents were assigned the maximum estimated dose rate for any residential receptor (which in this case was the residence near Dorset Street). Yacht club users were assigned the highest estimated dose rate of either the PHCF side or Center Pier side (which in this case was in the Turning Basin closer to the PHCF side). Commercial workers were assigned the maximum estimated dose rate for any commercial worker (which in this case was the commercial worker near Dorset Street).

Table 5.16 Tier 1 Gamma Dose Rates for Human Receptors

Receptor	Assoc. T1 Gamma Dose Rate	Dose Rate Description
	(uSv/yr)	
Resident - Hayward	105	highest dose rate among the resident receptors (from RK3, Dorset Resident location)
Resident - Madison	105	highest dose rate among the resident receptors (from RK3, Dorset Resident location)
Resident - Dorset	105	highest dose rate among the resident receptors (from RK3, Dorset Resident location)
Yacht/Boater - PHCF side	80.5	highest dose rate of the yacht/boater receptors (RYEX3 - Turning Basin)
Yacht/Boater - CP side	80.5	highest dose rate of the yacht/boater receptors (RYEX3 - Turning Basin)
Park User	58.6	highest dose rate of the park receptors (EK1, Centre Pier)
Fenceline Walker	12.7	average dose rate over all fenceline locations
Fisher	267	highest dose rate among the fisher receptors (RFED2)
Commercial Worker – Downtown	47.5	highest dose rate of all commercial worker receptors (CK1, near Dorset E)
Commercial Worker – By Bldg 50	47.5	highest dose rate of all commercial worker receptors (CK1, near Dorset E)
Commercial Worker – By CentrePier	47.5	highest dose rate of all commercial worker receptors (CK1, near Dorset E)
Commercial Worker – By Dorset	47.5	highest dose rate of all commercial worker receptors (CK1, near Dorset E)
Commercial Worker + Resident	152.5	Sum of the highest commercial worker dose rate and highest resident dose rate
Fenceline Walker + Resident	117.7	Sum of the highest fenceline walker dose rate and highest resident dose rate
Park User + Resident	163.6	Sum of the highest park user dose rate and highest resident dose rate
Fisher + Resident	372	Sum of the highest fisherperson dose rate and highest resident dose rate
Yacht Club Member + Resident	185.5	Sum of the highest yacht club member dose rate and highest resident dose rate

The above modelled gamma dose rates were added to the estimated doses from individual radionuclides, in order to generate an estimated total dose.



## 5.3 Toxicity Assessment

### 5.3.1 Non-Radiological COPCs – Toxicological Reference Values

Exposure to non-radionuclides is conventionally assessed against Toxicity Reference Values (TRVs). Toxicity is the potential of a chemical to cause some type of damage, either permanent or temporary, to the structure or functioning of any part of the body. The toxicity depends on the amount of the chemical taken into the body (generally termed the intake or dose) and the length of time a person is exposed. Every chemical has a specific dose and duration of exposure that is necessary to produce a toxic effect in humans. Toxicity assessments generally involve the evaluation of scientific studies, based either on laboratory animal tests or on workplace exposure investigations, by a number of experienced scientists in a wide range of scientific disciplines in order to determine the maximum dose that a human can be exposed to without having an adverse health effect.

Toxicity assessments generally categorize adverse effects as short term (acute) or long term (chronic). This study focuses on the assessment of long term (chronic) effects.

#### *Carcinogenic TRVs*

Carcinogenesis is generally assumed to be a "non-threshold" type phenomenon whereby it is assumed that any level of exposure to a carcinogen poses a finite probability of generating a carcinogenic response. Carcinogenic TRVs or slope factors are used to estimate an upper-bound lifetime probability of an individual developing cancer as a result of exposure to a particular level of a potential carcinogen. The carcinogenic TRV is, therefore, the incremental lifetime cancer risk per unit of dose.

#### *Non Carcinogenic TRVs*

For many non-carcinogenic effects, protective biological mechanisms must be overcome before an adverse effect from exposure to the chemical is manifested. For this reason, scientists generally agree that there is a level (threshold) below which no adverse effects would be measurable or expected to occur. This is known as a "threshold" concept. Non-carcinogens are often referred to as "systemic toxicants" because of their effects on the function of various organ systems. These toxicity reference values are generally called reference doses (RfDs), tolerable daily intakes (TDIs) or acceptable daily intakes (ADIs) and are generally derived by regulatory agencies such as Health Canada and the United States Environmental Protection Agency (U.S. EPA). These TRVs are usually expressed as the quantity of a chemical per unit body weight per unit time (mg/kg-day) or as an air concentration (mg/m<sup>3</sup>) and have generally been derived for sensitive individuals in the public using the most sensitive endpoint available. These factors involve the incorporation of "uncertainty factors" by regulatory agencies to provide protection for members of the public.

There are several regulatory sources that report TRVs for evaluation of effects from long-term (i.e., chronic) exposure. The main sources used in this study are:

1. Health Canada;
2. Ontario Ministry of Environment (OMOE) – *citing CalEPA, IRIS, RIVM and others*;
3. Canadian Council of Ministers of the Environment (CCME);

4. US California EPA (CalEPA);
5. U.S. EPA Integrated Risk Information System (IRIS) database;
6. World Health Organization (WHO);
7. Netherlands National Institute of Public Health and the Environment (RIVM); and
8. Agency for Toxic Substances and Disease Registry (ATSDR).

Table 5.17 presents the human-health TRVs selected for use in this assessment.

Final – Environmental Risk Assessment for the Cameco Port Hope Conversion Facility

Table 5.17 HHRA – TRVs

COPC	Pathway of Exposure*	Carc. vs. Non-Carc.**	Value	Units	Health Effect	Ref
Ammonia	Oral	-	-	-	See discussion below	-
	Inh.	Non-carc.	0.07	mg/m <sup>3</sup>	Pulmonary function	ATSDR (2004b)
Ag	Oral	non-carc	5 x 10 <sup>-3</sup>	mg/(kg-d)	Skin effects, discolouration (argyria). Increased silver-induced production of melanin.	US EPA IRIS (online 2015).
Al	Oral	non-carc	1.0	mg/(kg-d)	Neurotoxicity,	US EPA PPRTV (US EPA 2006)
	Inhalation	non-carc	5 x 10 <sup>-3</sup>	mg/m <sup>3</sup>	Neurotoxicity,	
As	oral	carc.	1.8	(mg/kg-d) <sup>-1</sup>	Internal cancers (liver, lung, bladder, kidney)	HC (2012b)
	oral	non-carc.	3 x 10 <sup>-4</sup>	mg/(kg-d)	Hyperpigmentation, keratosis and possible vascular complications	US EPA IRIS (online 2015)
	inhalation	carc.	6.4	(mg/m <sup>3</sup> ) <sup>-1</sup>	Lung cancer	HC (2012b)
	inhalation	non-carc.	1.5x10 <sup>-5</sup>	mg/m <sup>3</sup>	Development; cardiovascular system; nervous system; respiratory system; skin	CalEPA (2008); updated since MOE (2011)
B	oral	non-carc	1.75 x 10 <sup>-2</sup>	mg/(kg-d)	Testicular atrophy resulting in infertility and spermatogenic arrest	HC (2012b)
	inhalation	non-carc	2 x 10 <sup>-2</sup>	mg/m <sup>3</sup>	Respiratory tract effects, bronchitis, irritation.	EPA RSLs – HEAST (1997)
Ba	oral	non-carc	2 x 10 <sup>-1</sup>	mg/(kg-d)	Renal lesions in mice	HC (2012b)
	inhalation	non-carc	1 x 10 <sup>-3</sup>	mg/m <sup>3</sup>	Cardiovascular effects, hypertension, hearth arrhythmia. Also respiratory and renal effects in animal tests.	MOE (2011): (RIVM 2001)
Bromide	n/a; see discussion following table					
Ca	n/a; see discussion following table					
Cd	oral	non-carc	1 x 10 <sup>-3</sup>	mg/(kg-d)	Significant proteinuria (chronic human exposure)	HC 2012b
	inhalation	carc.	42	(mg/kg-d) <sup>-1</sup>	Internal cancers (lungs)	Health Canada 2012b
	inhalation	carc.	9.8	(mg/m <sup>3</sup> ) <sup>-1</sup>	Internal cancers (lungs)	Health Canada 2012b
	inhalation	non-carc.	3.0x10 <sup>-5</sup>	mg/m <sup>3</sup>	Kidney effects	MOE (2011): based on 24-hour AAQC from MOE 2007
Co	oral	non-carc.	1 x 10 <sup>-2</sup>	mg/(kg-d)	Haematological effects (polycythemia)	ATSDR (2004a)

Final – Environmental Risk Assessment for the Cameco Port Hope Conversion Facility

COPC	Pathway of Exposure*	Carc. vs. Non-Carc.**	Value	Units	Health Effect	Ref
	inhalation	non-carc.	5.0x10 <sup>-4</sup>	mg/m <sup>3</sup>	Interstitial lung disease	OMOE (2011): <i>RIVM (2001)</i>
Chloride	n/a; see discussion following table					
Cr	oral	non-carc.	1 x 10 <sup>-3</sup>	mg/(kg-d)	Hepatotoxicity. Corrosion of the gastrointestinal tract mucosa. Encephalitis.	HC (2012b)
	inhalation	carc.	1.1 x 10 <sup>1</sup>	(mg/m <sup>3</sup> ) <sup>-1</sup>	Lung cancer	
	inhalation	carc.	4.6 x 10 <sup>e</sup>	(mg/kg-d) <sup>-1</sup>	Lung cancer	
Cu	Oral (age-specific)	non-carc.	0-0.5 y 9.1x10 <sup>-2</sup>	mg/(kg-d)	Liver function impairment. Gastrointestinal tract effects.	HC (2012b)
			0.6-4 y 9.1x10 <sup>-2</sup>			
			5-11 y 1.1x10 <sup>-1</sup>			
			12-19 y 1.26x10 <sup>-1</sup>			
			19+ y 1.41x10 <sup>-1</sup>			
	inhalation	non-carc.	-	-	-	-
F	oral	non-carc.	1.05x10 <sup>-1</sup>	mg/(kg-d)	dental fluorosis	HC (2012b)
	inhalation	non-carc.	1.3x10 <sup>-2</sup>	mg/m <sup>3</sup>	Fluorosis; bones & teeth, respiratory system	CalEPA (2008) (accessed 2014)
K	n/a; see discussion following table					
Mg	n/a; see discussion following table					
Mn	Oral (age-specific)	non-carc.	0-0.5 y 1.36x10 <sup>-1</sup>	mg/(kg-d)	Neurotoxicity (Parkinsonian-like)	HC (2012b)
			0.6-4 y 1.36x10 <sup>-1</sup>			
			5-11 y 1.22x10 <sup>-1</sup>			
			12-19 y 1.42x10 <sup>-1</sup>			
			19+ y 1.56x10 <sup>-1</sup>			
Mo	Oral (age-specific)	non-carc.	0-0.5 y 2.3x10 <sup>-2</sup>	mg/(kg-d)	Reproductive effects	HC (2012b)***
			0.6-4 y 2.3x10 <sup>-2</sup>			
			5-11 y 2.3x10 <sup>-2</sup>			
			12-19 y 2.7x10 <sup>-2</sup>			
			19+ y 2.8x10 <sup>-2</sup>			
Na	n/a; see discussion following table					
Ni	oral	non-carc.	1.1x10 <sup>-2</sup>	mg/(kg-d)	Decreased body and organ weight (rat)	HC (2012b)

Final – Environmental Risk Assessment for the Cameco Port Hope Conversion Facility

COPC	Pathway of Exposure*	Carc. vs. Non-Carc.**	Value	Units	Health Effect	Ref
(assumed soluble form)	inhalation	carc.	0.71	(mg/m <sup>3</sup> ) <sup>-1</sup>	Lung cancer from exposure to nickel refinery dust	HC (2012b)
P (elemental)	n/a; see discussion following table					
Nitrate	oral	non-carc.	1.6	mg/(kg-d)	Methemoglobinemia, cyanosis	US EPA IRIS (online 2015).
Nitrite	oral	non-carc.	1 x 10 <sup>-1</sup>	mg/(kg-d)	Haematic effects, oxidation of hemoglobin to methemoglobin.	US EPA IRIS (online 2015).
Nitrate & Nitrite (based on nitrite; lowest)	See nitrite					
Pb	oral	non-carc.	1.85x10 <sup>-3</sup>	mg/(kg-d)	Neurological effects	OMOEE (1994)
	Inhalation	non-carc.	6.48x10 <sup>-3</sup>	mg/m <sup>3</sup>	Neurological effects	Derived based on OMOEE (1994), using inhalation rate of 20 m <sup>3</sup> /day and body weight of 70kg.
Sb (assumed trioxide form for inhalation TRV)	oral	non-carc.	4 x 10 <sup>-4</sup>	mg/(kg-d)	Longevity, blood glucose and cholesterol levels (rat)	OMOE (2011): US EPA IRIS (1991)
	inhalation	non-carc.	2.4x10 <sup>-4</sup>	mg/m <sup>3</sup>	-	OMOE (2011) (no longer in US EPA IRIS; 2014)
Se	Oral (age-specific)	non-carc.	5.5 x 10 <sup>-3</sup>	mg/(kg-d)	Clinical selenosis (human)	HC (2012b)***
			6.2 x 10 <sup>-3</sup>			
			6.3 x 10 <sup>-3</sup>			
			6.2 x 10 <sup>-3</sup>			
	5.7 x 10 <sup>-3</sup>					
inhalation	non-carc.	2.0x10 <sup>-2</sup>	mg/m <sup>3</sup>	Selenosis; liver, cardiovascular system, nervous system effects	CalEPA (2008) (accessed 2014)	
Sr	oral	non-carc.	1.3 x 10 <sup>-1</sup>	mg/(kg-d)	-	WHO (2010)
	inhalation	-	-	-	-	-
U	oral	non-carc.	6 x 10 <sup>-4</sup>	mg/(kg-d)	Degenerative lesions in kidney tubules	HC (2012b)
	inhalation	non-carc.	4.0x10 <sup>-5</sup>	mg/m <sup>3</sup>	Kidney effects	ATSDR 2013 (more recent than OMOE 2011)
V	oral	non-carc.	2.1 x 10 <sup>-3</sup>	mg/(kg-d)	Decreased body weight in test rats. Malformations (e.g. cleft palate) in test rats.	OMOE (2011): CalEPA (2000)
	inhalation	non-carc.	1 x 10 <sup>-3</sup>	mg/m <sup>3</sup>	Respiratory effects, bronchitis, pneumotitis.	OMOE (2011): WHO (2000)
Zn	Oral (age-specific)	non-carc.	0–0.5 y 4.9 x 10 <sup>-1</sup>	mg/kg-d		HC (2012b)

Final – Environmental Risk Assessment for the Cameco Port Hope Conversion Facility

COPC	Pathway of Exposure*	Carc. vs. Non-Carc.**	Value	Units	Health Effect	Ref
			0.6–4 y 4.8 x 10 <sup>-1</sup>		Adverse effect of excess zinc on copper metabolism	
			5–11 y 4.8 x 10 <sup>-1</sup>			
			12–19 y 5.4 x 10 <sup>-1</sup>			
			19+ y 5.7 x 10 <sup>-1</sup>			
	inhalation	-	-	-	-	-
Total Dissolved Solids (TDS)	n/a; see discussion following table					
Phosphate	n/a; see discussion following table					
Sulphate	n/a; see discussion following table					
PHC F1 Aliphatic C6-C8	oral	non-carc.	5	mg/kg-d	Neurotoxicity (C <sub>6</sub> -C <sub>8</sub> fraction).	OMOE (2011): TPHCWG (1997), CCME (2000)
	Inh.	non-carc.	1 x 10 <sup>-1</sup>	mg/m <sup>3</sup>		
PHC F1 Aliphatic C8-C10	oral	non-carc.	1 x 10 <sup>-1</sup>	mg/kg-d	Hepatic and haematological changes (C <sub>8</sub> -C <sub>10</sub> fraction).	OMOE (2011): TPHCWG (1997), CCME (2000)
	Inh	non-carc.	1.0	mg/m <sup>3</sup>		
PHC F1 Aromatic C8-C10	oral	non-carc.	4.0 x 10 <sup>-2</sup>	mg/kg-d	Decreased body weight (C <sub>8</sub> -C <sub>10</sub> fraction).	OMOE (2011): TPHCWG (1997), CCME (2000)
	inh	non-carc.	2.0 x 10 <sup>-1</sup>	mg/m <sup>3</sup>		
PHC F2 Aliphatic C10-C12	oral	non-carc.	1 x 10 <sup>-1</sup>	mg/kg-d	Hepatic and haematological changes	OMOE (2011): TPHCWG (1997), CCME (2000)
	inhalation	non-carc.	1	mg/m <sup>3</sup>		
PHC F2 Aromatic C10-C12	oral	non-carc.	4 x 10 <sup>-2</sup>	mg/kg-d	Decreased body weight	OMOE (2011): TPHCWG (1997), CCME (2000)
	inhalation	non-carc.	2x10 <sup>-1</sup>	mg/m <sup>3</sup>		
PHC F2 Aliphatic C12-C16	oral	non-carc.	1 x 10 <sup>-1</sup>	mg/kg-d	Hepatic and haematological changes	OMOE (2011): TPHCWG (1997), CCME (2000)
	inhalation	non-carc.	1	mg/m <sup>3</sup>		
PHC F2 Aromatic C12-C16	oral	non-carc.	4 x 10 <sup>-2</sup>	mg/kg-d	Decreased body weight	OMOE (2011): TPHCWG (1997), CCME (2000)
	inhalation	non-carc.	2x10 <sup>-1</sup>	mg/m <sup>3</sup>		
PHC F3 Aliphatic C16-C21	oral	non-carc.	2.0	mg/kg-d	Hepatic (foreign body) Granuloma	OMOE (2011): TPHCWG (1997), CCME (2000)
	inhalation	--	--			
PHC F3 Aromatic C16-C21	oral	non-carc.	3x10 <sup>-2</sup>	mg/kg-d	Nephrotoxicity	OMOE (2011): TPHCWG (1997), CCME (2000)
	inhalation	--	--			

Final – Environmental Risk Assessment for the Cameco Port Hope Conversion Facility

COPC	Pathway of Exposure*	Carc. vs. Non-Carc.**	Value	Units	Health Effect	Ref
PHC F3 Aliphatic C21-C34	oral	non-carc.	2.0	mg/kg-d	Hepatic (foreign body) Granuloma	OMOE (2011): TPHCWG (1997), CCME (2000)
	inhalation	--	--			
PHC F3 Aromatic C21-C34	oral	non-carc.	3x10 <sup>-2</sup>	mg/kg-d	Nephrotoxicity	OMOE (2011): TPHCWG (1997), CCME (2000)
	inhalation	--	--			
PHC F4 Aliphatic C>34	oral	non-carc	20	mg/kg-d	Hepatic (foreign body) Granuloma	OMOE (2011): TPHCWG (1997), CCME (2000)
	inhalation	--	--			
PHC F4 Aromatic C>34	oral	non-carc.	3x10 <sup>-2</sup>	mg/kg-d	Nephrotoxicity	OMOE (2011): TPHCWG (1997), CCME (2000)
	Inhalation	--	--			
Benzene	oral	non-carc.	4 x 10 <sup>-3</sup>	mg/kg-d	Haematological effects (decreased lymphocyte count)	OMOE (2011): US EPA IRIS (2003)
	oral	carc.	8.34x10 <sup>-2</sup>	(mg/kg-d) <sup>-1</sup>	Malignant lymphomas, bone marrow; hematopoietic hyperplasia	HC (2012b)
	inhalation	non-carc.	3x10 <sup>-2</sup>	mg/m <sup>3</sup>	Haematological effects (decreased lymphocyte count)	OMOE (2011): US EPA IRIS (2003)
	inhalation	carc.	3.3x10 <sup>-3</sup>	(mg/m <sup>3</sup> ) <sup>-1</sup>	Hematotoxicity	HC (2012b)
Carbon Tetrachloride	oral	non-carc.	4 x 10 <sup>-3</sup>	mg/kg-d	Hepatic effects (elevated serum SDH activity)	US EPA IRIS (2010); more recent than Health Canada (2012b) and OMOE (2011) values.
	inhalation	non-carc.	1 x 10 <sup>-1</sup>	mg/m <sup>3</sup>	Hepatic effects (fatty changes in the liver)	US EPA IRIS (2010); more recent than Health Canada (2012b) and OMOE (2011) values.
	inhalation	carc.	7 x 10 <sup>-2</sup>	(mg/kg-d) <sup>-1</sup>	Hepatocellular adenoma or carcinoma	
	inhalation	carc.	6 x 10 <sup>-3</sup>	(mg/m <sup>3</sup> ) <sup>-1</sup>	Pheochromocytoma	
Chloroform	oral	non-carc.	1 x 10 <sup>-2</sup>	mg/kg-d	Hepatic effects (fatty cyst formation in the liver and elevated SGPT)	OMOE (2011): US EPA IRIS (2001)
	oral	carc.	<i>No longer considered to be carcinogenic by Health Canada</i>			
	inhalation	non-carc.	9.8 x 10 <sup>-2</sup>	mg/m <sup>3</sup>	Hepatic effects in workers (hepatomegaly)	OMOE (2011): ASTDR (1997)
	inhalation	carc.	<i>No longer considered to be carcinogenic by Health Canada</i>			
Dichlorodifluorom ethane	Oral	non-carc.	2 x 10 <sup>-1</sup>	mg/kg-d	Decreased body weight in test rats	OMOE (2011): US EPA IRIS (online 2015)

Final – Environmental Risk Assessment for the Cameco Port Hope Conversion Facility

COPC	Pathway of Exposure*	Carc. vs. Non-Carc.**	Value	Units	Health Effect	Ref
Ethylbenzene	oral	non-carc.	$1 \times 10^{-1}$	mg/kg-d	Liver and kidney toxicity	HC (2012b)
	inhalation	non-carc.	1	mg/m <sup>3</sup>	Developmental toxicity	HC (2012b)
Ethylene-dibromide	oral	non-carc.	$9.0 \times 10^{-3}$	mg/kg-d	Testicular atrophy, liver peliosis, adrenal cortical degeneration.	HC (2012b)
	inhalation	non-carc.	$9.3 \times 10^{-3}$	mg/m <sup>3</sup>	Nasal inflammation, hepatic necrosis, testicular and retinal atrophy, adrenal cortical degeneration, splenic hematopoiesis	
	oral	carc.	2.0	(mg/kg-d) <sup>-1</sup>	Stomach squamous cell carcinoma, hemangiosarcoma, thyroid follicular cell adenoma, hepatocellular carcinoma, lung adenomas.	
	inhalation	carc.	$6.0 \times 10^{-1}$	(mg/m <sup>3</sup> ) <sup>-1</sup>	Nasal cavity tumours, hemangiosarcoma, mesotheliomas.	
1,1-Dichloro-ethylene	oral	non-carc.	$3 \times 10^{-3}$	mg/kg-d	Hepatotoxicity	HC (2012b)
	inhalation	non-carc.	$7 \times 10^{-2}$	mg/m <sup>3</sup>	Hepatotoxicity	OMOE (2011): CalEPA (2000)
cis-1,2-Dichloro-ethylene	oral	non-carc.	$2 \times 10^{-3}$	mg/kg-d	Increased relative kidney weight	US EPA IRIS (2010); more recent than Health Canada (2012b) and OMOE (2011) values.
	inhalation	non-carc.	$1.5 \times 10^{-1}$	mg/m <sup>3</sup>	Decreased body weight, haemoglobin and hematocrit	OMOE (2011): adapted from RIVM 2001
Trans-1,2-Dichloro-ethylene	oral	non-carc.	$2 \times 10^{-2}$	mg/kg-d	Decrease in number of ant body forming cells against sheep red blood cells	US EPA IRIS (2010); more recent than Health Canada (2012b) and OMOE (2011) values.
	inhalation	non-carc.	$6.0 \times 10^{-2}$	mg/m <sup>3</sup>	Lung and liver effects	OMOE (2011): RIVM (2001)
Trichloro-ethene	oral	carc.	$4.6 \times 10^{-2}$	(mg/kg-d) <sup>-1</sup>	Tubular cell adenomas, adenocarcinomas of the kidneys	US EPA IRIS (2011); more recent than Health Canada (2012b) and OMOE (2011) values.
	oral	non-carc.	$5 \times 10^{-4}$	(mg/kg-d)	Immunotoxicity and heart malformations	
	Inhalation	non-carc.	$2.0 \times 10^{-3}$	mg/m <sup>3</sup>	Immunotoxicity and heart malformations	



Final – Environmental Risk Assessment for the Cameco Port Hope Conversion Facility

COPC	Pathway of Exposure*	Carc. vs. Non-Carc.**	Value	Units	Health Effect	Ref
	inhalation	carc.	$4.8 \times 10^{-3}$	$(\text{mg}/\text{m}^3)^{-1}$	Leydig cell tumours in testes	
Vinyl chloride	oral	carc.	$2.6 \times 10^{-1}$	$(\text{mg}/\text{kg}\cdot\text{d})^{-1}$	Hepatocellular angiosarcomas, and carcinomas	HC (2012b)
	oral	non-carc.	$3 \times 10^{-3}$	mg/kg-d	Liver alterations and histopathology (liver cell polymorphism)	OMOE (2011): <i>US EPA IRIS 2000</i>
	inhalation	carc.	$8.8 \times 10^{-3}$	$(\text{mg}/\text{m}^3)^{-1}$	Liver (liver angiosarcomas, angiomas, hepatomas and neoplastic nodules)	OMOE (2011): <i>US EPA IRIS 2000</i>
	inhalation	carc.	1.4	$(\text{mg}/\text{kg}\cdot\text{d})^{-1}$	Liver (liver angiosarcomas, angiomas, hepatomas and neoplastic nodules)	OMOE (2011): <i>adapted from US EPA IRIS (2000)</i>
	inhalation	non-carc.	$1 \times 10^{-1}$	$(\text{mg}/\text{m}^3)$	Liver alterations and histopathology (liver cell polymorphism)	OMOE (2011): <i>US EPA IRIS (2000)</i>
PCBs (total) (non dioxin-like)	oral	non-carc.	$1.3 \times 10^{-4}$	mg/kg-d	-	HC (2012b)
	oral	carc.	2.0	$(\text{mg}/\text{kg}\cdot\text{d})^{-1}$	Liver hepatocellular adenomas (rats)	US EPA IRIS (1997)
	inhalation	non-carc.	$5 \times 10^{-4}$	$(\text{mg}/\text{m}^3)$	Immunological effects in monkeys	OMOE (2011): <i>RIVM (2001)</i>
	inhalation	carc.	$1 \times 10^{-1}$	$(\text{mg}/\text{m}^3)^{-1}$	Liver cancers (rat)	OMOE (2011): <i>US EPA IRIS (1997)</i>

Notes:

- \* Dermal exposure was routinely evaluated using the oral TRV.
- \*\* Carcinogenic (non-threshold) vs. non-carcinogenic (threshold) effect.

The following COPCs were identified for a qualitative assessment/discussion, based on having no component value and no toxicological information:

- Ammonia;
- Bromide;
- Calcium
- Chloride;
- Magnesium;
- Phosphate;
- Phosphorus;
- Potassium;
- Sodium;
- Sulphate; and
- Total Dissolved Solids (TDS).

#### Ammonia

For ammonia, an inhalation TRV is available but an ingestion TRV is not. Therefore, ammonia ingestion pathways (which are applicable to off-site members of the public) can only be assessed qualitatively. Health Canada (2012) determined that it was not necessary to develop a drinking water ingestion guideline, as ammonia is produced in the body and efficiently metabolized in healthy people. Therefore, adverse effects are not expected from ammonia ingestion pathways.

Though an inhalation TRV is available for ammonia, inhalation of volatile ammonia is not an applicable pathway for off-site human receptors and does not require assessment.

#### Bromide

According to WHO (2009), bromide ion has a low degree of toxicity. An acceptable daily intake (ADI) based on a no-observed-effect level (NOEL) (for marginal effect within normal limits of electroencephalography, EEGs, in females) of 0.4 mg/kg body weight was determined and a drinking water value up to 2 mg/L was determined (WHO 2009). These values are much higher than typically found in the environment. Thus bromide was not carried forward for a quantitative assessment.

#### Calcium

The technical supporting document for the drinking water guideline development for calcium by Health Canada (1987a) states that because of the efficient homeostatic mechanisms that control calcium metabolism, adverse effects are observed only following the intake of extremely large quantities of calcium. Therefore, calcium was not carried forward for a quantitative assessment.

### Chloride

The technical supporting document for the drinking water guideline development for chloride by Health Canada (1987b) indicates that chloride concentrations in the body are well regulated through a complex interrelated system involving both nervous and hormonal systems. Even after intake of large quantities of chloride through food and water, the chloride balance is maintained, mainly by the excretion of excess chloride via the urine.

### Magnesium

Magnesium is an essential element in human metabolism and is required for over 300 enzyme reactions. The most readily observable adverse effect of magnesium in drinking water is the laxative effect (Health Canada 1987c).

### Phosphorus and Phosphate

CCME (2013) has confirmed that phosphorus does not pose a direct threat to human health; it is an essential component of all cells and is present in bones and teeth. The issue with phosphorus is as a nutrient that can affect water quality.

### Potassium

Potassium is an essential element that helps regulate fluid volumes in cells and is thus necessary to maintain normal cell function. Potassium also acts to blunt the risk of blood pressure in response to sodium and decreases markers of bone turnover and recurrence of kidney stones (Institute of Medicine, IOM 2004). There are no health effects noted from excessive consumption of food (IOM 2004) and thus the IOM did not derive an upper limit (maximum level of daily nutrient that is likely to pose no risk of health effects).

### Sodium

Sodium is not considered to be a toxic element (Health Canada 1992a). Up to 5 g/day of sodium is consumed by normal adults without apparent adverse effects.

### Sulphate

Sulphate is one of the least toxic anions (Health Canada 1994). A drinking water guideline was established based on aesthetic objectives.

### Total Dissolved Solids (TDS)

Total dissolved solids (TDS) comprise primarily inorganic salts that are dissolved in water. The principal constituents are usually the cations calcium, magnesium, sodium and potassium and the anions carbonate, bicarbonate, chloride, sulphate and potentially nitrate. These individual components were included in the assessment. No toxicity has been clearly linked with the presence of TDS (Health Canada 1992b). A drinking water guideline was established based on taste.

### 5.3.2 Radiological COPCs – Radiation Dose Limits

The radiological benchmarks used in this assessment are based on the dose limits in the Nuclear Safety and Control Act Radiation Protection Regulations (CNSC 2000, see Table 5.18). These benchmarks were compared to the estimated doses in order to characterize risk.

Table 5.18 HHRA – Radiological Benchmarks

Receptor	Dose Limit	Reference
Member of the public	1 mSv/y	CNSC (2000) - <i>Nuclear Safety and Control Act, Radiation Protection Regulations</i>

## 5.4 Risk Characterization

Risk characterization involves the integration of the information from the exposure assessment and the toxicity assessment.

### 5.4.1 Radiological Risk Characterization

Radiological risk characterization involves comparing the total estimated dose (per year) (from Section 5.2.8.2) to the dose limits outlined in Section 5.3.2. To facilitate identification of doses that exceed the dose limit, a screening index (SI) is calculated by dividing the estimated dose by the dose limit; in this way any resulting SI values greater than one represent a dose estimate that exceeds the dose limit.

### 5.4.2 Non-Radiological Risk Characterization

For this study, both non-carcinogens and carcinogens are included.

For many non-carcinogenic effects, protective biological mechanisms must be overcome before an adverse effect is manifested from exposure to the COPC. This is known as a "threshold" concept. For non-carcinogenic COPCs, the hazard quotient (HQ) is used to assess the potential for effects. Consistent with CSA (2012), HQs are calculated for threshold-acting chemicals on a *per medium basis*. It is important to note that TRVs specific to the dermal absorption pathway are largely not available. As such, oral toxicity data have been used as surrogates for the dermal pathway. Therefore it is appropriate to combine the oral and dermal exposures together (summed). In general, inhalation HQs are provided separately since effects resulting from inhalation exposure are generally for a different endpoint compared to the oral route. The inhalation HQs are summed with those from the oral and dermal pathways only if the endpoints for the different routes of exposure are the same. Overall, Equation 5-27 defines the HQ calculation procedure:

(5-27)

$$HQ_{OD_s} = \frac{D_{ING_s}}{TRV_o} + \frac{D_{DERMAL_s}}{TRV_d}$$

$$HQ_{OD_{gw}} = \frac{D_{ING_{gw}}}{TRV_o} + \frac{D_{DERMAL_{gw}}}{TRV_d}$$

$$HQ_i = \frac{D_{a,p} + D_{a,v}}{TRV_i}$$

Where:

HQ <sub>OD<sub>s</sub></sub>	=	HQ for oral ingestion (soil), including dermal contribution
HQ <sub>OD<sub>gw</sub></sub>	=	HQ for oral ingestion (groundwater), including dermal contribution
D <sub>ING<sub>s</sub></sub>	=	Dose from incidental soil ingestion
D <sub>ING<sub>gw</sub></sub>	=	Dose from incidental groundwater ingestion
D <sub>DERMAL<sub>s</sub></sub>	=	Dose from dermal exposure to soil
D <sub>DERMAL<sub>gw</sub></sub>	=	Dose from dermal exposure to groundwater
HQ <sub>o</sub>	=	Hazard quotient – oral exposure [-]
HQ <sub>i</sub>	=	Hazard quotient – inhalation exposure [-]
D <sub>a,p</sub>	=	Dose from airborne soil particulate
D <sub>a,v</sub>	=	Dose from airborne soil vapours
TRV <sub>i</sub>	=	Toxicity Reference Value for inhalation exposure (RfC) [mg/m <sup>3</sup> ]
TRV <sub>o</sub>	=	Toxicity Reference Value for oral exposure (RfD) [mg/(kg-d)]
TRV <sub>d</sub>	=	Toxicity Reference Value for dermal exposure [mg/(kg-d)]
		<i>(TRV<sub>d</sub> assumed equal to TRV<sub>o</sub>)</i>

When all pathways of exposure and background sources are considered, if the HQ is below a value of 1.0, no potential exists for an adverse effect for the selected receptor. However, in this assessment there are potential pathways of exposure from other sources that have not been included (e.g., natural background levels in water, store-bought food, household air, household dust, etc.). For this reason, the calculated HQ is compared to a more conservative value of 0.2, consistent with risk assessment practice (CSA 2012).

For carcinogenic COPCs, an incremental lifetime cancer risk (ILCR) is calculated by multiplying the estimated dose (in mg/(kg-d)) by the appropriate slope factor (in (mg/(kg-d))<sup>-1</sup>) for dermal and oral exposures, and the amortized air concentration (mg/m<sup>3</sup>) by the appropriate unit risk (in (mg/m<sup>3</sup>)<sup>-1</sup>) for

inhalation. This is shown in Equation (5-28). The estimate corresponds to an incremental risk of an individual developing cancer over a lifetime as a result of exposure. Risk is defined as follows:

$$Risk_o = (D_s \times TRV_o) + (D_{dermal}^s \times TRV_d) \quad (5-28)$$

$$Risk_i = (D_{a,p} + D_{a,v}) \times TRV_i$$

Where:

TRV<sub>o</sub> = Toxicity Reference Value for carcinogenic effects from oral exposure (SF)  
 [(mg/(kg-d))<sup>-1</sup>]

TRV<sub>d</sub> = Toxicity Reference Value for carcinogenic effects from dermal exposure  
 [(mg/(kg-d))<sup>-1</sup>] (assumed equal to TRV<sub>o</sub>)

TRV<sub>i</sub> = Toxicity Reference Value for carcinogenic effects from inhalation (UR)  
 [(mg/m<sup>3</sup>)<sup>-1</sup>]

The doses or intakes for the different pathways of exposure are presented in Section 4.2.5 and the TRVs used in this assessment are presented in Section 4.3. The calculated risk is then compared to acceptable benchmarks. In this assessment, an incremental risk level of 1 x 10<sup>-6</sup> (1 in 1,000,000) was used to assess carcinogenic effects, consistent with the MOE (2011) to represent an “essentially negligible” risk.

#### 5.4.2.1 Addition Across Exposure Routes

##### Combining Oral and Dermal Exposures:

In an RA, it is generally acceptable to sum hazard quotients or risk levels across exposure routes when the adverse health effect has the same toxicological endpoint and mechanism of action.

In this assessment, it was considered that the mechanisms of action for the oral and dermal exposure routes (when toxicity values are available) are the same for all contaminants, and therefore HQs and risks were summed across the oral and dermal exposure routes.

##### Combining Oral, Dermal, and Inhalation Exposures:

Inhalation was also added to the oral and dermal total only if the endpoint and mechanism of action were the same as those for oral and dermal exposure. The inhalation TRVs outlined in Table 5.20 were reviewed for common endpoints and mechanisms of action. The following COPCs were found to have common endpoints and therefore their inhalation components can be combined with their dermal and oral components:

Non-Carcinogenic Exposure:

- Pb;
- Se;
- U;
- PHC F2;
- Benzene;
- Carbon Tetrachloride;
- Chloroform;
- 1,1-Dichloroethylene;
- Trichloroethylene;
- Vinyl chloride; and
- PCBs.

Carcinogenic Exposure:

- As;
- Benzene;
- Trichloroethylene;
- Vinyl chloride; and
- PCBs.

### 5.4.3 Risk Estimation

The risk results (i.e., radiological SI values and non-radiological HQ and Risk values) are presented below, and discussed further in Section 5.4.4.

#### 5.4.3.1 Radiological Risk

Table 5.19 presents the estimated radiological risk results for the commercial workers, fishermen, residents and yacht club users, based on exposure locations and radionuclide concentrations in the respective environmental media. [REDACTED]

Tier 1 estimates are based on maximum concentrations in the relevant environmental media. Outdoor air concentrations were selected to correspond to the location of the receptor, as noted in Table 5.7; external gamma dose rates from the MicroShield modelling [REDACTED] were also added. Radionuclide concentrations are either from measured data or estimated using specific activity assumptions (see Section 5.2.3).

Table 5.19 HHRA – Radiological Risk Results – Public Receptors (Tier 1)

Case	Age Group	Total Dose, including Gamma (mSv/y)	Dose Limit (mSv/y, from CNSC 2000)	SI
Commercial Worker	Adult	4.82E-02	1	0.05
Fenceline Walker	Adult	1.28E-02	1	0.01
Fisherperson	Adult	2.92E-01	1	0.29
Resident	Adult	2.91E-01	1	0.29
Resident	Child	3.21E-01	1	0.32
Resident	Infant	3.14E-01	1	0.31
Yacht Club User	Adult	8.09E-02	1	0.081
Park User	Adult	6.60E-02	1	0.07
Park User	Child	6.64E-02	1	0.07
Park User	Infant	6.90E-02	1	0.07
Commercial Worker + Resident	Adult	3.39E-01	1	0.34
Fenceline Walker + Resident	Adult	3.04E-01	1	0.30
Park User + Resident	Infant*	3.83E-01	1	0.38
Yacht Club Member + Resident	Adult	3.72E-01	1	0.37
Fisherperson + Resident	Adult	5.83E-01	1	0.58

Note:

\* - Infant was conservatively selected as the compound receptor, because its estimated dose is highest.

As seen in Table 5.19, all estimated doses are below the dose limit; therefore a Tier 2 radiological HHRA is not required.

#### 5.4.3.2 Non-Radiological Hazard and Risk

The following tables present the estimated non-radiological hazard (non-carcinogenic) and risk (carcinogenic) results for worker and member of public receptors, based on their respective environmental media and exposure locations.

Tier 1 estimates are based on maximum measured concentrations in groundwater, surface water, and soil, along with estimated maximum air concentrations based on air modelling (see Section 3.1). For members of the public, outdoor air concentrations depend on the location of the receptor, as noted in Table 5.7. For Tier 1, the indoor air concentrations have been (very conservatively) set equal to outdoor air concentrations. For workers, maximum modelled groundwater vapour concentrations are used, as discussed in Section 5.2.3.3.



Tier 1 calculations were also carried out for the compound receptors, e.g., a member of the public who fishes near the Port Hope harbour and lives in Port Hope (see Section 5.1). The compounding of receptors did not introduce any new COPC exceedances; however, for the Park User + Resident receptor, aluminum exceedances expanded, from two age groups (i.e., exceedances in toddler and adults) to three age groups: the infant park user + resident HQ exceeded 0.2. Therefore, aluminum was carried into Tier 2 for all age groups.

Tier 2a estimates are based on 95% UCLM concentrations in groundwater, surface water, and soil.

Following Tier 2a, the remaining COPCs were reviewed and those that are not associated with releases from the PHCF were identified and excluded from further assessment. This includes:

- Antimony;
- Aluminum;
- Barium;
- Boron;
- Cadmium;
- Chlorine;
- Chromium;
- Copper;
- Iron;
- Potassium;
- Manganese;
- Nickel;
- Lead;
- Selenium;
- Sodium;
- Strontium;
- Zinc (*off-site zinc only*);
- Vanadium.

Tier 2b estimates – for the remaining PHCF-related COPCs – are based on maximum modelled incremental concentrations in surface water, and location-specific soil data from 0 – 0.5 m depth (see Sections 3.3 and 5.2.3.1).

Tier 2c estimates – for the remaining PHCF-related COPCs - are based on 95<sup>th</sup> percentile modelled incremental concentrations in surface water (see Section 3.3) and modelled incremental uranium concentrations in soil (see Section 3.2).

Final – Environmental Risk Assessment for the Cameco Port Hope Conversion Facility

**Tier 1:**

Table 5.20 HHRA – HQ & Risk – Resident Receptors (Surface Water, T1)

**a) Hazard HQs (Non-Carcinogenic)**

SW COPCs	RESIDENT				
	Infant	Toddler	Child	Teen	Adult
	<i>HQ<sub>o+d</sub></i>	<i>HQ<sub>o+d</sub></i>	<i>HQ<sub>o+d</sub></i>	<i>HQ<sub>o+d</sub></i>	<i>HQ<sub>o+d+i</sub></i>
Ammonia	NC	NC	NC	NC	NC
Aluminum	2.1E-04	2.7E-03	2.2E-03	1.4E-03	1.2E-03
Arsenic	1.4E-02	<b>1.2E+00</b>	<b>9.7E-01</b>	<b>6.2E-01</b>	<b>5.5E-01</b>
Fluoride	3.4E-03	1.8E-03	9.7E-04	5.8E-04	5.1E-04
Strontium	4.2E-03	3.1E-03	1.9E-03	1.2E-03	1.0E-03
Uranium	4.7E-03	9.0E-03	6.6E-03	4.1E-03	3.7E-03
Zinc	6.0E-06	3.5E-02	2.8E-02	1.6E-02	1.4E-02
Dichlorodifluoromethane	2.8E-05	9.8E-05	7.4E-05	4.7E-05	4.2E-05

Notes:

Bold – indicates where the HQ is greater than 0.2.

NC – Not Calculated: key parameters (e.g., data, TRV, or TF) are not available.

**b) Risk ILCRs (Carcinogenic)**

SW COPCs	RESIDENT				
	Infant	Toddler	Child	Teen	Adult
	<i>Risk<sub>o+d</sub></i>	<i>Risk<sub>o+d</sub></i>	<i>Risk<sub>o+d</sub></i>	<i>Risk<sub>o+d</sub></i>	<i>Risk<sub>o+d</sub></i>
Arsenic	4.8E-08	<b>3.7E-05</b>	<b>4.6E-05</b>	<b>3.3E-05</b>	<b>2.3E-04</b>

Notes:

Bold – indicates where the risk (ILCR) is greater than 1 x 10<sup>-6</sup>.

Final – Environmental Risk Assessment for the Cameco Port Hope Conversion Facility

Table 5.21 HHRA – HQ – Resident Receptors (Off-Site Soil, T1)

a) Hazard HQs (Non-Carcinogenic)

Offsite Soil COPCs	Resident (All Locations)									
	Infant		Toddler		Child		Teen		Adult	
	HQo+d	HQo+d+i	HQo+d	HQo+d+i	HQo+d	HQo+d+i	HQo+d	HQo+d+i	HQo+d	HQo+d+i
Ammonia	NC	NA	NC	NA	NC	NA	NC	NA	NC	NA
Antimony	<b>4.6E-01</b>	NA	<b>6.3E-01</b>	NA	<b>2.9E-01</b>	NA	<b>2.3E-01</b>	NA	<b>1.7E+00</b>	NA
Aluminum	1.7E-01	1.7E-01	<b>2.7E-01</b>	<b>2.7E-01</b>	1.3E-01	1.3E-01	1.0E-01	1.0E-01	<b>6.6E-01</b>	<b>6.6E-01</b>
Arsenic	<b>7.2E-01</b>	NA	<b>2.5E+01</b>	NA	<b>1.8E+01</b>	NA	<b>1.3E+01</b>	NA	<b>1.2E+01</b>	NA
Barium	4.8E-03	4.8E-03	1.6E-02	1.6E-02	9.9E-03	9.9E-03	7.5E-03	7.5E-03	2.2E-02	2.2E-02
Boron	2.1E-02	NA	<b>1.5E+01</b>	NA	<b>1.1E+01</b>	NA	<b>8.2E+00</b>	NA	<b>6.5E+00</b>	NA
Cadmium	2.9E-03	NA	<b>8.3E-01</b>	NA	<b>6.3E-01</b>	NA	<b>4.6E-01</b>	NA	<b>3.7E-01</b>	NA
Cobalt	7.2E-03	NA	7.1E-02	NA	4.6E-02	NA	3.4E-02	NA	3.3E-02	NA
Copper	3.7E-03	NA	<b>2.9E-01</b>	NA	1.8E-01	NA	1.2E-01	NA	8.9E-02	NA
Lead	<b>1.6E+00</b>	<b>1.6E+00</b>	<b>3.7E+01</b>	<b>3.7E+01</b>	<b>2.7E+01</b>	<b>2.7E+01</b>	<b>2.0E+01</b>	<b>2.0E+01</b>	<b>2.1E+01</b>	<b>2.1E+01</b>
Manganese	2.9E-02	NA	<b>8.9E-01</b>	NA	<b>7.3E-01</b>	NA	<b>4.7E-01</b>	NA	<b>4.2E-01</b>	NA
Molybdenum	1.1E-04	NA	9.9E-03	NA	8.2E-03	NA	5.2E-03	NA	3.8E-03	NA
Nickel	2.1E-02	NA	<b>7.7E-01</b>	NA	<b>5.7E-01</b>	NA	<b>4.2E-01</b>	NA	<b>4.0E-01</b>	NA
Nitrate & Nitrite	1.9E-03	NA	2.4E-03	NA	1.0E-03	NA	8.2E-04	NA	7.1E-03	NA
Selenium	5.2E-04	5.2E-04	3.7E-02	3.7E-02	2.7E-02	2.7E-02	2.0E-02	2.0E-02	1.8E-02	1.8E-02
Silver	1.2E-03	NA	1.6E-03	NA	6.8E-04	NA	5.4E-04	NA	4.5E-03	NA
Strontium	1.0E-02	NA	<b>6.4E-01</b>	NA	<b>4.8E-01</b>	NA	<b>3.6E-01</b>	NA	<b>3.1E-01</b>	NA
Uranium	1.1E-01	1.1E-01	<b>2.3E-01</b>	<b>2.3E-01</b>	1.2E-01	1.2E-01	9.5E-02	9.5E-02	<b>4.6E-01</b>	<b>4.6E-01</b>
Vanadium	1.9E-01	NA	<b>1.6E+00</b>	NA	<b>1.1E+00</b>	NA	<b>8.4E-01</b>	NA	<b>1.3E+00</b>	NA
Zinc	7.0E-03	NA	<b>6.8E-01</b>	NA	<b>5.1E-01</b>	NA	<b>3.4E-01</b>	NA	<b>2.7E-01</b>	NA

Notes:

Bold – indicates where HQ is greater than 0.2.

NC – Not Calculated: key parameters (e.g., data, TRV, or TF) not available.

NA – Not Applicable.

Final – Environmental Risk Assessment for the Cameco Port Hope Conversion Facility

**b) Risk ILCRs (Carcinogenic)**

OffSite Soil COPCs	Resident (All Locations)									
	Infant		Toddler		Child		Teen		Adult	
	Risko+d	Risko+d+i	Risko+d	Risko+d+i	Risko+d	Risko+d+i	Risko+d	Risko+d+i	Risko+d	Risko+d+i
Arsenic	2.4E-06	2.4E-06	7.5E-04	7.5E-04	8.5E-04	8.5E-04	7.2E-04	7.2E-04	4.9E-03	4.9E-03

Notes:

Bold – indicates where the risk (ILCR) is greater than  $1 \times 10^{-6}$ .

Final – Environmental Risk Assessment for the Cameco Port Hope Conversion Facility

Table 5.22 HHRA – HQ – Park User Receptors (Off-Site Soil, T1)

a) Hazard HQs (Non-Carcinogenic) – Park User

Soil COPCs	Park User									
	Infant		Toddler		Child		Teen		Adult	
	HQo+d	HQo+d+i	HQo+d	HQo+d+i	HQo+d	HQo+d+i	HQo+d	HQo+d+i	HQo+d	HQo+d+i
Ammonia	NC	NA	NC	NA	NC	NA	NC	NA	NC	NA
Antimony	1.4E-02	NA	1.9E-02	NA	8.5E-03	NA	6.7E-03	NA	5.1E-02	NA
Aluminum	1.2E-01	1.2E-01	1.9E-01	1.9E-01	9.2E-02	9.2E-02	7.1E-02	7.1E-02	<b>4.6E-01</b>	<b>4.6E-01</b>
Arsenic	1.3E-01	NA	<b>4.3E+00</b>	NA	<b>3.2E+00</b>	NA	<b>2.3E+00</b>	NA	<b>2.1E+00</b>	NA
Barium	4.5E-03	4.5E-03	1.5E-02	1.5E-02	9.2E-03	9.2E-03	6.9E-03	6.9E-03	2.0E-02	2.0E-02
Boron	4.1E-03	NA	<b>2.8E+00</b>	NA	<b>2.1E+00</b>	NA	<b>1.6E+00</b>	NA	<b>1.3E+00</b>	NA
Cadmium	1.4E-03	NA	<b>4.2E-01</b>	NA	<b>3.1E-01</b>	NA	<b>2.3E-01</b>	NA	1.8E-01	NA
Cobalt	1.8E-03	NA	1.8E-02	NA	1.2E-02	NA	8.7E-03	NA	8.3E-03	NA
Copper	1.1E-03	NA	8.9E-02	NA	5.5E-02	NA	3.5E-02	NA	2.7E-02	NA
Lead	<b>7.8E-01</b>	<b>7.8E-01</b>	<b>1.8E+01</b>	<b>1.8E+01</b>	<b>1.4E+01</b>	<b>1.4E+01</b>	<b>1.0E+01</b>	<b>1.0E+01</b>	<b>1.1E+01</b>	<b>1.1E+01</b>
Manganese	2.3E-02	NA	<b>7.0E-01</b>	NA	<b>5.8E-01</b>	NA	<b>3.7E-01</b>	NA	<b>3.3E-01</b>	NA
Molybdenum	1.5E-05	NA	1.3E-03	NA	1.1E-03	NA	7.0E-04	NA	5.1E-04	NA
Nickel	8.2E-03	NA	<b>3.1E-01</b>	NA	<b>2.3E-01</b>	NA	1.7E-01	NA	1.6E-01	NA
Nitrate & Nitrite	1.7E-03	NA	2.1E-03	NA	9.2E-04	NA	7.3E-04	NA	6.3E-03	NA
Selenium	4.2E-04	4.2E-04	2.9E-02	2.9E-02	2.1E-02	2.1E-02	1.6E-02	1.6E-02	1.4E-02	1.4E-02
Silver	2.7E-04	NA	3.5E-04	NA	1.5E-04	NA	1.2E-04	NA	1.0E-03	NA
Strontium	7.4E-03	NA	<b>4.7E-01</b>	NA	<b>3.5E-01</b>	NA	<b>2.6E-01</b>	NA	<b>2.3E-01</b>	NA
Uranium	4.0E-02	4.0E-02	7.9E-02	7.9E-02	4.3E-02	4.3E-02	3.3E-02	3.3E-02	1.6E-01	1.6E-01
Vanadium	1.2E-01	NA	<b>1.1E+00</b>	NA	<b>7.4E-01</b>	NA	<b>5.5E-01</b>	NA	<b>8.5E-01</b>	NA
Zinc	2.1E-03	NA	<b>2.0E-01</b>	NA	1.5E-01	NA	1.0E-01	NA	8.1E-02	NA

Notes:

Park soil concentrations estimated from Cameco sampling location 19, which is close to RPK1 (park near Dorset St. E warehouse).

Bold – indicates where HQ is greater than 0.2.

NC – Not Calculated: key parameters (e.g., data, TRV, or TF) not available.

NA – Not Applicable.

Final – Environmental Risk Assessment for the Cameco Port Hope Conversion Facility

**b) Hazard HQs (Non-Carcinogenic) – Park User + Resident**

Soil COPCs	Park User + Resident									
	Infant		Toddler		Child		Teen		Adult	
	HQo+d	HQo+d+i	HQo+d	HQo+d+i	HQo+d	HQo+d+i	HQo+d	HQo+d+i	HQo+d	HQo+d+i
Ammonia	NC	NA	NC	NA	NC	NA	NC	NA	NC	NA
Antimony	<b>4.8E-01</b>	NA	<b>6.5E-01</b>	NA	<b>3.0E-01</b>	NA	<b>2.3E-01</b>	NA	<b>1.8E+00</b>	NA
Aluminum	<b>3.0E-01</b>	<b>3.0E-01</b>	<b>4.5E-01</b>	<b>4.5E-01</b>	<b>2.2E-01</b>	<b>2.2E-01</b>	1.7E-01	1.7E-01	<b>1.1E+00</b>	<b>1.1E+00</b>
Arsenic	<b>8.4E-01</b>	NA	<b>2.9E+01</b>	NA	<b>2.1E+01</b>	NA	<b>1.6E+01</b>	NA	<b>1.4E+01</b>	NA
Barium	9.3E-03	9.3E-03	3.0E-02	3.0E-02	1.9E-02	1.9E-02	<b>1.4E-02</b>	1.4E-02	4.2E-02	4.2E-02
Boron	2.6E-02	NA	<b>1.8E+01</b>	NA	<b>1.3E+01</b>	NA	<b>9.8E+00</b>	NA	<b>7.8E+00</b>	NA
Cadmium	4.3E-03	NA	<b>1.2E+00</b>	NA	<b>9.4E-01</b>	NA	<b>6.9E-01</b>	NA	<b>5.5E-01</b>	NA
Cobalt	9.0E-03	NA	8.9E-02	NA	5.8E-02	NA	4.3E-02	NA	4.1E-02	NA
Copper	4.8E-03	NA	<b>3.8E-01</b>	NA	<b>2.4E-01</b>	NA	1.5E-01	NA	1.2E-01	NA
Lead	<b>2.3E+00</b>	<b>2.3E+00</b>	<b>5.5E+01</b>	<b>5.5E+01</b>	<b>4.1E+01</b>	<b>4.1E+01</b>	<b>3.0E+01</b>	<b>3.0E+01</b>	<b>3.2E+01</b>	<b>3.2E+01</b>
Manganese	5.1E-02	NA	<b>1.6E+00</b>	NA	<b>1.3E+00</b>	NA	<b>8.3E-01</b>	NA	<b>7.5E-01</b>	NA
Molybdenum	1.2E-04	NA	1.1E-02	NA	9.3E-03	NA	5.9E-03	NA	4.3E-03	NA
Nickel	2.9E-02	NA	<b>1.1E+00</b>	NA	<b>8.0E-01</b>	NA	<b>5.9E-01</b>	NA	<b>5.6E-01</b>	NA
Nitrate & Nitrite	3.6E-03	NA	4.5E-03	NA	2.0E-03	NA	1.6E-03	NA	1.3E-02	NA
Selenium	9.4E-04	9.4E-04	6.6E-02	6.6E-02	4.8E-02	4.8E-02	3.6E-02	3.6E-02	3.2E-02	3.2E-02
Silver	1.5E-03	NA	1.9E-03	NA	8.3E-04	NA	6.5E-04	NA	5.6E-03	NA
Strontium	1.7E-02	NA	<b>1.1E+00</b>	NA	<b>8.4E-01</b>	NA	<b>6.2E-01</b>	NA	<b>5.5E-01</b>	NA
Uranium	1.5E-01	1.5E-01	<b>3.0E-01</b>	<b>3.0E-01</b>	1.7E-01	1.7E-01	1.3E-01	1.3E-01	<b>6.2E-01</b>	<b>6.2E-01</b>
Vanadium	<b>3.1E-01</b>	NA	<b>2.7E+00</b>	NA	<b>1.9E+00</b>	NA	<b>1.4E+00</b>	NA	<b>2.2E+00</b>	NA
Zinc	9.1E-03	NA	<b>8.8E-01</b>	NA	<b>6.6E-01</b>	NA	<b>4.4E-01</b>	NA	<b>3.5E-01</b>	NA

Notes:

Park soil concentrations estimated from Cameco sampling location 19, which is close to RPK1 (park near Dorset St. E warehouse).

Bold – indicates where HQ is greater than 0.2.

NC – Not Calculated: key parameters (e.g., data, TRV, or TF) not available.

NA – Not Applicable.

Final – Environmental Risk Assessment for the Cameco Port Hope Conversion Facility

**c) Risk ILCRs (Carcinogenic) - Park User**

OffSite Soil COPCs	Park User									
	Infant		Toddler		Child		Teen		Adult	
	Risko+d	Risko+d+i	Risko+d	Risko+d+i	Risko+d	Risko+d+i	Risko+d	Risko+d+i	Risko+d	Risko+d+i
Arsenic	4.2E-07	4.2E-07	<b>1.3E-04</b>	<b>1.3E-04</b>	<b>1.5E-04</b>	<b>1.5E-04</b>	<b>1.3E-04</b>	<b>1.3E-04</b>	<b>8.6E-04</b>	<b>8.6E-04</b>

Notes:

Park soil concentrations estimated from Cameco sampling location 19, which is close to RPK1 (park near Dorset St. E warehouse).

Bold – indicates where the risk (ILCR) is greater than  $1 \times 10^{-6}$ .

**d) Risk ILCRs (Carcinogenic) - Park User + Resident**

OffSite Soil COPCs	Park User + Resident									
	Infant		Toddler		Child		Teen		Adult	
	Risko+d	Risko+d+i	Risko+d	Risko+d+i	Risko+d	Risko+d+i	Risko+d	Risko+d+i	Risko+d	Risko+d+i
Arsenic	<b>2.8E-06</b>	<b>2.8E-06</b>	<b>8.8E-04</b>	<b>8.8E-04</b>	<b>1.0E-03</b>	<b>1.0E-03</b>	<b>8.5E-04</b>	<b>8.5E-04</b>	<b>5.7E-03</b>	<b>5.7E-03</b>

Notes:

Park soil concentrations estimated from Cameco sampling location 19, which is close to RPK1 (park near Dorset St. E warehouse).

Bold – indicates where the risk (ILCR) is greater than  $1 \times 10^{-6}$ .

Final – Environmental Risk Assessment for the Cameco Port Hope Conversion Facility

Table 5.23 HHRA – HQ – Resident Receptors (Indoor & Outdoor Air, U only, T1)

**Hazard HQs (Non-Carcinogenic)**

Air COPCs	Resident (All Locations)				
	Infant	Toddler	Child	Teen	Adult
	HQi	HQi	HQi	HQi	HQi
Uranium	1.6E-01	1.6E-01	1.6E-01	1.6E-01	1.6E-01

Notes:

Table 5.24 HHRA – HQ – Park User Receptors (Outdoor Air, U only, T1)

**Hazard HQs (Non-Carcinogenic)**

Air COPCs	Park User					Park User + Resident				
	Infant	Toddler	Child	Teen	Adult	Infant	Toddler	Child	Teen	Adult
	HQi	HQi	HQi	HQi	HQi	HQi	HQi	HQi	HQi	HQi
Uranium	1.7E-04	1.7E-04	1.7E-04	1.7E-04	1.7E-04	1.6E-01	1.6E-01	1.6E-01	1.6E-01	1.6E-01

Notes:

Park air concentrations estimated from Location RPK1 (park near Dorset St. E warehouse).



Table 5.25 HHRA – HQ & Risk – Fisherperson Receptors (Surface Water, T1)

**a) Hazard HQs (Non-Carcinogenic)**

SW COPCs	Fisherperson		Fisherperson + Resident	
	Adult		Adult	
	<i>HQo+d</i>	<i>HQo+d+i</i>	<i>HQo+d</i>	<i>HQo+d+i</i>
Ammonia	NC	NA	NC	NA
Aluminum	2.1E-03	NA	3.3E-03	NA
Arsenic	<b>5.5E-01</b>	NA	<b>1.1E+00</b>	NA
Fluoride	4.5E-06	NA	5.1E-04	NA
Strontium	4.3E-04	NA	1.5E-03	NA
Uranium	3.0E-03	3.0E-03	6.7E-03	6.7E-03
Zinc	1.4E-02	NA	2.8E-02	NA
Dichlorodifluoromethane	3.9E-05	NA	8.1E-05	NA

Notes: Bold – indicates where HQ is greater than 0.2.

NC – Not Calculated: key parameters (e.g., data, TRV, or TF) not available.

NA – Not Applicable.

**b) Risk ILCRs (Carcinogenic)**

SW COPCs	Fisherperson (Adult)		Fisherperson + Resident (Adult)	
	<i>Risko+d</i>	<i>Risko+d+i</i>	<i>Risko+d</i>	<i>Risko+d+i</i>
	Arsenic	<b>2.3E-04</b>	<b>2.3E-04</b>	<b>4.6E-04</b>

Notes:

Bold – indicates where the risk (ILCR) is greater than  $1 \times 10^{-6}$ .

Table 5.26 HHRA – HQ – Fisherperson Receptors (Air; U only, T1)

Air COPCs	Fisherperson	Fisherperson + Resident
	Adult	Adult
	HQi	HQi
Uranium	2.4E-02	1.9E-01

Notes:

Risk (ILCR) dose estimates not applicable to uranium (not identified as a carcinogen).

Table 5.27 HHRA – HQ & Risk – Yacht/Boat Receptors (Surface Water, T1)

**a) Hazard HQs (Non-Carcinogenic)**

SW COPCs	Yacht/Boater		Yacht/Boater + Resident	
	Adult		Adult	
	HQo+d	HQo+d+i	HQo+d	HQo+d+i
Ammonia	NC	NA	NC	NA
Aluminum	7.9E-08	NA	1.2E-03	NA
Arsenic	5.6E-06	NA	<b>5.5E-01</b>	NA
Fluoride	1.5E-09	NA	5.1E-04	NA
Strontium	5.4E-07	NA	1.0E-03	NA
Uranium	1.1E-05	1.1E-05	3.7E-03	3.7E-03
Zinc	8.3E-09	NA	1.4E-02	NA
Dichlorodifluoromethane	9.7E-09	NA	4.2E-05	NA

Notes:

Bold – indicates where HQ is greater than 0.2.

NC – Not Calculated: key parameters (e.g., data, TRV, or TF) not available.

NA – Not Applicable.

**b) Risk ILCRs (Carcinogenic)**

SW COPCs	Yacht/Boater (Adult)		Yacht/Boater (Adult)	
	Risko+d	Risko+d+i	Risko+d	Risko+d+i
Arsenic	2.3E-09	2.3E-09	<b>2.3E-04</b>	<b>2.3E-04</b>

Notes:

Bold – indicates where the risk (ILCR) is greater than  $1 \times 10^{-6}$ .

Table 5.28 HHRA – HQ – Off-Site Yacht/Boat Receptors (Air; U only, T1)

Soil COPCs	Yacht Club/Boater Receptor	Yacht Club/Boater + Resident
	Adult	Adult
	HQi	HQi
Uranium	2.4E-02	1.9E-01

Notes:

Risk (ILCR) dose estimates not applicable to uranium (not identified as a carcinogen).

Table 5.29 HHRA – HQ – Off-Site Fenceline Walker Receptors (Air; U only, T1)

Soil COPCs	Fenceline Walker Receptor	Fenceline Walker + Resident
	Adult	Adult
	HQi	HQi
Uranium	6.8E-03	1.7E-01

Notes:

Risk (ILCR) dose estimates not applicable to uranium (not identified as a carcinogen).

Table 5.30 HHRA – HQ – Off-Site Commercial Worker Receptors (Indoor & Outdoor Air; U only, T1)

Soil COPCs	Commercial Receptor	Commercial Receptor + Resident
	Adult	Adult
	HQi	HQi
Uranium	3.7E-02	1.997E-01

Notes:

Risk (ILCR) dose estimates not applicable to uranium (not identified as a carcinogen).

Final – Environmental Risk Assessment for the Cameco Port Hope Conversion Facility

**Tier 2a:**

Table 5.31 HHRA – HQ & Risk – Resident Receptors (Surface Water, T2a)

**a) Hazard HQs (Non-Carcinogenic)**

SW COPCs	Resident									
	Infant		Toddler		Child		Teen		Adult	
	HQo+d	HQo+d+i	HQo+d	HQo+d+i	HQo+d	HQo+d+i	HQo+d	HQo+d+i	HQo+d	HQo+d+i
Arsenic	1.3E-02	NA	<b>7.0E-01</b>	NA	<b>5.6E-01</b>	NA	<b>3.6E-01</b>	NA	<b>3.2E-01</b>	NA

Notes:

Bold – indicates where the HQ is greater than 0.2.

NA – Not Applicable.

**b) Risk ILCRs (Carcinogenic)**

SW COPCs	Resident									
	Infant		Toddler		Child		Teen		Adult	
	Risko+d	Risko+d+i	Risko+d	Risko+d+i	Risko+d	Risko+d+i	Risko+d	Risko+d+i	Risko+d	Risko+d+i
Arsenic	4.4E-08	4.4E-08	<b>2.1E-05</b>	<b>2.1E-05</b>	<b>2.6E-05</b>	<b>2.6E-05</b>	<b>1.9E-05</b>	<b>1.9E-05</b>	<b>1.3E-04</b>	<b>1.3E-04</b>

Notes:

Bold – indicates where the risk (ILCR) is greater than  $1 \times 10^{-6}$ .

Final – Environmental Risk Assessment for the Cameco Port Hope Conversion Facility

Table 5.32 HHRA – HQ & Risk – Resident Receptors (Off-Site Soil, T2a)

a) Hazard HQs (Non-Carcinogenic)

Offsite Soil COPCs	Resident (All Locations)									
	Infant		Toddler		Child		Teen		Adult	
	HQo+d	HQo+d+i	HQo+d	HQo+d+i	HQo+d	HQo+d+i	HQo+d	HQo+d+i	HQo+d	HQo+d+i
Aluminum	1.1E-01	1.1E-01	1.7E-01	1.7E-01	8.4E-02	8.4E-02	6.5E-02	6.5E-02	4.2E-01	4.2E-01
Antimony	1.5E-01	NA	2.1E-01	NA	9.5E-02	NA	7.5E-02	NA	5.7E-01	NA
Arsenic	2.6E-01	NA	9.0E+00	NA	6.6E+00	NA	4.9E+00	NA	4.3E+00	NA
Boron	6.8E-03	NA	4.7E+00	NA	3.5E+00	NA	2.6E+00	NA	2.1E+00	NA
Cadmium	1.8E-03	NA	5.2E-01	NA	3.9E-01	NA	2.9E-01	NA	2.3E-01	NA
Copper	2.0E-03	NA	1.6E-01	NA	9.6E-02	NA	6.2E-02	NA	4.7E-02	NA
Lead	7.3E-01	7.3E-01	1.7E+01	1.7E+01	1.3E+01	1.3E+01	9.4E+00	9.4E+00	9.9E+00	9.9E+00
Manganese	2.1E-02	NA	6.5E-01	NA	5.4E-01	NA	3.4E-01	NA	3.1E-01	NA
Nickel	7.6E-03	NA	2.8E-01	NA	2.1E-01	NA	1.6E-01	NA	1.5E-01	NA
Strontium	7.7E-03	NA	4.9E-01	NA	3.7E-01	NA	2.7E-01	NA	2.4E-01	NA
Uranium	8.1E-02	8.1E-02	1.6E-01	1.6E-01	8.8E-02	8.8E-02	6.7E-02	6.7E-02	3.2E-01	3.2E-01
Vanadium	1.3E-01	NA	1.1E+00	NA	7.7E-01	NA	5.7E-01	NA	8.8E-01	NA
Zinc	2.9E-03	NA	2.8E-01	NA	2.1E-01	NA	1.4E-01	NA	1.1E-01	NA

Notes:

Bold – indicates where HQ is greater than 0.2.

NA – Not Applicable.

b) Risk ILCRs (Carcinogenic)

OffSite Soil COPCs	Resident (All Locations)									
	Infant		Toddler		Child		Teen		Adult	
	Risko+d	Risko+d+i	Risko+d	Risko+d+i	Risko+d	Risko+d+i	Risko+d	Risko+d+i	Risko+d	Risko+d+i
Arsenic	8.8E-07	8.8E-07	2.7E-04	2.7E-04	3.1E-04	3.1E-04	2.6E-04	2.6E-04	1.8E-03	1.8E-03

Notes: Bold – indicates where the risk (ILCR) is greater than  $1 \times 10^{-6}$ .

Final – Environmental Risk Assessment for the Cameco Port Hope Conversion Facility

Table 5.33 HHRA – HQ & Risk – Park User Receptors (Off-Site Soil, T2a)

**Hazard HQs (Non-Carcinogenic)**

Park Soil COPCs	Park User									
	Infant		Toddler		Child		Teen		Adult	
	HQo+d	HQo+d+i	HQo+d	HQo+d+i	HQo+d	HQo+d+i	HQo+d	HQo+d+i	HQo+d	HQo+d+i
Aluminum	1.2E-01	1.2E-01	1.8E-01	1.8E-01	9.1E-02	9.1E-02	7.0E-02	7.0E-02	4.6E-01	4.6E-01
Antimony	1.3E-02	NA	1.7E-02	NA	7.9E-03	NA	6.2E-03	NA	4.7E-02	NA
Arsenic	1.1E-01	NA	<b>3.8E+00</b>	NA	<b>2.8E+00</b>	NA	<b>2.0E+00</b>	NA	<b>1.8E+00</b>	NA
Boron	3.8E-03	NA	<b>2.6E+00</b>	NA	<b>2.0E+00</b>	NA	<b>1.5E+00</b>	NA	<b>1.2E+00</b>	NA
Cadmium	1.3E-03	NA	<b>3.8E-01</b>	NA	<b>2.9E-01</b>	NA	<b>2.1E-01</b>	NA	1.7E-01	NA
Chromium	1.7E-01	NA	<b>3.2E-01</b>	NA	1.7E-01	NA	1.3E-01	NA	<b>6.8E-01</b>	NA
Lead	<b>7.3E-01</b>	<b>7.3E-01</b>	<b>1.7E+01</b>	<b>1.7E+01</b>	<b>1.3E+01</b>	<b>1.3E+01</b>	<b>9.4E+00</b>	<b>9.4E+00</b>	<b>9.9E+00</b>	<b>9.9E+00</b>
Manganese	2.2E-02	NA	<b>6.8E-01</b>	NA	<b>5.7E-01</b>	NA	<b>3.6E-01</b>	NA	<b>3.2E-01</b>	NA
Nickel	7.3E-03	NA	<b>2.7E-01</b>	NA	<b>2.0E-01</b>	NA	1.5E-01	NA	1.4E-01	NA
Strontium	7.3E-03	NA	<b>4.7E-01</b>	NA	<b>3.5E-01</b>	NA	<b>2.6E-01</b>	NA	<b>2.3E-01</b>	NA
Vanadium	1.2E-01	NA	<b>1.0E+00</b>	NA	<b>7.4E-01</b>	NA	<b>5.5E-01</b>	NA	<b>8.5E-01</b>	NA
Zinc	1.9E-03	NA	1.8E-01	NA	1.4E-01	NA	9.1E-02	NA	7.4E-02	NA

Notes:

Park soil concentrations estimated from Cameco sampling location 19, which is close to RPK1 (park near Dorset St. E warehouse). There was not sufficient data available to calculate a 95% UCLM, so the 95<sup>th</sup> percentile was used.

Bold – indicates where HQ is greater than 0.2.

NA – Not Applicable.

**b) Risk ILCRs (Carcinogenic)**

OffSite Soil COPCs	Park User									
	Infant		Toddler		Child		Teen		Adult	
	Risko+d	Risko+d+i	Risko+d	Risko+d+i	Risko+d	Risko+d+i	Risko+d	Risko+d+i	Risko+d	Risko+d+i
Arsenic	3.7E-07	3.7E-07	<b>1.1E-04</b>	<b>1.1E-04</b>	<b>1.3E-04</b>	<b>1.3E-04</b>	<b>1.1E-04</b>	<b>1.1E-04</b>	<b>7.5E-04</b>	<b>7.5E-04</b>

Notes:

Park soil concentrations estimated from Cameco sampling location 19, which is close to RPK1 (park near Dorset St. E warehouse). There was not sufficient data available to calculate a 95% UCLM, so the 95<sup>th</sup> percentile was used.

Bold – indicates where the risk (ILCR) is greater than  $1 \times 10^{-6}$ .

Final – Environmental Risk Assessment for the Cameco Port Hope Conversion Facility

Table 5.34 HHRA – HQ & Risk – Fisherman Receptor (Surface Water, T2a)

**a) Hazard HQs (Non-Carcinogenic)**

SW COPCs	Fisherman (Adult)	
	HQo	HQo+d+i
Arsenic	<b>3.2E-01</b>	NA

Notes:

Bold – indicates where the HQ is greater than 0.2.

NA – Not Applicable.

**b) Risk ILCRs (Carcinogenic)**

SW COPCs	Fisherman (Adult)	
	Risko+d	Risko+d+i
Arsenic	<b>1.3E-04</b>	<b>1.3E-04</b>

Notes:

Bold – indicates where the risk (ILCR) is greater than  $1 \times 10^{-6}$ .

**Tier 2b:**

Table 5.35 HHRA – HQ & Risk – Resident Receptor (Surface Water, T2b)

**a) Hazard HQs (Non-Carcinogenic)**

SW COPCs	Resident (All Locations)									
	Infant		Toddler		Child		Teen		Adult	
	HQo+d	HQo+d+i	HQo+d	HQo+d+i	HQo+d	HQo+d+i	HQo+d	HQo+d+i	HQo+d	HQo+d+i
Arsenic	4.5E-04	NA	<b>3.1E-01</b>	NA	<b>2.5E-01</b>	NA	1.6E-01	NA	1.4E-01	NA

Notes:

Bold – indicates where the HQ is greater than 0.2.

NA – Not Applicable.

**b) Risk ILCRs (Carcinogenic)**

SW COPCs	Resident (All Locations)									
	Infant		Toddler		Child		Teen		Adult	
	Risko+d	Risko+d+i	Risko+d	Risko+d+i	Risko+d	Risko+d+i	Risko+d	Risko+d+i	Risko+d	Risko+d+i
Arsenic	1.5E-09	1.5E-09	<b>9.3E-06</b>	<b>9.3E-06</b>	<b>1.2E-05</b>	<b>1.2E-05</b>	<b>8.5E-06</b>	<b>8.5E-06</b>	<b>5.8E-05</b>	<b>5.8E-05</b>

Notes:

Bold – indicates where the risk (ILCR) is greater than  $1 \times 10^{-6}$ .

Final – Environmental Risk Assessment for the Cameco Port Hope Conversion Facility

Table 5.36 HHRA – HQ & Risk – Hayward St. Resident Receptor (Off-Site Soil, T2b)

**a) Hazard HQs (Non-Carcinogenic)**

Offsite Soil COPCs	Resident (Hayward St.)									
	Infant		Toddler		Child		Teen		Adult	
	HQo+d	HQo+d+i	HQo+d	HQo+d+i	HQo+d	HQo+d+i	HQo+d	HQo+d+i	HQo+d	HQo+d+i
Arsenic	<b>2.0E-01</b>	NA	<b>7.0E+00</b>	NA	<b>5.1E+00</b>	NA	<b>3.8E+00</b>	NA	<b>3.3E+00</b>	NA
Uranium	7.8E-02	7.8E-02	1.5E-01	1.5E-01	8.4E-02	8.4E-02	6.5E-02	6.4E-02	<b>3.1E-01</b>	<b>3.1E-01</b>

Notes:

Bold – indicates where HQ is greater than 0.2.

NA – Not Applicable.

**b) Risk ILCRs (Carcinogenic)**

OffSite Soil COPCs	Resident (Hayward St.)									
	Infant		Toddler		Child		Teen		Adult	
	Risko+d	Risko+d+i	Risko+d	Risko+d+i	Risko+d	Risko+d+i	Risko+d	Risko+d+i	Risko+d	Risko+d+i
Arsenic	6.8E-07	6.8E-07	<b>2.1E-04</b>	<b>2.1E-04</b>	<b>2.4E-04</b>	<b>2.4E-04</b>	<b>2.0E-04</b>	<b>2.0E-04</b>	<b>1.4E-03</b>	<b>1.4E-03</b>

Notes: Bold – indicates where the risk (ILCR) is greater than  $1 \times 10^{-6}$ .

Table 5.37 HHRA – HQ & Risk – Madison St. Resident Receptor (Off-Site Soil, T2b)

**a) Hazard HQs (Non-Carcinogenic)**

Offsite Soil COPCs	Resident (Madison St.)									
	Infant		Toddler		Child		Teen		Adult	
	HQo+d	HQo+d+i	HQo+d	HQo+d+i	HQo+d	HQo+d+i	HQo+d	HQo+d+i	HQo+d	HQo+d+i
Arsenic	<b>4.3E-01</b>	NA	<b>1.5E+01</b>	NA	<b>1.1E+01</b>	NA	<b>8.0E+00</b>	NA	<b>7.2E+00</b>	NA
Uranium	8.1E-02	8.1E-02	1.6E-01	1.6E-01	8.8E-02	8.8E-02	6.7E-02	6.7E-02	<b>3.2E-01</b>	<b>3.2E-01</b>

Notes:

Bold – indicates where HQ is greater than 0.2.

NA – Not Applicable.

**b) Risk ILCRs (Carcinogenic)**

OffSite Soil COPCs	Resident (Madison St.)									
	Infant		Toddler		Child		Teen		Adult	
	Risko+d	Risko+d+i	Risko+d	Risko+d+i	Risko+d	Risko+d+i	Risko+d	Risko+d+i	Risko+d	Risko+d+i
Arsenic	<b>1.5E-06</b>	<b>1.5E-06</b>	<b>4.5E-04</b>	<b>4.5E-04</b>	<b>5.1E-04</b>	<b>5.1E-04</b>	<b>4.3E-04</b>	<b>4.3E-04</b>	<b>2.9E-03</b>	<b>2.9E-03</b>

Notes: Bold – indicates where the risk (ILCR) is greater than  $1 \times 10^{-6}$ .



Final – Environmental Risk Assessment for the Cameco Port Hope Conversion Facility

Table 5.38 HHRA – HQ & Risk – Dorset St. Resident Receptor (Off-Site Soil, T2b)

a) Hazard HQs (Non-Carcinogenic)

Offsite Soil COPCs	Resident (DorsetSt.)									
	Infant		Toddler		Child		Teen		Adult	
	HQo+d	HQo+d+i	HQo+d	HQo+d+i	HQo+d	HQo+d+i	HQo+d	HQo+d+i	HQo+d	HQo+d+i
Arsenic	5.9E-02	NA	<b>2.1E+00</b>	NA	<b>1.5E+00</b>	NA	<b>1.1E+00</b>	NA	<b>9.9E-01</b>	NA
Uranium	1.9E-02	1.9E-02	3.8E-02	3.8E-02	2.1E-02	2.1E-02	1.6E-02	1.6E-02	7.8E-02	7.8E-02

Notes:

Bold – indicates where HQ is greater than 0.2.

NA – Not Applicable.

b) Risk ILCRs (Carcinogenic)

OffSite Soil COPCs	Resident (Dorset St.)									
	Infant		Toddler		Child		Teen		Adult	
	Risko+d	Risko+d+i	Risko+d	Risko+d+i	Risko+d	Risko+d+i	Risko+d	Risko+d+i	Risko+d	Risko+d+i
Arsenic	2.0E-07	2.0E-07	<b>6.2E-05</b>	<b>6.2E-05</b>	<b>7.1E-05</b>	<b>7.1E-05</b>	<b>6.0E-05</b>	<b>6.0E-05</b>	<b>4.1E-04</b>	<b>4.1E-04</b>

Notes: Bold – indicates where the risk (ILCR) is greater than  $1 \times 10^{-6}$ .

Final – Environmental Risk Assessment for the Cameco Port Hope Conversion Facility

Table 5.39 HHRA – HQ & Risk – Park User Receptor (Off-Site Soil, T2b)

**a) Hazard HQs (Non-Carcinogenic)**

Offsite Soil COPCs	Park User									
	Infant		Toddler		Child		Teen		Adult	
	HQo+d	HQo+d+i	HQo+d	HQo+d+i	HQo+d	HQo+d+i	HQo+d	HQo+d+i	HQo+d	HQo+d+i
Arsenic	5.9E-02	NA	<b>2.1E+00</b>	NA	<b>1.5E+00</b>	NA	<b>1.1E+00</b>	NA	<b>9.9E-01</b>	NA

Notes:

Park soil concentrations estimated from Cameco sampling location 19, which is close to RPK1 (park near Dorset St. E warehouse). Used only data from <0.5m.

Bold – indicates where HQ is greater than 0.2.

NA – Not Applicable.

**b) Risk ILCRs (Carcinogenic)**

OffSite Soil COPCs	Park User									
	Infant		Toddler		Child		Teen		Adult	
	Risko+d	Risko+d+i	Risko+d	Risko+d+i	Risko+d	Risko+d+i	Risko+d	Risko+d+i	Risko+d	Risko+d+i
Arsenic	2.0E-07	2.0E-07	<b>6.2E-05</b>	<b>6.2E-05</b>	<b>7.1E-05</b>	<b>7.1E-05</b>	<b>6.0E-05</b>	<b>6.0E-05</b>	<b>4.1E-04</b>	<b>4.1E-04</b>

Notes:

Park soil concentrations estimated from Cameco sampling location 19, which is close to RPK1 (park near Dorset St. E warehouse). Used only data from <0.5m.

Bold – indicates where the risk (ILCR) is greater than  $1 \times 10^{-6}$ .

Table 5.40 HHRA – HQ & Risk – Fisherperson Receptors (Surface Water, T2b)

**a) Hazard HQs (Non-Carcinogenic)**

SW COPCs	Fisherperson (Adult)	
	<i>HQo</i>	<i>HQo+d+i</i>
Arsenic	1.4E-01	NA

Notes:

Bold – indicates where the HQ is greater than 0.2.

NA – Not Applicable.

**b) Risk ILCRs (Carcinogenic)**

SW COPCs	Fisherperson (Adult)	
	<i>Risko+d</i>	<i>Risko+d+i</i>
Arsenic	5.8E-05	5.8E-05

Notes:

Bold – indicates where the risk (ILCR) is greater than  $1 \times 10^{-6}$ .

**Tier 2c:**

Table 5.41 HHRA – HQ & Risk – Resident Receptor (Surface Water, T2c)

**a) Hazard HQs (Non-Carcinogenic)**

SW COPCs	Resident (All Locations)									
	Infant		Toddler		Child		Teen		Adult	
	HQo+d	HQo+d+i	HQo+d	HQo+d+i	HQo+d	HQo+d+i	HQo+d	HQo+d+i	HQo+d	HQo+d+i
Arsenic	2.1E-04	NA	<b>2.4E-01</b>	NA	1.9E-01	NA	1.2E-01	NA	1.1E-01	NA

Notes:

Bold – indicates where the HQ is greater than 0.2.

NC – Not Calculated: key parameters (e.g., data, TRV, or TF) are not available.

NE – Not Evaluated: exposure pathway is not applicable to the particular receptor and has not been evaluated.

NA – Not Applicable.

**b) Risk ILCRs (Carcinogenic)**

SW COPCs	Resident (All Locations)									
	Infant		Toddler		Child		Teen		Adult	
	Risko+d	Risko+d+i	Risko+d	Risko+d+i	Risko+d	Risko+d+i	Risko+d	Risko+d+i	Risko+d	Risko+d+i
Arsenic	6.9E-10	6.9E-10	<b>7.1E-06</b>	<b>7.1E-06</b>	<b>9.0E-06</b>	<b>9.0E-06</b>	<b>6.5E-06</b>	<b>6.5E-06</b>	<b>4.5E-05</b>	<b>4.5E-05</b>

Notes:

Bold – indicates where the risk (ILCR) is greater than  $1 \times 10^{-6}$ .

NC – Not Calculated: key parameters (e.g., data, TRV, or TF) are not available.

NE – Not Evaluated: exposure pathway is not applicable to the particular receptor and has not been evaluated.

NA – Not Applicable.

Final – Environmental Risk Assessment for the Cameco Port Hope Conversion Facility

Table 5.42 HHRA – HQ – Hayward St. Resident Receptor (Off-Site Soil, T2c; U only)

**Hazard HQs (Non-Carcinogenic)**

Offsite Soil COPCs	Resident (Hayward St.)									
	Infant		Toddler		Child		Teen		Adult	
	<i>HQo+d</i>	<i>HQo+d+i</i>	<i>HQo+d</i>	<i>HQo+d+i</i>	<i>HQo+d</i>	<i>HQo+d+i</i>	<i>HQo+d</i>	<i>HQo+d+i</i>	<i>HQo+d</i>	<i>HQo+d+i</i>
Uranium	9.1E-04	9.1E-04	1.8E-03	1.8E-03	9.9E-04	9.9E-04	7.6E-04	7.6E-04	3.7E-03	3.7E-03

Notes:

Bold – indicates where HQ is greater than 0.2.

Table 5.43 HHRA – HQ – Madison St. Resident Receptor (Off-Site Soil, T2c; U only)

**Hazard HQs (Non-Carcinogenic)**

Offsite Soil COPCs	Resident (Madison St.)									
	Infant		Toddler		Child		Teen		Adult	
	<i>HQo+d</i>	<i>HQo+d+i</i>	<i>HQo+d</i>	<i>HQo+d+i</i>	<i>HQo+d</i>	<i>HQo+d+i</i>	<i>HQo+d</i>	<i>HQo+d+i</i>	<i>HQo+d</i>	<i>HQo+d+i</i>
Uranium	6.9E-04	6.9E-04	1.4E-03	1.4E-03	7.4E-04	7.4E-04	5.7E-04	5.7E-04	2.7E-03	2.7E-03

Notes:

Bold – indicates where HQ is greater than 0.2.

Table 5.44 HHRA – HQ – Park User Receptor (Off-Site Soil, T2c; U only)

**Hazard HQs (Non-Carcinogenic)**

Offsite Soil COPCs	Resident (Madison St.)									
	Infant		Toddler		Child		Teen		Adult	
	<i>HQo+d</i>	<i>HQo+d+i</i>	<i>HQo+d</i>	<i>HQo+d+i</i>	<i>HQo+d</i>	<i>HQo+d+i</i>	<i>HQo+d</i>	<i>HQo+d+i</i>	<i>HQo+d</i>	<i>HQo+d+i</i>
Uranium	1.1E-04	NA	2.3E-04	NA	1.2E-04	NA	9.5E-05	NA	4.6E-04	NA

Notes:

Bold – indicates where HQ is greater than 0.2.

NA – Not Applicable.

Table 5.45 HHRA – HQ & Risk – Fisherman Receptors (Surface Water, T2c)

**a) Hazard HQs (Non-Carcinogenic)**

SW COPCs	Fisherman (Adult)	
	HQo	HQo+d+i
Arsenic	1.1E-01	NA

Notes:

Bold – indicates where the HQ is greater than 0.2.

NA – Not Applicable.

**b) Risk ILCRs (Carcinogenic)**

SW COPCs	Fisherman (Adult)	
	Risko+d	Risko+d+i
Arsenic	4.5E-05	4.5E-05

Notes:

Bold – indicates where the risk (ILCR) is greater than  $1 \times 10^{-6}$ .

## 5.4.4 Discussion

### 5.4.4.1 Radiological

Tier 1 calculations, based on maximum radionuclide levels in environmental media were completed. As shown in Table 5.19, all estimated Tier 1 doses are below the dose limit. Therefore, undue risk to members of the public from radionuclide levels in environmental media is unlikely.

### 5.4.4.2 Non-Radiological

As shown in the risk calculation tables in Section 5.4.2, there were no HQ or Risk exceedances in Tier 1 for COPCs in any environmental media for:

- yacht club users;
- fenceline walkers; or
- commercial workers

The resident and fisherman receptors had no Tier 1 exceedances for inhalation; however, these receptors did have Tier 1 exceedances for soil and surface water pathways. The park user receptors also had Tier 1 exceedances for soil pathways. Therefore, resident and fisherman exposure to soil and surface water COPCs, as well as park user exposure to soil COPCs, underwent further investigation in subsequent Tiers. This is discussed below.

(i) **Resident and Park User Receptors – Off-Site Soil COPCs**

The resident and park user receptors are the only public receptors who are exposed to COPCs in soil. Tier 1 calculations were performed using the maximum measured concentrations of COPCs in off-site soil, regardless of location. Tier 1 calculations identified several receptor-COPC combinations that produced HQ or risk estimates in excess of their corresponding benchmark values. These exceedances are summarized in Table 5.46.

Table 5.46 HHRA – Offsite Soil – Summary of Tier 1 HQ & Risk Exceedances

**a) Resident Receptor**

Offsite Soil COPCs	Resident Receptor (All Locations)									
	Infant		Toddler		Child		Teen		Adult	
	HQ	Risk	HQ	Risk	HQ	Risk	HQ	Risk	HQ	Risk
Aluminum			X						X	
Antimony	X		X		X		X		X	
Arsenic	X	X	X	X	X	X	X	X	X	X
Boron			X		X		X		X	
Cadmium			X		X		X		X	
Copper			X							
Lead	X		X		X		X		X	
Manganese			X		X		X		X	
Nickel			X		X		X		X	
Strontium			X		X		X		X	
Uranium			X						X	
Vanadium			X		X		X		X	
Zinc			X		X		X		X	

**b) Park User Receptor**

Offsite Soil COPCs	Park User Receptor (RPK1, near Dorset St. E Warehouse)									
	Infant		Toddler		Child		Teen		Adult	
	HQ	Risk	HQ	Risk	HQ	Risk	HQ	Risk	HQ	Risk
Aluminum									X	
Antimony									X	
Arsenic		X	X	X	X	X	X	X	X	X
Boron			X		X		X		X	
Cadmium			X		X		X		X	
Copper										
Lead	X		X		X		X		X	
Manganese			X		X		X		X	
Nickel			X		X				X	
Strontium			X		X		X		X	
Uranium										
Vanadium			X		X		X		X	
Zinc			X						X	

**c) Park User + Resident Receptor**

Offsite Soil COPCs	Park User + Resident Receptor										
	Infant		Toddler		Child		Teen		Adult		
	HQ	Risk	HQ	Risk	HQ	Risk	HQ	Risk	HQ	Risk	
Aluminum			X		X					X	
Antimony	X		X		X		X		X		
Arsenic	X	X	X	X	X	X	X	X	X	X	
Boron			X		X		X		X		
Cadmium			X		X		X		X		
Copper			X								
Lead	X		X		X		X		X		
Manganese			X		X		X		X		
Nickel			X		X		X		X		
Strontium			X		X		X		X		
Uranium			X						X		
Vanadium			X		X		X		X		
Zinc			X		X		X		X		

As seen in the above tables, the compound receptor (Park User + Resident) has identical exceedance results to the resident receptor, except for one additional exceedance: aluminum for the child receptor. Therefore, the child age group was included in the Tier 2 aluminum calculations, which were being done for other age groups.

All receptor-COPC combinations with Tier 1 HQ or risk exceedances were carried forward for Tier 2a assessment.

Tier 2a calculations were performed for all receptor-COPC combinations that showed HQ or risk exceedances in Tier 1. Tier 2a calculations are based on the 95% UCLM of measured soil COPC concentrations in off-site residential soil, regardless of location. Tier 2a calculations also identified several receptor-COPC combinations that produced HQ or risk estimates in excess of their corresponding benchmark values. These exceedances are summarized in Table 5.47.



Table 5.47 HHRA – Offsite Soil – Summary of Tier 2a HQ & Risk Exceedances

**a) Resident Receptor**

Offsite Soil COPCs	Resident Receptor (All Locations)										
	Infant		Toddler		Child		Teen		Adult		
	HQ	Risk	HQ	Risk	HQ	Risk	HQ	Risk	HQ	Risk	
Aluminum										X	
Antimony			X				X			X	
Arsenic	X		X	X	X	X	X	X	X	X	X
Boron			X		X		X			X	
Cadmium			X		X		X			X	
Copper											
Lead	X		X		X		X			X	
Manganese			X		X		X			X	
Nickel			X		X						
Strontium			X		X		X			X	
Uranium										X	
Vanadium			X		X		X			X	
Zinc			X		X						

**b) Park User Receptor**

Offsite Soil COPCs	Park User Receptor (RPK1, near Dorset St. E Warehouse)										
	Infant		Toddler		Child		Teen		Adult		
	HQ	Risk	HQ	Risk	HQ	Risk	HQ	Risk	HQ	Risk	
Aluminum										X	
Antimony										X	
Arsenic		X	X	X	X	X	X	X	X	X	X
Boron			X		X		X			X	
Cadmium			X		X		X			X	
Chromium			X								
Lead	X		X		X		X			X	
Manganese			X		X		X			X	
Nickel			X		X					X	
Strontium			X		X		X			X	
Uranium											
Vanadium			X		X		X			X	
Zinc			X							X	

Final – Environmental Risk Assessment for the Cameco Port Hope Conversion Facility

All receptor-COPC combinations with Tier 2a HQ or risk exceedances were carried forward for Tier 2b assessment.

Before beginning Tier 2b calculations, the list of offsite soil COPCs with associated HQ or risk exceedances was reviewed and COPCs that are not associated with PHCF operations were identified and removed from further assessment. This is an important consideration since - as described in Section 2 - the Port Hope area contains a considerable amount of historical contamination that is not attributed to current PHCF operations. Offsite soil COPCs that are not related to PHCF operations are not the focus of this assessment. Overall, the following offsite soil COPCs were excluded from further assessment:

- |             |                |  |
|-------------|----------------|--|
| 1 Aluminum; | 7. Copper;     | 13. Vanadium; and,                     |
| 2 Antimony; | 8. Manganese;  | 14. Zinc ( <i>off-site</i> zinc only). |
| 3 Barium;   | 9. Nickel;     |  |
| 4 Boron;    | 10. Lead;      |  |
| 5 Cadmium;  | 11. Selenium;  |  |
| 6 Chromium; | 12. Strontium; |  |

The remaining offsite soil COPCs that are associated with Cameco’s PHCF operations include:

- Arsenic; and,
- Uranium.

Arsenic and uranium proceeded to undergo Tier 2b assessment based on location-specific concentrations in offsite soil corresponding to the Hayward St., Madison St., and Dorset St. resident receptor locations. Furthermore, offsite soil data from the 0 – 0.5 m depth range was used, as this represents the range of soil depths that human receptors are likely to be exposed to (MOE 1996). Tier 2b calculations also identified select receptor-COPC combinations that produced HQ or risk estimates in excess of their corresponding benchmark values. These exceedances are summarized in Table 5.48.

Table 5.48 HHRA – Offsite Soil – Summary of Tier 2b HQ & Risk Exceedances

Offsite Soil COPCs	Resident Receptors (Location-Specific)									
	Infant		Toddler		Child		Teen		Adult	
	HQ	Risk	HQ	Risk	HQ	Risk	HQ	Risk	HQ	Risk
<b>Hayward St. Resident Receptor</b>										
Arsenic	X		X	X	X	X	X	X	X	X
Uranium									X	
<b>Madison St. Resident Receptor</b>										
Arsenic	X	X	X	X	X	X	X	X	X	X
Uranium									X	
<b>Dorset St. Resident Receptor</b>										
Arsenic			X	X	X	X	X	X	X	X

The summary results in Table 5.48 indicate that arsenic and uranium are the remaining COPCs with select receptor-COPC combinations that have HQ or risk exceedances. Arsenic and uranium in offsite are now discussed individually, below.

*Uranium in Offsite Soil*

The Hayward St. and Madison St. resident receptors have residual HQ exceedances for uranium and are therefore carried forward into a Tier 2c assessment.

For Tier 2c assessment, the Port Hope soil uranium buildup model was used to predict incremental location-specific soil uranium concentrations as described in Section 3.2. The resulting incremental soil uranium concentrations are used as the Tier 2c exposure concentrations. As shown in Tables 5.42, 5.43 and 5.44, these Tier 2c incremental concentrations produce HQ results that are less than the corresponding benchmark, and therefore, no undue effects are expected from uranium in offsite soil that is related to current PHCF operations.

*Arsenic in Offsite Soil*

The Hayward St., Madison St., and Dorset St. resident receptors show several residual HQ and risk exceedances based on age group. However, it is important that these results are understood in context.

As described in Section 2, the Port Hope area contains historical contamination that is not attributed to Cameco's PHCF operations. The main pathway linking offsite soil arsenic concentrations and PHCF operations is from facility air emissions. However, Table 4.5 presents a screening of PHCF airborne emissions from 2014 which includes a comparison of maximum POI arsenic air concentrations to the corresponding regulatory screening criterion. From Table 4.5 it is clear that the concentration of arsenic in air (contributed by PHCF emissions) is small, at only 17% of the corresponding MOE POI criterion. Given the low air concentrations associated with facility emissions, it is unlikely that offsite soil arsenic concentrations are a direct result of current PHCF operations.

In addition, following the previous 2009 SWRA (SENES 2009a,b), a detailed arsenic exposure study was completed and is documented in SENES (2010). SENES (2010) conducted soil arsenic modelling which showed that over a 25 year period (assuming that emissions continue at the same rate) there is expected to be essentially no change to the arsenic level in the area. SENES (2010) concluded that atmospheric releases of arsenic from the PHCF are not having any discernable impact on the soil quality in the Port Hope area and no further action is therefore required. Furthermore, the SENES (2010) study examined the exposure potentially experienced by Port Hope residents and determined that this level of exposure is within the "normal" or "background" exposure experienced by Canadians. From this, SENES (2010) concluded that undue health risks are not expected. Lastly, SENES (2010) notes that biological monitoring of Canadian locations where people have been exposed to elevated arsenic has not supported potential health impacts.

(i) **Resident and Fisherman Receptors – Arsenic in Surface Water**

The resident, fisherman, and yacht club user receptors experience one or more pathways which result in exposure to COPCs in surface water. The Tier 1 calculations, based on maximum COPC concentrations in environmental media, identified only arsenic as having HQ and risk results that exceed their corresponding HQ or risk criteria for the resident and fisherman receptors. The compound receptor, i.e., fisherman + resident, did not introduce any new exceedances.

Given these Tier 1 results, Tier 2a calculations were undertaken (using 95% UCLM concentrations), followed by Tier 2b calculations (using maximum modelled incremental concentrations) and Tier 2c calculations (using 95% UCLM modelled incremental concentrations), all of which identify arsenic in surface water as having HQ and risk results that exceed their corresponding HQ or risk criteria for one or more receptor age groups. This includes the fisherman + resident compound receptor, and the boater + resident compound receptor (both adults). Therefore, arsenic warrants further discussion.

An examination of the dose estimates shows that the ingestion pathway is the primary contributor to overall arsenic dose. For resident receptors, the surface water ingestion dose pathway consists of: incidental ingestion of surface water while engaging in swimming activities and ingestion of fish caught from the harbour. For the fisherman receptor, the surface water ingestion dose pathway is based entirely on fish ingestion. For the resident receptor, of these ingestion components, ingestion of fish is by far the largest contributor, producing over 99% of the total arsenic ingestion dose in the case of the adult resident receptor. Subsequently, fish ingestion is the largest contributor to dose for the compound receptors (fisherman+resident and boater+resident),

Following the previous 2009 SWRA (SENES 2009a,b), a detailed arsenic risk study was completed and documented in SENES (2010). SENES (2010) included discussions on typical background levels of arsenic in fish, and identified an average arsenic concentration of 1.614 µg/g in fish samples from across Canada, including marine fish, freshwater fish, canned fish, and shellfish. In the present report, concentrations of arsenic in fish are estimated based on the concentration of arsenic in the surrounding harbour surface water using transfer factors obtained from literature (see Section 6.2.7). Using the maximum and 95% UCLM measured concentration of arsenic in harbour surface water, as well as the modelled incremental maximum and 95% UCLM concentrations, the estimated concentrations of arsenic in fish caught and consumed from the harbour are as follows:

- Based on max. measured surface water arsenic: 1.28 µg/g FW;
- Based on 95UCLM measured surface water arsenic: 0.74 µg/g FW;
- Based on modelled maximum incremental surface water arsenic: 0.33 µg/g FW; and,
- Based on modelled 95UCLM incremental surface water arsenic: 0.25 µg/g FW.

By comparison, it is clear that even the maximum estimated concentration of arsenic in fish caught and consumed from the harbour is less than the typical background levels of arsenic found in fish. This is illustrated in Figure 5.4 below.

Figure 5.4. HHRA – Comparison of Fish Arsenic Levels ( $\mu\text{g/g FW}$ )

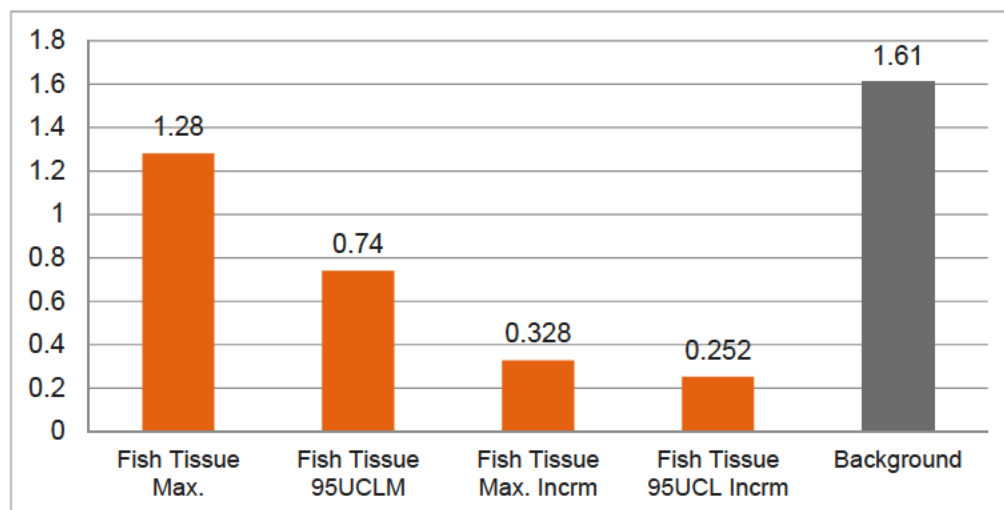

As discussed in SENES (2010), the levels of arsenic may be due to the general prevalence of arsenic, and not unique to the PHCF or to Port Hope. Arsenic is ubiquitous in nature. It is ranked as the twentieth most abundant element in the earth's crust. Thus, exposure to arsenic in daily life occurs from background concentrations that are present in the air, water and food wherever a person lives. Typical concentrations of arsenic in drinking water supplies in Canada range from  $<1 \mu\text{g/L}$  to  $5 \mu\text{g/L}$ . Arsenic is also present at low concentrations in most foods. Terrestrial animals and plants do not tend to accumulate arsenic (SENES 2010).

In addition, SENES (2010) mentions that arsenic may enter the body by ingestion, inhalation, or by absorption through the skin; and a number of factors influence how much arsenic is taken up in the body such as its speciation and solubility in body fluids. Environment Canada (1993) carried out an assessment of exposure of Canadians to background levels of arsenic in air, water, soil and food. That study indicated that the major pathways of exposure to background levels of arsenic were ingestion of water and food. Air and soil pathways were insignificant contributors to overall exposure, representing approximately 0.1% and 1% of the typical exposure, respectively. Based on an arsenic concentration of  $5 \mu\text{g/L}$  in drinking water supplies and background levels in food, Environment Canada estimated that a typical daily intake for an adult ranges from  $1.0 \times 10^{-4} \text{ mg}/(\text{kg d})$  to  $7 \times 10^{-4} \text{ mg}/(\text{kg d})$  and that the typical daily intake for a child (5 to 11 yrs) is from  $2.0 \times 10^{-4} \text{ mg}/(\text{kg d})$  to  $2.1 \times 10^{-3} \text{ mg}/(\text{kg d})$  (Environment Canada 1993), (SENES 2010).

Figure 5.5 and Figure 5.6 below compare the typical arsenic intake values for children and adults (discussed above) to the HHRA arsenic intakes estimated in this report for the resident receptor (the resident has the highest intake of arsenic from surface water among all human receptors). From these two comparisons it is observed that for both the child and adult age groups, even the highest estimated arsenic intake (based on maximum measured arsenic concentrations) is within the range of typical background.

These results are consistent with the overall findings of the SENES (2010) study. SENES (2010) discusses such findings, mentioning that since the exposure for Port Hope residents is within the exposure experience by Canadians and excessive health risks are not expected. The most likely parameter that results in the calculation of elevated health risks (both for typical exposure and Port Hope residents) is the toxicity reference values. Biological monitoring of locations where people have been exposed to elevated arsenic has not supported potential health impacts.

Figure 5.5. HHRA – Estimated Child Total Arsenic Intakes vs Background (mg/kg-d)

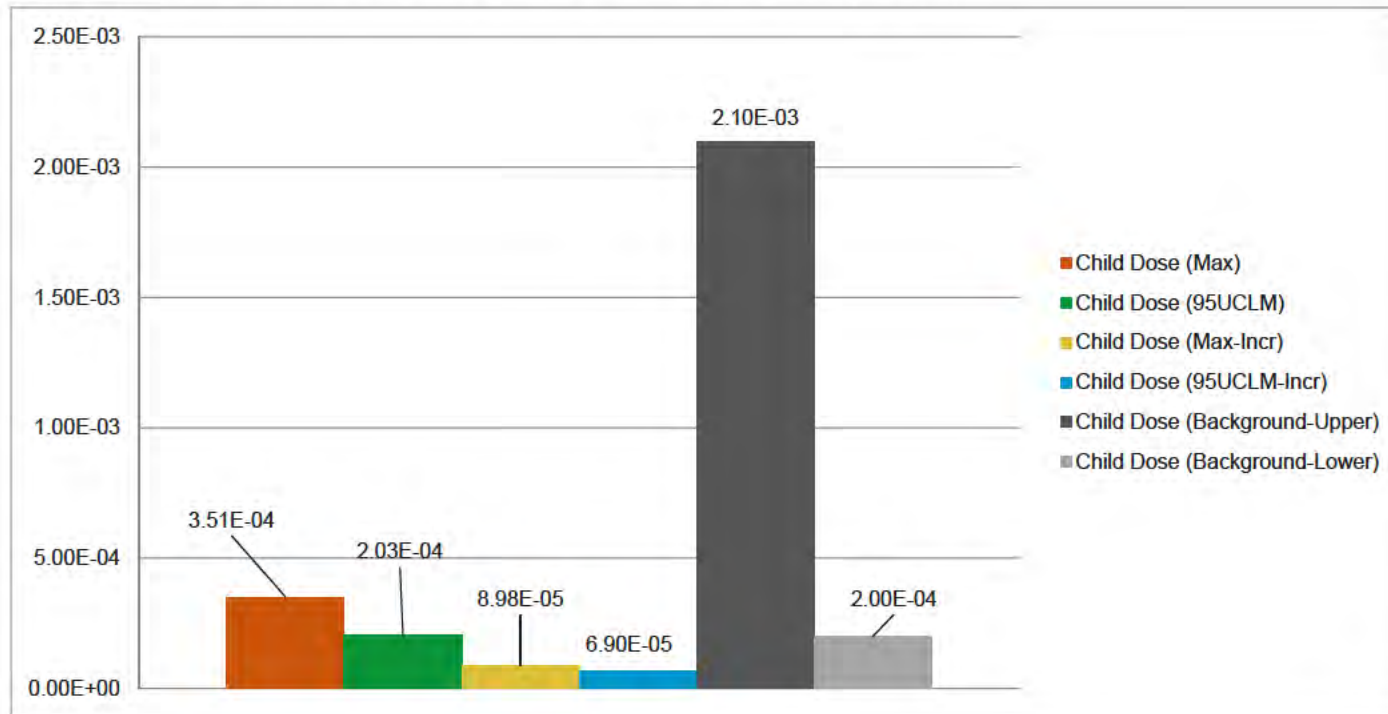
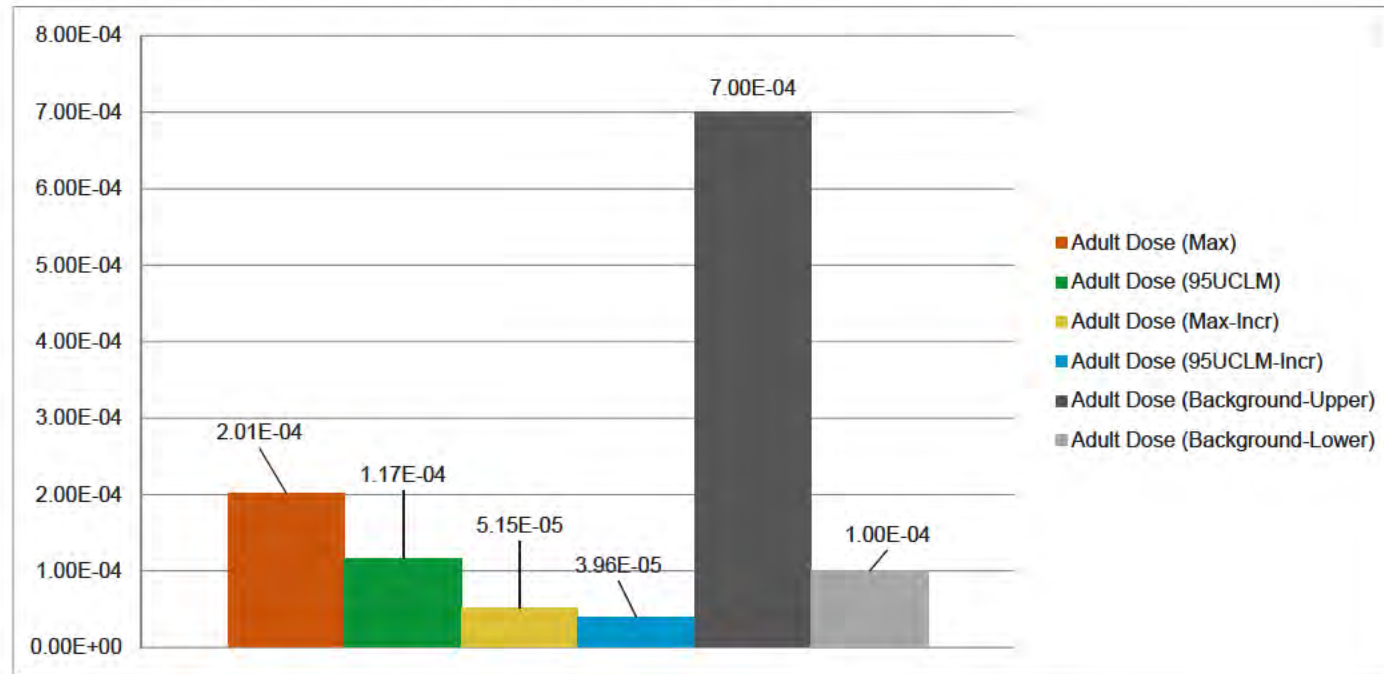

Figure 5.6. HHRA – Estimated Adult Total Arsenic Intakes vs Background (mg/kg-d)





## 5.5 Uncertainties in the HHRA

- **Problem Formulation and Human Health Conceptual Site Model:** The objective and scope of the ERA are set out clearly in Section 1.2: assessment of potential effects from current emissions associated with facility operations. Outside of this ERA scope, there is uncertainty associated with sources of contamination (site vs. off-site fill materials), historical vs. current contamination, etc. However, there is not uncertainty in the ERA scope: The HHRA focuses on receptors and pathways relevant to current operations, and where possible, evaluates risk associated with current operations (i.e., the ‘incremental’ cases). The CSM developed for the HHRA is clear on what pathways were included in the assessment. *Degree of uncertainty: Low.*
- **Receptor Selection and Characterization:** Receptor exposure characteristics were selected to be consistent with previous studies and the facility’s Derived Release Limit study. Exposure characteristics were selected either from Health Canada and CSA guidance, or from discussions with Cameco. Some unique exposure pathways were added to ensure a conservative estimate of risk, e.g., an individual who may fall into the harbour and swim to shore. Residential receptors were assumed to spend more time outdoors (3.5 h/d) than specified in Health Canada (1.5 h/d); this is conservative because it increases time spent inhaling outdoor air and contacting soil through activities such as gardening. For additional conservatism, the HHRA assessed hypothetical “compound receptors”, to represent receptors who may undertake more than one of the modelled activities. These compound receptors are expected to bound any potential human receptor exposure. *Degree of uncertainty: Low.*
- **Secondary COPC screening:** MOE component values specific to HHRA were used in the secondary soil and groundwater screening. As discussed earlier, the screening methodology was set up to minimize uncertainty: maximum measured concentrations were used, and in the absence of screening criteria (or other appropriate comparison values), contaminants were ‘screened-in’, i.e., retained as COPCs. This conservative approach resulted in a long list of COPCs. *Degree of uncertainty: Low.*
- **Exposure Point Concentrations:** Measured concentrations of COPCs, and measured activities of radionuclides, were used wherever such data was available. For non-radiological COPCs, the HHRA uses the maximum and 95% UCLM concentrations from throughout the year. The use of these concentrations assumes that receptors are exposed to these higher concentrations year-round, when in reality, there are both spatial and temporal variations in concentrations. Thus, exposures are likely overestimated in the assessment. *Degree of uncertainty: Low.*
- **Exposure Assessment:** The models and equations used to estimate risk to human receptors were based on guidance from CSA N288.1 and Health Canada. The use of these vetted methodologies is expected to reduce the potential error and/or uncertainty in the calculations. With respect to the parameters used to carry out the calculations (e.g., transfer factors and dose coefficients), the hierarchy of reference sources provided in the guidance documents was followed. If values were not found in the guidance documents (e.g., Pb and Po in CSA), conservative values from other literature sources were used. *Degree of uncertainty: Low.*
- **In order to minimize human calculation error,** internally-reviewed relational database models were used to calculate exposure, dose and risk in the HHRA. *Degree of uncertainty: Low.*
- **Toxicity Assessment:** As discussed in CSA N288.6, there is inherent uncertainty in the use of TRVs, e.g., due to the extrapolation of testing on lab species such as rats to humans, and due to the extrapolation from a controlled laboratory setting to real-world

conditions; To mitigate this uncertainty, the TRVs used were selected primarily from Health Canada PQRA guidance, which is recommended in N288.6. In general, the hierarchy of sources presented in N288.6 was followed in the selection of TRVs. These sources have already applied uncertainty factors to their TRVs. Therefore, while the inherent uncertainty in the TRVs cannot be removed, it has been controlled to the extent possible. Additional TRV conservatisms: (1) in the absence of dermal TRVs (which occurs for most COPCs), rather than neglect the pathway, the oral TRV was applied. (2) No adjustments were made for bioavailability. *Degree of uncertainty: Medium.*

- Risk Estimation: In this risk assessment, it was considered that the mechanisms of action for the oral and dermal exposure routes are the same for each specific contaminant. Therefore, HQs were summed across the oral and dermal exposure routes. This is a conservative approach to dealing with oral/dermal mechanisms of action, and it is therefore unlikely that risk would be underestimated by using this approach. Furthermore, for uranium, the oral, dermal, and inhalation doses have been combined since there is evidence of a common mechanism of action. *Degree of uncertainty: Low*
- This ERA did not include an assessment of multi-stressor effects, including interactions between contaminants, or between physical and chemical stressors. When dealing with multiple contaminants, there is a potential for interaction with other contaminants that may be encountered at the site. In addition, other factors including smoking and lifestyle factors are known to compound health effects. Synergism, potentiation, antagonism or additivity of toxic effects may occur. Some of these interactions can be handled in a simple fashion. For chemical mixtures that show additive effects based on toxicity assessment, the HQ or risk values may be added together. The lifetime risk can be expressed individually for each chemical (and by site of action, if necessary) and then totaled as a group. In practical terms, at levels of exposure typically considered in the assessment, the dose-response relation is assumed to be linear and, thus, additivity of effects (strictly by organ) is reasonable. This was done across pathways with similar endpoints (e.g., for uranium), but not across chemical mixtures. Overall, a detailed quantitative assessment of these interactions is outside the scope of this study. *Degree of uncertainty: Medium.*

Table 5.49 outlines some of the uncertainties identified in the HHRA and how in general, they have been overcome by using conservative assumptions that are likely to lead to an over-estimate of exposures (and therefore no change in the conclusions).

Table 5.49 HHRA – Summary of Uncertainties

Uncertainty	Likely Leads to Overestimate	Possibly Leads to Underestimate	Neither Overestimate or Underestimate
Use of transfer factors to estimate tissue concentrations	X		
Use of maximum or 95 <sup>th</sup> percentile concentrations to characterize exposures	X		
Use of conservative methods to estimate concentrations where direct measurements are not available	X		
Estimation of radionuclide concentrations not directly measured			X
Use of protective TRVs and maximum dose-response relationships	X		
Assuming 100% relative absorption for dermal uptake, and same mechanism of action as oral intake (i.e. combining exposures)	X		
Synergism, potentiation, antagonism, additivity of toxic effects (across multiple COPCs)		X	

## 6 ECOLOGICAL RISK ASSESSMENT

### 6.1 Problem Formulation

#### 6.1.1 Receptor Selection and Characterization

##### 6.1.1.1 Ecological Receptor Selection

It is important to note that, as discussed in Sections 2.1 and 2.2, the majority of the on-site area and considerable portions of the surrounding off-site area are developed, exhibiting significant development with very little natural habitat, vegetation, and animal life. The PHCF on-site area is almost entirely industrial, with only small pockets of landscaping (grass).

Overall, the study area includes portions of both terrestrial and aquatic environments, and therefore the following major biota groups warrant consideration:

- Freshwater aquatic environment:
  - Aquatic birds;
  - Aquatic mammals;
  - Amphibians;
  - Fish (benthic and pelagic);
  - Benthic invertebrates; and
  - Aquatic vegetation.
- Terrestrial environment:
  - Terrestrial birds;
  - Terrestrial mammals;
  - Terrestrial invertebrates; and
  - Terrestrial vegetation.

For each of the major biota groups mentioned above, a representative ecological receptor (also referred to as a Valued Ecological Component, VEC) was selected. The selection process is based on knowledge of the Site and considers several factors including: previous Port Hope environmental studies (i.e., SENES 2009a, 2009b) assessments and their related stakeholder input; field observations; accessibility of the environmental media (especially the limited accessibility of soil and groundwater); the potential species present in the area; and the size, quality, and distribution of natural areas (which are limited to small patches or narrow strips adjacent to the industrial facility).

Since completion of the SENES (2009a; 2009b) studies, PHCF staff have noted no additional biota requiring evaluation in the risk assessment.

Table 6.1 presents the details of ecological receptor identification.

Table 6.1 VEC/Ecological Receptor Selection

Major Biota Group	Related Environmental Media	Potential Representative Receptor	Comments
<b>Aquatic Environment</b>			
Aquatic Birds	<ul style="list-style-type: none"> <li>Air</li> <li>SW</li> <li>Sediment</li> </ul>	<ul style="list-style-type: none"> <li>Lesser Scaup</li> <li>Horned Grebe</li> </ul>	Identified in previous studies as being a VEC of interest. Scaup and grebe are also of ecological significance since lesser scaup is representative of select rare species, and horned grebe is itself a rare species and represents others (see species-at-risk discussion in Section 6.1.1.2 below).
Fish (benthic)	<ul style="list-style-type: none"> <li>SW</li> <li>Sediment</li> </ul>	<ul style="list-style-type: none"> <li>Benthic fish (generic)*</li> </ul>	Identified in previous studies as being a VEC of interest.
Fish (pelagic)	<ul style="list-style-type: none"> <li>SW</li> <li>Sediment</li> </ul>	<ul style="list-style-type: none"> <li>Pelagic fish (generic)*</li> </ul>	Identified in previous studies as being a VEC of interest.
Benthic Invertebrates	<ul style="list-style-type: none"> <li>SW</li> <li>Sediment</li> </ul>	<ul style="list-style-type: none"> <li>Benthic Invertebrates (generic)</li> </ul>	Identified in previous studies as being a VEC of interest.
Aquatic Vegetation	<ul style="list-style-type: none"> <li>SW</li> <li>Sediment</li> </ul>	<ul style="list-style-type: none"> <li>Macrophytes (generic)</li> </ul>	Identified in previous studies as being a VEC of interest.
<b>Terrestrial Environment</b>			
Terrestrial Birds	<ul style="list-style-type: none"> <li>Soil</li> <li>Air</li> <li>SW</li> </ul>	<ul style="list-style-type: none"> <li>Yellow Warbler</li> <li>American Robin</li> <li>Great Horned Owl</li> <li>Double-Crested Cormorant</li> <li>Barn Swallow</li> </ul>	Identified in previous studies as being a VEC of interest.  Yellow warbler, American robin, and great horned owl are selected as indicator species for the EcoRA because they represent different trophic levels and dietary intakes.
Terrestrial Mammals	<ul style="list-style-type: none"> <li>Soil</li> <li>Air</li> <li>SW</li> </ul>	<ul style="list-style-type: none"> <li>Red Fox</li> <li>Cotton-Tail Rabbit</li> <li>Meadow Vole</li> <li>Deer Mouse</li> </ul>	Identified in previous studies as being a VEC of interest. Deer mouse is represented by meadow vole, and as such, it is not necessary to consider it separately. Red fox represents a large mammal, and a higher terrestrial trophic level. Meadow vole represents a small mammal, and a lower trophic level.
Terrestrial Invertebrates	<ul style="list-style-type: none"> <li>Soil</li> <li>GW</li> </ul>	<ul style="list-style-type: none"> <li>Earthworm</li> </ul>	Identified in previous studies as being a VEC of interest.
Terrestrial Vegetation	<ul style="list-style-type: none"> <li>Soil</li> <li>Air</li> </ul>	<ul style="list-style-type: none"> <li>Terrestrial vegetation (generic)</li> </ul>	Identified in previous studies as being a VEC of interest.

Notes:

\* Benthic and pelagic fish are assessed as general biota groups for radiological and non-radiological (chemical) ecological risk assessment. Specific populations are assessed in thermal, entrainment and impingement studies (see Section 1.0).

Overall, based on Table 6.1, the following 14 representative ecological receptors have been selected:

1. Lesser Scaup;
2. Horned Grebe;
3. Benthic fish (generic group);
4. Pelagic fish (generic group);
5. Benthic invertebrates (generic group);
6. Aquatic vegetation (generic group);
7. Earthworm;
8. Terrestrial vegetation (generic group);
9. Yellow warbler;
10. American Robin;
11. Great horned owl;
12. Red fox;
13. Cotton-tail rabbit;
14. Meadow vole.

Overall, the selected indicator species are appropriate; since they reflect a variety of diets/feeding habits, cover a variety of trophic levels, are representative of the biota expected to be found in the study area, and are of interest to the facility.

#### 6.1.1.2 Species at Risk

The SENES (2009) SWRA involved an assessment of species at risk, and the implications for the ecological risk assessment. The findings of the SENES 2009 SWRA and other recent work near the PHCF regarding species at risk are reproduced here, because select indicator species have been chosen to represent rare species, consistent with CSA N288.6 (2012).

The Port Hope Harbour is distinctly man-made. In general, the site has undergone significant development and exhibits little natural habitat, vegetation and animal life. The Harbour includes a marina with a turning basin, a large centre pier area, and three jetties at the Harbour entrance. The shorelines (beaches) at the waterfront, east and west of the Harbour are the most natural features of the area. The PHCF is located north and adjacent to the west shoreline.

The west shoreline has a sandy beach, which contains pebble areas and coarse sand (LLRWMO 2005). There is sparse vegetation in this area, but the species are typical of beaches on the coasts of the southern Great Lakes. The composition of the beach area has been affected by the construction of jetties at the Harbour entrance.

Species on the beach include Eastern Cottonwood (*Populus deltoides*), Manitoba Maple and Sand Bar Willow (*Salix exigua*), with an understorey of Balsam Poplar and Red Osier Dogwood. The herbaceous layer contains Poison Ivy, Silverweed (*Potentilla anserine*), Canada Wild Rye (*Elymus canadensis*), Sea

Rocket (*Cakile edulenta*), Tall Wormwood (*Artemisia campestris*) and Pennyroyal (*Hedeoma pugeloides*), a rarely seen species in the Regional Study Area, but ranked as Provincially common (S4; AMEC 2005). In addition, no federally or provincially rare habitats are located within the area.

Based on data from the Willow Beach Field Naturalists (WBFN), an extensive list has been developed for the immediate area. From this list, a total of 42 bird species have a rare status, including endangered (END); regulated under *Endangered Species Act* (END-R); threatened (THR); vulnerable (VUL); and special concern (SC). Those from only the survey are listed below:

- Chimney Swift (*Chaetura pelagica*) – Threatened – SARA (*Species at Risk Act*) list;
- Horned Grebe (*Podiceps auritus*) – Critically imperiled – NHIC (Natural Heritage Information Centre);
- White-winged Scoter (*Melanitta fusca*), Long-tailed Duck (*Clangula hyemalis*), and Great Black-backed Gull (*Larus marinus*) – Imperiled – NHIC; and
- Semipalmated Sandpiper (*Calidris pusilla*), Black-crowned Night Heron (*Nycticorax nycticorax*), and Caspian Tern (*Hydroprogne caspia*) – Vulnerable – NHIC.

The horned grebe is one of the selected ecological receptors. As demonstrated in Table 6.2, the remaining of the above species can be represented by the selected ecological receptors (selected in Table 6.1).

Table 6.2 Representation of Rare Species using Indicator Receptors

Species with Rarity Status	Representative Indicator Species and Rationale
Chimney Swift ( <i>Chaetura pelagica</i> ) – Threatened – SARA	<b>Lesser Scaup (<i>Aythya affinis</i>)</b> Both predominantly eat aquatic invertebrates. Scaup diet may include clams, snails, crustaceans, aquatic insects, seeds, and aquatic plants. Chimney swift eat flying insects.
White-winged Scoter ( <i>Melanitta fusca</i> ) – Imperiled – NHIC	<b>Lesser Scaup (<i>Aythya affinis</i>)</b> Both predominantly eat aquatic invertebrates. Scaup diet may include clams, snails, crustaceans, aquatic insects, seeds, and aquatic plants. White-winged Scoters eat mollusks (especially clams and mussels), crustaceans, and insects; they occasionally consume aquatic plants and fish.
Long-tailed Duck ( <i>Clangula hyemalis</i> ) – Imperiled – NHIC	<b>Lesser Scaup (<i>Aythya affinis</i>)</b> Both predominantly eat aquatic invertebrates. Scaup diet may include clams, snails, crustaceans, aquatic insects, seeds, and aquatic plants. Long-tailed Ducks mostly eat aquatic invertebrates, including insects and crustaceans. They may also consume some bivalves, fish, fish eggs, and plant matter.
Semipalmated Sandpiper ( <i>Calidris pusilla</i> ) – Vulnerable – NHIC	<b>Lesser Scaup (<i>Aythya affinis</i>)</b> Both predominantly eat aquatic invertebrates. Scaup diet may include clams, snails, crustaceans, aquatic insects, seeds, and aquatic plants. Semipalmated Sandpipers mainly eat benthic invertebrates (small arthropods, molluscs, and annelids) in fresh or salt water and some terrestrial invertebrates (insects and spiders). There is insufficient suitable habitat for the sandpiper to expect significant exposure within the Harbour.
Great Black-backed Gull ( <i>Larus marinus</i> ) – Imperiled – NHIC	<b>Horned Grebe (<i>Podiceps auritus</i>)</b> Horned Grebe diet includes aquatic insects, fish, crustaceans and other small aquatic animals. Great Black-backed Gull diet includes fish, marine invertebrates, mammals, insects, birds, eggs, carrion and refuse.
Caspian Tern ( <i>Hydroprogne caspia</i> ) – Vulnerable – NHIC	<b>Horned Grebe (<i>Podiceps auritus</i>)</b> Horned Grebe diet includes aquatic insects, fish, crustaceans and other small aquatic animals. Caspian Tern diet consists of almost entirely fish; it occasionally includes crayfish and insects.
Black-crowned Night Heron ( <i>Nycticorax nycticorax</i> ) – Vulnerable – NHIC	<b>Horned Grebe (<i>Podiceps auritus</i>)</b> Horned Grebe diet includes aquatic insects, fish, crustaceans and other small aquatic animals. Black-crowned Night Heron diet includes aquatic invertebrates, fish, amphibians, lizards, snakes, rodents, eggs and other foods.

Notes:

SARA – *Species at Risk Act*.

NHIC – Natural Heritage Information Centre, Ontario Ministry of Natural Resources. Retrieved from:

[http://nhic.mnr.gov.on.ca/nhic\\_cfm](http://nhic.mnr.gov.on.ca/nhic_cfm)

Reference: Cornell Laboratory of Ornithology 2003. Bird Guide. Retrieved from:

<http://www.birds.cornell.edu/AllAboutBirds/BirdGuide/>



A search of the Natural Heritage Information Centre (NHIC 2009) database identified only one endangered or threatened species in the general area. As shown in Figure 6.1, the Eastern few-fruited sedge (*Carex oligocarpa*), which is ranked as S3 (vulnerable). The typical habitat for this species is moist uplands woods, which is not found at the PHCF property. It was not observed in a recent detailed survey of the surrounding environment of the Cameco PHCF (SENES 2011b). In this EcoRA study, it is represented by the terrestrial vegetation receptor.

Final – Environmental Risk Assessment for the Cameco Port Hope Conversion Facility

Figure 6.1. Potential Species at Risk in the Study Area NHIC (2009) Database Search Results



### 6.1.1.3 Receptor Characterization

Based on the environmental pathways and modes of exposure known for each receptor group, ecological profiles were developed for each receptor. These profiles, presented later in this Section, compile receptor-specific information related to:

- Trophic level or ecosystem role (e.g., predators or prey species);
- Size and body weight;
- Dietary composition;
- Food intake rate;
- Habitat;
- Habitat/home range spatial distribution and size; and
- Time spent in area.

## 6.1.2 Assessment and Measurement Endpoints

### Assessment endpoints

Indicator species are assessed using quantitative expressions referred to as “assessment endpoints”. These are expressions of the actual environmental values to be protected. In general, the assessment endpoints selected in this study are healthy populations of the identified indicator species within the study area.

### Measurement endpoints

Often assessment endpoints are qualitative in nature and do not lend themselves to direct measurement or quantification. Therefore, measurement endpoints are outlined, which are measurable or predictable expressions of the assessment endpoint.

The values of measurement endpoints will be dependent not only upon the species being protected, but also upon the level of protection provided. For example, a measurement endpoint suitable for ensuring reproductive success of a population may not be adequate to ensure the protection of each member of the population. This is particularly important for species at risk, as discussed below.

In this study, measurement endpoints are the screening index (SI): the ratio of an estimated exposure level (or an environmental concentration) divided by a corresponding TRV. As a result, when the chosen TRV encompasses long term effects based on survival (mortality), growth, or reproduction, then the measurement endpoint is closely linked to the assessment endpoint (healthy populations) and the necessary inferences can be made (i.e., can infer the ‘healthiness’ of the population). So, where an estimated exposure level is less than the corresponding TRV (i.e., screening index less than 1), effects on a population of biota are not expected; however, where an estimated exposure level is greater than the corresponding criterion (i.e., screening index greater than 1), deleterious effects on the population of biota may or may not occur and further study may be required to determine potential effects.

For species at risk, however, assessing effects at the population level may not be sufficiently stringent, since effects on even a few individuals are not considered to be acceptable. As a result, in cases where species at risk are represented by the study's indicator receptors, a more stringent (conservative) TRV is chosen to support the measurement endpoint (see Section 6.3.1). In this way the measurement endpoint, and the TRV upon which it is based, have a sufficient level of conservatism such that inference can be made regarding the assessment endpoint.

### **6.1.3 Ecological COPCs and Stressors – Secondary Screening**

As discussed in Section 3, COPCs were identified by comparing the maximum measured soil and groundwater concentrations to MOE SCS. These SCS are protective of both ecological and human receptors; in order to identify COPCs related specifically to ecological receptors, the maximum measured concentrations were compared to the appropriate ecological component values from MOE (2011). In the absence of a component value, COPCs were retained for the EcoRA.

#### **6.1.3.1 COPCs for Groundwater – Ecological Health**

Table 6.3 compares the maximum measured groundwater concentrations to the GW3 components from MOE (2011), which represent concentrations in groundwater that are protective of aquatic biota in surface water bodies potentially impacted by infiltrating groundwater. These values are also assumed to be protective of plants, soil organisms, mammals and birds. Table 9 GW3 values were selected because they are applicable to sites that are within 30 m of a water body. Where GW3 values were not available, Environment Canada's groundwater criteria for protection of freshwater life (EC 2014, Table 3) were consulted.

Table 6.3 Groundwater: Ecological Health Secondary Screening of COPCs

Parameter	Units	Maximum Measured Concentration	Table 9 GW3 (MOE 2011)	Interim GWQG (EC 2014)	Retained as GW COPC?
Fluoride	mg/L	75	nc	0.12	Yes
TDS	mg/L	158000	nc	nc	Yes (a)
Chloride	µg/L	8.20E+07	nc	1.20E+02	Yes
Nitrate	as N mg/L	115	nc	13	Yes
Ammonia (Total)*	as N mg/L	150	nc	1.27	Yes
Sulphate	mg/L	1200	nc	100	Yes
<b>Metals</b>					
Ag	µg/L	3.00E+01	1.2	-	Yes
Al	µg/L	2.20E+02	nc	1.00E+02	Yes
As	µg/L	1.15E+03	1500	-	No
Ca	µg/L	1.22E+07	nc	nc	Yes (a)
Cu	µg/L	290	69	-	Yes
Fe	µg/L	36700	nc	300	Yes
K	µg/L	1.08E+06	nc	nc	Yes (a)
Mg	µg/L	5.19E+06	nc	nc	Yes (a)
Mn	µg/L	2600	nc	nc	Yes (a)
Na	µg/L	2.37E+07	1.80E+06	-	Yes
Se	µg/L	538	50	-	Yes
Sr	µg/L	1.09E+06	nc	nc	Yes (a)
U	µg/L	21000	330	-	Yes
Zn	µg/L	2200	890	-	Yes
<b>Radionuclides</b>					
Ra-226	mBq/L	890	nc	nc	Yes (b)
<b>PHC</b>					
F1 (C6-C10)	µg/L	587	422.4	-	Yes
F2 (C10-C16)	µg/L	4440	165.7	-	Yes
F3 (C16-C34)	µg/L	1720	nc	nc	Yes (a)
F4 (C34-C50)	µg/L	1120	nc	nc	Yes (a)
<b>VOC</b>					
Benzene	µg/L	277	4600	-	No
Carbon Tetrachloride	µg/L	1.2	2000	-	No
Chloroform	µg/L	17	12400	-	No

Final – Environmental Risk Assessment for the Cameco Port Hope Conversion Facility

Parameter	Units	Maximum Measured Concentration	Table 9 GW3 (MOE 2011)	Interim GWQG (EC 2014)	Retained as GW COPC?
1,1-Dichloroethylene (vinylidene chloride)	µg/L	20.8	12000	-	No
cis-1,2-Dichloroethene	µg/L	1020	140000	-	No
trans-1,2-Dichloroethene	µg/L	28.6	220000	-	No
Ethylenedibromide	µg/L	<1	96000	-	No
Trichloroethylene	µg/L	1800	219000	-	No
Vinyl Chloride	µg/L	613	356000	-	No

Notes:

MOE (2011): *Rationale for Development of Soil and Groundwater Standards for Use at Contaminated Sites in Ontario*.

Appendix A3. GW Table 9 (non potable GW, 30 m from waterbody).

EC (2014): *Federal Interim Groundwater Quality Guidelines*. Appendix A. Table 3 (Industrial) - Tier 2, Water Use/ Exposure Pathway, Freshwater Life.

(-) - EC (2014) guideline not used (even if it exists) if MOE (2011) GW3 value available.

\* Ammonia guideline value estimated based on average pH of 8 and temperature of 5°C.

nc - no criterion available.

(a) - no component value; COPC carried forward in the assessment.

(b) - all radionuclides carried forward in the assessment.

As seen in the table above, the following COPCs were carried forward in the evaluation of groundwater for the EcoRA, either because the maximum measured concentration exceeded the levels protective of aquatic resources, or because component values were not available.

Fluoride
TDS
Chloride
Nitrate
Ammonia (Total)
Sulphate
Silver
Aluminum
Calcium
Copper
Iron
Potassium
Magnesium
Manganese
Sodium
Selenium
Strontium
Uranium
Zinc
Radium-226
Petroleum Hydrocarbon fraction F1 (C6-C10)
Petroleum Hydrocarbon fraction F2 (C10-C16)
Petroleum Hydrocarbon fraction F3 (C16-C34)
Petroleum Hydrocarbon fraction F4 (C34-C50)

### 6.1.3.2 COPCs for Soil - Ecological Health

Table 6.4 compares the maximum measured concentrations in soil to the appropriate generic components from MOE (2011). For soil, the components for plants and soil invertebrates and for mammals and birds are from MOE (2011) Table 2 (Full Depth, Non-potable Water, Coarse Textured Soil).

Final – Environmental Risk Assessment for the Cameco Port Hope Conversion Facility

Table 6.4 Soil: Ecological Health Secondary Screening of COPCs

Parameter	Units	Max Soil Conc	MOE SCS Values		Retained as COPC for EcoRA?	
			Plants and Soil Invertebrates	Mammals and Birds	Plants and Soil Invertebrates	Mammals and Birds
Fluoride	µg/g	20400	nc	nc	Yes (a)	Yes (a)
Ammonia (Total)	µg/g	2190	nc	nc	Yes (a)	Yes (a)
Nitrite	µg/g	11	nc	nc	Yes (a)	Yes (a)
Nitrate	µg/g	1500	nc	nc	Yes (a)	Yes (a)
Bromide	µg/g	490	nc	nc	Yes (a)	Yes (a)
Chloride	µg/g	696	nc	nc	Yes (a)	Yes (a)
Phosphate	µg/g	862	nc	nc	Yes (a)	Yes (a)
Sulphate	µg/g	15100	nc	nc	Yes (a)	Yes (a)
<b>Metals</b>						
Al	µg/g	36300	nc	nc	Yes (a)	Yes (a)
As	µg/g	1790	333	40	Yes	Yes
Ba	µg/g	2020	672	1500	Yes	Yes
B (Total)	µg/g	1790	nc	nc	Yes (a)	Yes (a)
Cd	µg/g	9.8	nc	nc	Yes (a)	Yes (a)
Co	µg/g	2730	nc	nc	Yes (a)	Yes (a)
Cu	µg/g	8830	3060	225	Yes	Yes
Fe	µg/g	180000	nc	nc	Yes (a)	Yes (a)
K	µg/g	45000	nc	nc	Yes (a)	Yes (a)
Mg	µg/g	84300	nc	nc	Yes (a)	Yes (a)
Mn	µg/g	3600	nc	nc	Yes (a)	Yes (a)
Ni	µg/g	5690	5430	270	Yes	Yes
Pb	µg/g	30000	32	1100	Yes	Yes
Se	µg/g	16	5.5	10	Yes	Yes



Final – Environmental Risk Assessment for the Cameco Port Hope Conversion Facility

Parameter	Units	Max Soil Conc	MOE SCS Values		Retained as COPC for EcoRA?	
			Plants and Soil Invertebrates	Mammals and Birds	Plants and Soil Invertebrates	Mammals and Birds
Sb	µg/g	166	1470	40	No	Yes
Sr	µg/g	3000	nc	nc	Yes (a)	Yes (a)
U	µg/g	16800	33	2000	Yes	Yes
V	µg/g	150	18	200	Yes	No
Zn	µg/g	5500	337	600	Yes	Yes
<b>Radionuclides</b>						
Ra-226	Bq/g	32	nc	nc	Yes (b)	Yes (b)
<b>PHC</b>						
F1 (C6-C10)	µg/g	245	nc	320	Yes (a)	No
F2 (C10-C16)	µg/g	3200	nc	260	Yes (a)	Yes
F3 (C16-C34)	µg/g	140000	nc	1700	Yes (a)	Yes
<b>PCB</b>						
PCBs (Total)	µg/g	12	1.1	33	Yes	No

Notes:

MOE (2011) *Rationale for the Development of Soil and Groundwater Standards for use at Contaminated Sites in Ontario*. Appendix A2:

GW Table 3: Coarse Soil, Industrial/Commercial land use, Non-Potable.

nc - no component value available.

(a) - no component value; COPC carried forward in the assessment.

(b) - all radionuclides carried forward in the assessment.

As shown in Table 6.4, the following soil COPCs will be carried through the EcoRA:

(a) For plants and soil invertebrates:

Fluoride
Ammonia (Total)
Nitrite
Nitrate
Bromide
Chloride
Phosphate
Sulphate
Aluminum
Arsenic
Barium
Boron (Total)
Cadmium
Cobalt
Copper
Iron
Potassium
Magnesium
Manganese
Nickel
Lead
Selenium
Strontium
Uranium
Vanadium
Zinc
Radium-226
Petroleum Hydrocarbon fraction F1 (C6-C10)
Petroleum Hydrocarbon fraction F2 (C10-C16)
Petroleum Hydrocarbon fraction F3 (C16-C34)
PCBs (Total)

(a) For birds and mammals:

Fluoride
Ammonia (Total)
Nitrite
Nitrate
Bromide
Chloride
Phosphate
Sulphate
Aluminum
Arsenic
Barium
Boron (Total)
Cadmium
Cobalt
Copper
Iron
Potassium
Magnesium
Manganese
Nickel
Lead
Selenium
Antimony
Strontium
Uranium
Zinc
Radium-226
Petroleum Hydrocarbon fraction F2 (C10-C16)
Petroleum Hydrocarbon fraction F3 (C16-C34)

### 6.1.3.3 Overall List of COPCs for Ecological Risk Assessment

Based on the primary surface water screening and the secondary groundwater and soil screening conducted in the above sections, the following COPCs have been selected for the EcoRA:

Table 6.5 Overall List of COPCs for EcoRA

COPC	Pathways to be assessed		
	GW	Plants and Soil Invertebrates	Mammals and Birds
Fluoride	✓	✓	✓
Nitrite		✓	✓
Nitrate	✓	✓	✓
Ammonia (Total)	✓	✓	✓
Bromide		✓	✓
Chloride	✓	✓	✓
Phosphate		✓	✓
Sulphate	✓	✓	✓
TDS	✓		
Ag	✓		
Al	✓	✓	✓
As		✓	✓
Ba		✓	✓
B (total)		✓	✓
Ca	✓		
Cd		✓	✓
Co		✓	✓
Cu	✓	✓	✓
Fe	✓	✓	✓
K	✓	✓	✓
Mg	✓	✓	✓
Mn	✓	✓	✓
Na	✓		
Ni		✓	✓
Pb		✓	✓
Sb			✓
Se	✓	✓	✓
Sr	✓	✓	✓
U	✓	✓	✓
V		✓	
Zn	✓	✓	✓
Radionuclides (all)	✓	✓	✓
F1 (C6-C10)	✓	✓	
F2 (C10-C16)	✓	✓	✓
F3 (C16-C34)	✓	✓	✓
F4 (C34-C50)	✓		
PCBs (Total)		✓	

#### 6.1.4 EcoRA Exposure Pathways

Table 6.6 presents the active exposure pathways for the ecological receptors identified in Section 6.1.1. The exposure pathways are based on the known habitat needs, mobility, and diets of the ecological receptors, along with knowledge of the location of their respective habitats within the study area.

Terrestrial vegetation and terrestrial invertebrates (earthworms) would be directly exposed to contaminated soil. Similarly, aquatic vegetation and aquatic invertebrates (benthos) would be directly exposed to contaminated surface water and sediment.

Terrestrial mammals and birds are exposed through ingestion of food, including terrestrial vegetation and earthworms, as well as incidental ingestion of soil and ingestion of surface water. Higher trophic species such as great horned owl and red fox will also consume lower trophic species, such as voles, as part of their diet. Terrestrial mammals will also receive an external dose from soil (radiological only).

Aquatic birds are exposed through ingestion of food, including aquatic vegetation and benthos, as well as ingestion of sediment and surface water. Aquatic birds will also receive an external dose from radionuclides in surface water. Higher trophic species such as the horned grebe consume fish as part of their diet.

Pelagic fish would be directly exposed to contaminants in surface water, while benthic fish would be exposed to contaminants in surface water and would also receive an external dose from radionuclides in sediment. The exposure of fish to contaminants in storm water is assessed in Section 7.4; this is carried out as an acute assessment, to reflect the intermittent pulse releases associated with storm water.

The following pathways have been identified as inactive, or are otherwise not applicable for the ecological risk assessment:

- Inhalation;
- Dermal uptake; and
- Immersion in air (radiological only).

As discussed in CSA (2012), inhalation exposures are typically minor in relation to soil and food ingestion exposures, and can therefore be excluded from assessments. For particulate substances released to air and accumulating in the soil over time, the steady-state soil concentrations are usually high enough that soil and food ingestion components of dose are dominant.

Dermal exposure is generally not a significant pathway of exposure for wildlife as fur and feathers are effective at blocking direct contact with skin.

External dose from immersion in air is minor, relative to soil and food ingestion exposure and can be ignored (particularly since noble gases are not identified as COPCs) (CSA 2012).

Final – Environmental Risk Assessment for the Cameco Port Hope Conversion Facility

Table 6.6 EcoRA Exposure Pathways Summary

Receptor	Environmental Media Exposed	Modes of Exposure	Risk Calculation Method	
			Non-Radioactive	Radioactive
<i>Fish</i>	<ul style="list-style-type: none"> <li>• surface water</li> <li>• sediment</li> </ul>	<ul style="list-style-type: none"> <li>• uptake from water;</li> <li>• immersion in water;</li> <li>• exposure to sediment (benthic fish, radiological only).</li> </ul>	Comparison of surface water concentrations with corresponding benchmark values.	<p><b>Pelagic fish:</b></p> <ul style="list-style-type: none"> <li>• Internal dose from water;</li> <li>• External dose from water.</li> </ul> <p><b>Benthic fish:</b></p> <ul style="list-style-type: none"> <li>• Internal dose from water;</li> <li>• External dose from water;</li> <li>• External dose from sediment.</li> </ul>
<i>Benthic Invertebrates</i>	<ul style="list-style-type: none"> <li>• surface water</li> <li>• sediment</li> </ul>	<ul style="list-style-type: none"> <li>• uptake from water;</li> <li>• immersion in water (radiological only);</li> <li>• immersion in sediment (radiological only).</li> </ul>	Comparison of water concentrations with benchmark values.	<ul style="list-style-type: none"> <li>• Internal dose from water;</li> <li>• External dose from water;</li> <li>• External dose from sediment.</li> </ul>
<i>Aquatic Plants</i>	<ul style="list-style-type: none"> <li>• surface water</li> </ul>	<ul style="list-style-type: none"> <li>• uptake from water;</li> <li>• immersion in water (radiological only).</li> </ul>	Comparison of water concentrations with benchmark values.	<ul style="list-style-type: none"> <li>• Internal dose from water;</li> <li>• External dose from water.</li> </ul>
<i>Terrestrial Invertebrates</i>	<ul style="list-style-type: none"> <li>• soil</li> <li>• groundwater</li> </ul>	<ul style="list-style-type: none"> <li>• uptake from soil;</li> <li>• immersion in soil (radiological only);</li> <li>• uptake from groundwater;</li> <li>• immersion in groundwater (radiological only).</li> </ul>	Comparison of soil or groundwater concentrations with benchmark values.	<ul style="list-style-type: none"> <li>• Internal dose from soil or groundwater;</li> <li>• External dose from soil or groundwater.</li> </ul>
<i>Terrestrial Birds</i>	<ul style="list-style-type: none"> <li>• soil</li> <li>• surface water</li> </ul>	<ul style="list-style-type: none"> <li>• ingestion:                             <ul style="list-style-type: none"> <li>- terrestrial vegetation;</li> <li>- terrestrial invertebrates;</li> <li>- soil;</li> </ul> </li> </ul>	Comparison of dose from intake with benchmark values.	<ul style="list-style-type: none"> <li>• Internal dose from ingestion.</li> </ul>

Final – Environmental Risk Assessment for the Cameco Port Hope Conversion Facility

Receptor	Environmental Media Exposed	Modes of Exposure	Risk Calculation Method	
			Non-Radioactive	Radioactive
		<ul style="list-style-type: none"> <li>- surface water;</li> <li>- mammals (owl only).</li> <li>• direct exposure to soil (radiological only).</li> </ul>		
<i>Terrestrial Mammals</i>	<ul style="list-style-type: none"> <li>• soil</li> <li>• surface water</li> </ul>	<ul style="list-style-type: none"> <li>• ingestion:                             <ul style="list-style-type: none"> <li>- terrestrial invertebrates;</li> <li>- terrestrial vegetation;</li> <li>- soil;</li> <li>- surface water;</li> <li>- other mammals (fox only).</li> </ul> </li> <li>• direct exposure to soil (radiological only).</li> </ul>	Comparison of dose from intake with benchmark values.	<ul style="list-style-type: none"> <li>• Internal dose from ingestion;</li> <li>• External dose from soil.</li> </ul>
<i>Terrestrial Plants</i>	<ul style="list-style-type: none"> <li>• soil</li> </ul>	<ul style="list-style-type: none"> <li>• uptake from soil;</li> <li>• exposure to soil (radiological only).</li> </ul>	Comparison of soil concentrations with benchmark values.	<ul style="list-style-type: none"> <li>• Internal dose from soil;</li> <li>• External dose from soil.</li> </ul>
<i>Aquatic Birds</i>	<ul style="list-style-type: none"> <li>• surface water</li> <li>• sediment</li> </ul>	<ul style="list-style-type: none"> <li>• ingestion (as appropriate):                             <ul style="list-style-type: none"> <li>- surface water;</li> <li>- fish (grebe only);</li> <li>- benthic invertebrates;</li> <li>- aquatic vegetation;</li> <li>- sediment.</li> </ul> </li> <li>• immersion in surface water (radiological only).</li> </ul>	Comparison of dose from intake with benchmark values.	<ul style="list-style-type: none"> <li>• Internal dose from ingestion;</li> <li>• External dose from water.</li> </ul>

### **6.1.5 EcoRA Conceptual Site Model (CSM)**

The overall EcoRA study boundaries are based on knowledge of the site and surrounding area, and includes a range of known and potential contamination sources. However, as mentioned in the HHRA it is important to note that several sources of contamination exist, both on-site and off-site, and many are not related to current operations at the PHCF (e.g., on-site historical contamination). As such, many different sources contribute to the levels of contaminants identified in environmental media. This risk assessment focuses on ecological receptors and pathways relevant to current operations at the PHCF; as indicated in Figure 5.1, it does not focus on off-site and historical sources of contamination.

Table 6.7 outlines the environmental media included in this EcoRA along with the exposure pathways that link these environmental media to the identified ecological receptors.

Figure 6.2 presents a schematic conceptual site model based on the identified COPCs in environmental media (and the locations of these media), the identified ecological receptors, and the relevant exposure pathways.

Table 6.7 breaks down each environmental medium into its relevant locations, and indicates the ecological receptors that could potentially be exposed to each spatial area.

### **6.1.6 Tier Approach to EcoRA**

The EcoRA was carried out using a tiered approach, as follows. All relevant receptor-COPC combinations were assessed at a Tier 1 screening level, using conservative assumptions about environmental concentrations, ecological receptor characteristics and risk assessment parameters. For receptor-COPC combinations with exceedances at a Tier 1 level, Tier 2 EcoRA calculations were carried out, using more realistic concentrations, receptor characteristics and risk assessment parameters.



Figure 6.2. EcoRA Conceptual Site Model

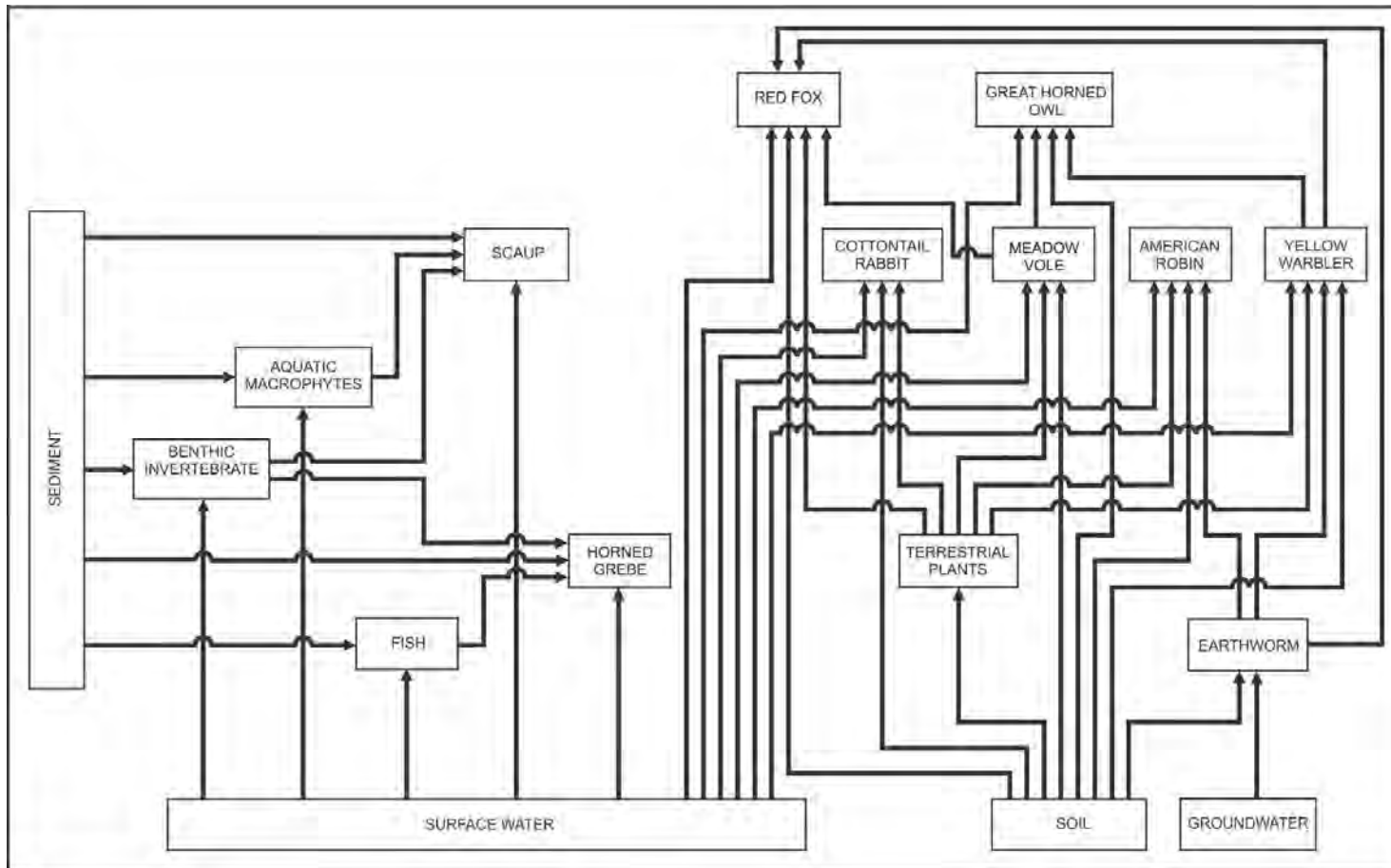

## 6.2 Exposure Assessment

### 6.2.1 Exposure Points

#### Terrestrial Environment and Biota:

As discussed earlier, terrestrial biota are potentially exposed to soil, surface water, and groundwater in the hypothetical case of the terrestrial invertebrate. There are few locations in the study area where soil is accessible to biota; these generally include:

1. **Off-Site Grass Strip:** a long, narrow strip of grass bounded by the harbour wall on the east and the industrial facility and fence on the west, with a second narrow extension running adjacent to the northern fenceline boundary of the site.
2. **On-Site Grass Patches:** isolated patches of landscaped grass interspersed among the industrial buildings and asphalt. These small grass patches are surrounded by the industrial site buildings and have limited access, as the facility boundary is fenced.
3. **On-Site Gravel Areas (inaccessible areas):** areas of compacted gravel among the industrial buildings; often used as unpaved transport routes for on-site worker pedestrians or vehicles. Access is limited as the facility boundary is fenced. This applies to both the PHCF and Dorset Street East sites.
4. **Off-Site Grass Areas** green space located in nearby parks and/or the yards of nearby residences, assumed to support selected terrestrial receptors. This applies to both the PHCF and Dorset Street East sites.

For the study area near the PHCF, the off-site grass strip (#1 above) is selected as the main exposure point for terrestrial biota, since the on-site grass patches (#2 above) are less accessible and less likely to provide for the habitat preferences of these receptors. The on-site grass patches (#2 above) are selected as a potential exposure point only for terrestrial vegetation and earthworms.

Table 6.7 provides a tabular outline of the terrestrial receptors, the on-site or off-site assessment areas they are associated with, and the corresponding environmental media they may be exposed to. Figure 6.3 presents a map of the different assessment areas, the ecological receptors assessed for each area, and the locations of the exposure points.

Table 6.7 Ecological Receptors, Exposure Points and Environmental Media

Assessment Area	Associated Ecological Receptors
<b>Groundwater (On-Site):</b> Applies to PHCF	Earthworm
<b>Off-Site Grass Strip:</b> Along harbour wall and northern end of the Site Applies to PHCF	Earthworm
	Terrestrial plants
	Meadow vole <sup>a</sup>
	Cotton-tail rabbit <sup>a</sup>
	Great horned owl <sup>a</sup>
	Red fox <sup>a</sup>
	Yellow warbler <sup>a</sup>
American robin <sup>a</sup>	
<b>On-Site Grass Patches:</b> Grass patches among facility buildings Applies to PHCF and Dorset Street East Site	Earthworm
	Terrestrial Vegetation
<b>On-site Gravel Areas (inaccessible areas):</b> Applies to PHCF and Dorset Street East Site	Earthworm
<b>Residential Yards:</b> Applies to PHCF and Dorset Street East Site	Earthworm
	Terrestrial Plants
	Meadow vole <sup>a</sup>
	Cotton-tail rabbit <sup>a</sup>
	Yellow warbler <sup>a</sup>
<b>Port Hope Harbour:</b> Surface water and sediment	Aquatic plants <sup>b</sup>
	Lesser scaup <sup>c</sup>
	Benthic invertebrates <sup>b</sup>
	Benthic fish <sup>b</sup>
	Pelagic fish
<b>Lake Ontario:</b> Surface water and sediment. Outlet of Harbour and Ganaraska River	Horned grebe <sup>c</sup>
	Horned grebe
	Aquatic plants <sup>b</sup>
	Benthic invertebrates <sup>b</sup>
	Benthic fish <sup>b</sup>
	Lesser scaup

Notes:

<sup>a</sup> Ingestion of surface water from Port Hope Harbour also considered.

<sup>b</sup> External exposure to sediment from Port Hope Harbour also considered.

<sup>c</sup> Ingestion of sediment from Port Hope Harbour also considered.

The exposure pathways for each ecological receptor are discussed in Section 4.2.3.

Figure 6.3. EcoRA: Receptor Locations and Exposure Points

(a) Near PHCF

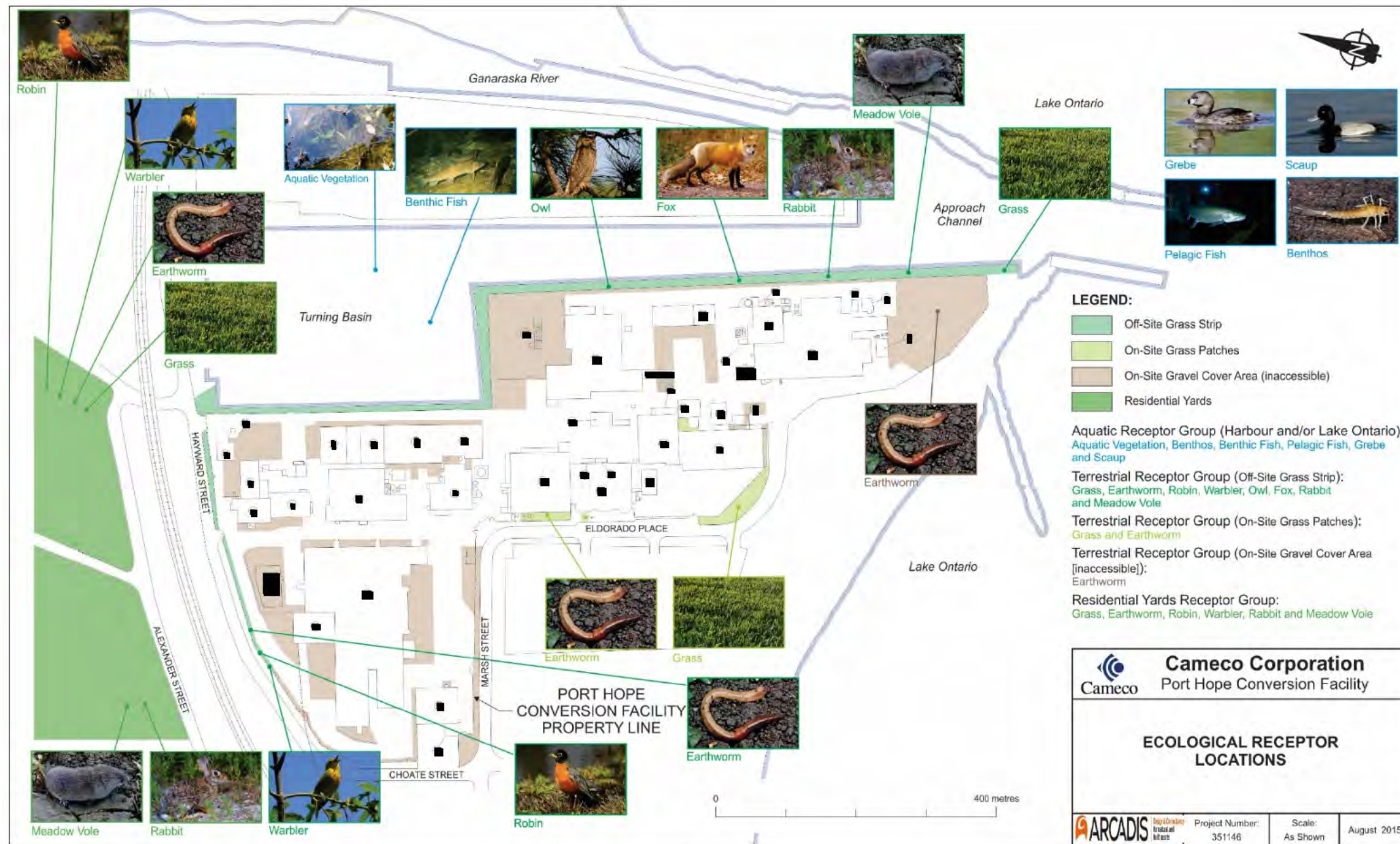

(b) Near Dorset Street East Site

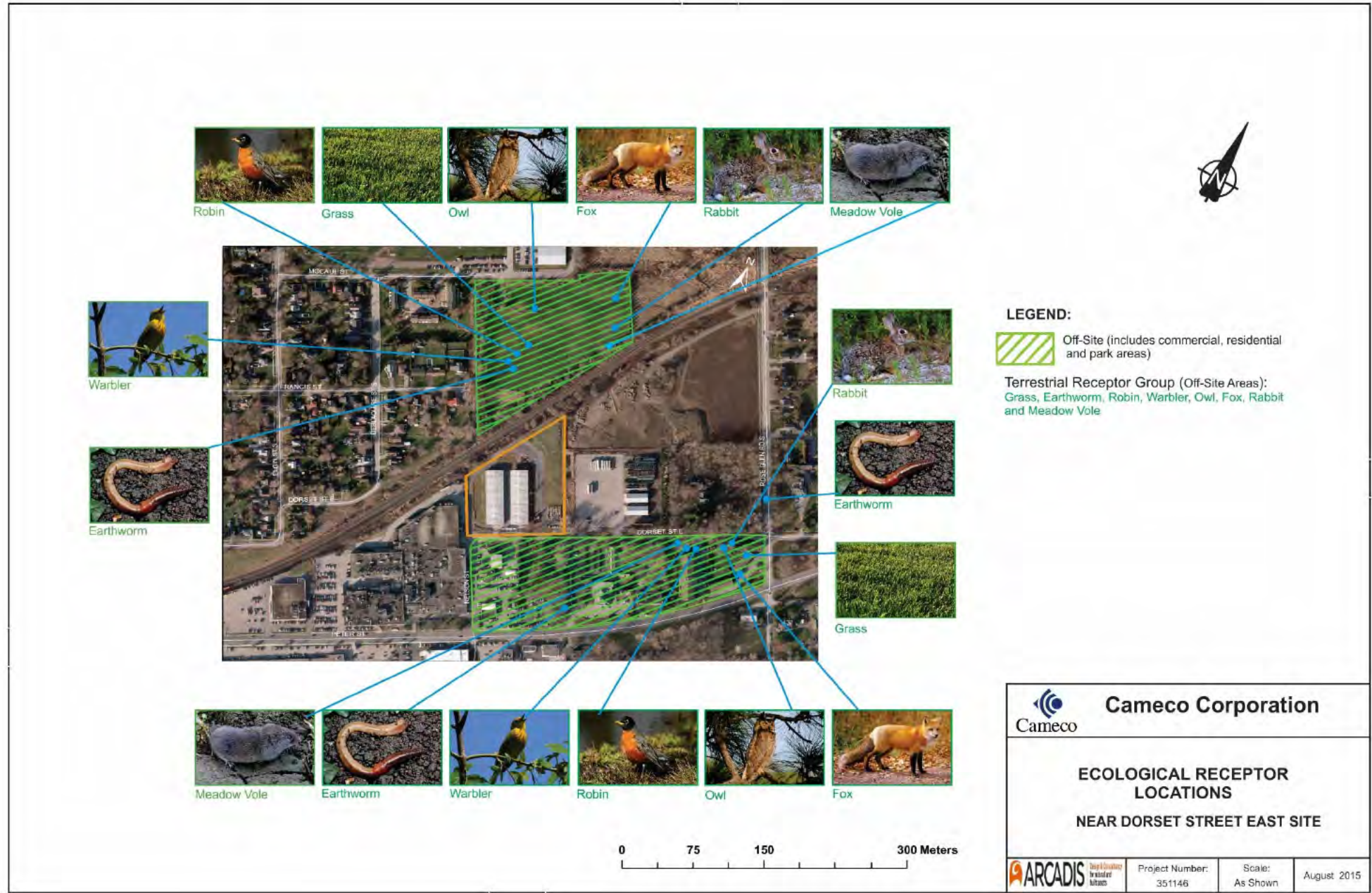

**Cameco Corporation**  
 Cameco

**ECOLOGICAL RECEPTOR LOCATIONS  
 NEAR DORSET STREET EAST SITE**

**ARCADIS** Project Number: 351146 Scale: As Shown August 2015

## 6.2.2 Exposure Factors for Receptors

Table 6.8 presents an overview of key exposure factors among the ecological receptors identified and described in Section 6.1.1.

The exposure factors for ecological receptors were obtained preferentially from Module C (*Standardization of Wildlife Receptor Characteristics*) of the Environment Canada (2012) *FCSAP Ecological Risk Assessment Guidance*. When not available from this source, the following resources were reviewed in order to select appropriate values:

- U.S. EPA (1993) *Wildlife Exposure Factors Handbook*.
- NatureServe (2009) *Explorer: An Online Encyclopedia of Life* (<http://www.natureserve.org/>).
- University of Michigan - Museum of Zoology: *Animal Diversity Web* (<http://animaldiversity.ummz.umich.edu/>; e.g., Kadlec 2003, Mikita 1999).
- Canadian Wildlife Service: Bird and Mammal Fact Sheets via Hinterland Who's Who (<http://www.hww.ca/en/>).

Soil and sediment ingestion rates were for the most part obtained from a wildlife soil ingestion study completed by Beyer *et al.* (1994) in which the fractional soil composition of the diets (i.e., percentage of the dry weight food ingestion rate) of 28 wildlife species were estimated. Ingestion rates for animals not considered in the Beyer study were estimated by using fractional compositions for other animals with similar diets.

When food and water intake and inhalation rates were not available directly from the above-mentioned sources, the following allometric equations from the U.S. EPA (1993) were used:

Dry weight food Ingestion (g dw/d):

$$\text{Birds} = 0.648 * \text{BW}^{0.651} \text{ (BW in g)}$$

$$\text{Mammals} = 0.235 * \text{BW}^{0.822} \text{ (BW in g)}$$

Water Intake (L/d):

$$\text{Birds} = 0.059 * \text{BW}^{0.67} \text{ (BW in kg)}$$

$$\text{Mammals} = 0.099 * \text{BW}^{0.9} \text{ (BW in kg)}$$

Inhalation Rate (m<sup>3</sup>/d):

$$\text{Birds} = 0.4089 * \text{BW}^{0.77} \text{ (BW in kg)}$$

$$\text{Mammals} = 0.5458 * \text{BW}^{0.8} \text{ (BW in kg)}$$

Final – Environmental Risk Assessment for the Cameco Port Hope Conversion Facility

Table 6.8 Overview of Exposure Factors for Ecological Receptors

Parameter	Units	Ecological Receptor (Source)															
		American Robin		Great Horned Owl		Horned Grebe		Lesser Scaup		Meadow Vole		Rabbit (Eastern Cottontail)		Red Fox		Yellow Warbler	
Body Weight	g	79	1	1500	3	435	4	707	1	34.9	1	1200	5	3800	1	10	6
Water Intake Rate	L/d	0.01*	1,2	0.08*	2	0.03*	2	0.05*	1,2	0.007	1,2	0.12	2	0.33*	1,2	0.003*	2
Inhalation Rate	m <sup>3</sup> /d	0.06*	2	0.56*	2	0.22*	2	0.31*	2	0.048*	2	0.64*	2	1.6*	2	0.012*	2
Soil Ingestion Rate	g (dw)/d	0.77	1	3.8	7	-	-	-	-	0.05	1	5	2	2.8	1	0.15	7
Sediment Ingestion Rate	g (dw)/d	-	-	-	-	0.7	7	1.5	1	-	-	-	-	-	-	-	-
Food Ingestion Rate	g (dw)/d	19.2	1,2	76*	2	34*	2	46.4*	1,2	2.3	1,2	79.8*	2	103	1,2	2.9*	2
Fraction that is fish	-	-	-	-	-	0.5	4	-	-	-	-	-	-	-	-	-	-
Fraction that is benthos	-	-	-	-	-	0.5	4	0.9	1	-	-	-	-	-	-	-	-
Fraction that is aq. vegetation	-	-	-	-	-	-	-	0.1	1	-	-	-	-	-	-	-	-
Fraction that is small mammals	-	-	-	0.8	8	-	-	-	-	-	-	-	-	0.4	1	-	-
Fraction that is birds	-	-	-	0.2	8	-	-	-	-	-	-	-	-	0.2	1	-	-

Final – Environmental Risk Assessment for the Cameco Port Hope Conversion Facility

Parameter	Units	Ecological Receptor (Source)															
		American Robin		Great Horned Owl		Horned Grebe		Lesser Scaup		Meadow Vole		Rabbit (Eastern Cottontail)		Red Fox		Yellow Warbler	
Fraction that is invertebrates	-	0.4	1	-	-	-	-	-	-	-	-	-	-	0.25	1	0.9 (insects)	6
Fraction that is terrestrial vegetation	-	0.6 (berries)	1	-	-	-	-	-	-	1	1	1	5	0.15	1	0.1 (berries)	6
Home Range	ha	0.7 to 28.3	1	800	10	0.033 to 3	9	10 to 1710	1	0.0069 to 0.348	1	3.1	2	280 to 3420	1	0.16	11

Notes:

\* Based on allometric equations from the U.S. EPA, 1993:

- 1. Environment Canada 2012
- 2. U.S. EPA 1993
- 3. Dietrich 2013
- 4. Handford 2001, Cornell 2011, NatureServe 2009
- 5. U.S. EPA 1993, Mikita 1999, NatureServe 2009
- 6. Cornell 2011, NatureServe 2009, Kadlec 2003
- 7. Beyer *et al.* 1994
  - a. great horned owl based on average soil ingestion rate of 5% of dry weight food ingestion rate for birds).
  - b. lesser scaup based on average sediment ingestion rate of 2% of dry weight food ingestion rate for blue-winged teal and ring-necked duck.
  - c. yellow warbler based on average soil ingestion rate of 5% of dry weight food ingestion rate for non-soil/sediment dwelling birds.
- 8. NatureServe 2009, CWS 1986
- 9. Handford 2001
- 10. Rohner 1997, CWS 1986
- 11. NatureServe 2009



### 6.2.3 Exposure Durations and Averaging

#### Terrestrial Receptors

For Tier 1 and Tier 2a EcoRA calculations, it is assumed that ecological receptors spend their entire exposure duration within their exposure locations, and that terrestrial mammals and birds obtain all of their food from the site. This is a conservative assumption, given that many species have larger home ranges or forage areas than the small grass patch areas of the site. Therefore, in Tier 1 and Tier 2a, the home range of any particular biota is assumed to be limited entirely to each exposure location. This approach is consistent with the SENES (2009a,b) SWRA versions.

In Tier 2b, however, risk calculations account for the fact that mobile receptors have an associated home range (area) in which they receive their intakes (e.g. feed, water, etc.). An exposure location (such as the off-site grass strip, or on-site gravel areas) accounts for only a portion of this overall homerange, depending on its size. For highly mobile receptors such as the American Robin, an exposure location can account for less than 10% of the home range, though the home range fraction will vary for each mobile receptor. Table 6.9 presents the home ranges of biota for which Tier 2b calculations are required (in this case, only the American robin), along with the area of the applicable exposure location (the off-site grass patch), and the resulting home range fraction.

Table 6.9 EcoRA – Home Range Fractions for Tier 2b

Receptor	Home Range (ha) <sup>a</sup>	Exposure Location	Approx. Exposure Location Area (ha)	Homerange Fraction
American Robin	0.7 to 28.3	Off-Site Grass Strip	0.0668	0.095

Notes:

a – from Table 6.8

For migratory species, risk calculations do *not* average a receptor's exposure based on time away from the site during migration.

#### Aquatic Receptors

Similar to terrestrial EcoRA calculations, Tier 1 and Tier 2a aquatic EcoRA calculations conservatively assume that all aquatic receptors spend their entire exposure duration within their exposure locations. Therefore, the home range of any particular biota is assumed to be limited entirely to each exposure location. This approach is consistent with the SENES (2009a,b) SWRA versions.

In Tier 2b, risk calculations account for the fact that mobile receptors (i.e. benthic and pelagic fish) have an associated home range (area) in which they, and the exposure location accounts for only a portion of this overall homerange. SENES (2013c) examined the movements and residency times of fish in the approach channel and in the Harbour using radiotelemetry tagging. Overall, SENES (2013c) found that 61% of all tagged fish spent none or less than 1% of their time in the approach channel or turning basin. Tagged fish use of the turning basin was limited with only three fish spending more than 1 hour there. The approach channel was frequented more than the turning basin with seven fish spending between 7 - 23% of their time

there. Since the SENES (2013c) residency results are based on salmonids (residency times will vary for each species) and they include time spent in the approach channel, for EcoRA calculation purposes an upper residency estimates (i.e. 23%) is used to represent the home range fraction for the Harbour exposure location (though results indicate that time spent within the harbour itself – excluding the approach channel – is very low).

Residency information – such as that which is available for the Harbour – is not available for the Lake/Beach exposure location. As such, residency fractions are not accounted for in Tier 2b calculations for mobile receptors within this area.

## 6.2.4 Exposure Point Concentrations

Sections 6.1.4 and 6.1.5 discuss the environmental media that each ecological receptor can be exposed to and the pathway through which they can potentially be exposed. Section 6.2.1 provides further detail, by identifying receptor locations within the study area, and distinguishing between the different spatial areas within each medium (e.g., while soil is a general environmental medium, it is further divided into discrete areas such as the off-site grass strip, on-site gravel areas, etc.).

The following tables present concentrations (including some summary statistics where relevant) for each distinct area of environmental media, relevant to the identified receptors and pathways. These concentrations/statistics are used as exposure point concentrations in subsequent exposure calculations.

It is important to note that for EcoRA calculations, measurement data for total ammonia must be converted into un-ionized ammonia, to allow for comparison to TRVs. For the Harbour exposure location, the conversion to un-ionized ammonia is based on the arithmetic mean of pH measurement data (8.147) and a temperature of 20°C, based on the SENES (2009a) SWRA. For the Lake/Beach exposure location, the conversion to un-ionized ammonia is based on the arithmetic mean of pH measurement data (8.211) and a temperature of 21.7°C, based on the SENES (2009a) SWRA.

In Tier 1, all depths of soil are considered. In the Tier 2b terrestrial assessments, soil depths beyond 0.5 meters below ground surface (mbgs) are excluded since the 0 - 0.5 mbgs soil depth represents the stratum inhabited by vegetation and soil invertebrates (i.e. the soil these receptors could be exposed to). When grouping soil data into depth categories, there were a small number of samples with either no depth information or ambiguous depth information (e.g. “X”). Since so few of these cases were observed (< 1%) any such samples were excluded from the categorization, though they are included in the Tier 1 and Tier 2a calculations which use soil data from all depths.

Final – Environmental Risk Assessment for the Cameco Port Hope Conversion Facility

Table 6.10 EcoRA – Harbour Sediment Concentrations

Analyte	Units	N	N<MDL	%<MDL	Minimum	Maximum	Arithmetic Mean	Geometric Mean	Std. Dev.	95th Percentile	95% UCLM
Aluminum	µg/g	26	0	0%	1900	19200	10388	8659	5340	17250	12177
Antimony	µg/g	4	3	75%	<0.2	0.4	0.18	0.14	0.15	0.36	N/A
Arsenic	µg/g	43	0	0%	0.8	800	57.0	14.5	143	185	152
Barium	µg/g	26	0	0%	16	170	97.6	81.1	48.2	150	139
Boron	µg/g	4	4	100%	<1	<1	<1	<1	0	<1	N/A
Cadmium	µg/g	26	6	23%	<0.1	0.6	0.36	0.26	0.22	0.60	0.46
Calcium	µg/g	22	0	0%	105	81700	31132	2095	35530	79740	64150
Chromium	µg/g	26	0	0%	3.8	37	16.5	14.1	8.54	29.0	19.4
Cobalt	µg/g	40	0	0%	1.2	85	11.3	8.00	13.2	24.2	20.4
Copper	µg/g	40	0	0%	1.7	180	38.5	26.2	29.3	61.3	58.7
Iron	µg/g	26	0	0%	4500	23900	14631	13015	6102	21475	19847
Lead	µg/g	40	0	0%	2.3	1800	172	68.9	323	606	394
Magnesium	µg/g	22	0	0%	2330	9000	5774	5293	2243	8558	6560
Nickel	µg/g	26	0	0%	0.7	29	12.8	8.83	8.18	26.0	15.5
Selenium	µg/g	4	0	0%	0.2	0.6	0.33	0.29	0.19	0.56	N/A
Silver	µg/g	26	6	23%	<0.1	2.8	0.68	0.35	0.81	2.7	0.99
Strontium	µg/g	26	0	0%	84	230	149	143	43.1	215	163
Uranium	µg/g	43	0	0%	0.3	338	37.8	10.9	59.1	114	56.4
Vanadium	µg/g	4	0	0%	20	34	26.3	25.8	5.80	32.8	N/A
Zinc	µg/g	26	0	0%	8.6	180	89.4	68.9	50.1	148	132
Pb-210	Bq/g	14	0	0%	2.5	71	8.85	4.68	18.0	30.6	29.8
Po-210 <sup>a</sup>	Bq/g	14	0	0%	2.5	71	8.85	4.68	18.0	30.6	29.8
Ra-224 <sup>b</sup>	Bq/g	N/A	N/A	N/A	N/A	0.025	N/A	N/A	N/A	N/A	N/A
Ra-226	Bq/g	31	4	13%	<0.02	103.3	5.74	0.75	18.6	16.6	20.4
Ra-228 <sup>a, b</sup>	Bq/g	N/A	N/A	N/A	N/A	0.025	N/A	N/A	N/A	N/A	N/A

Final – Environmental Risk Assessment for the Cameco Port Hope Conversion Facility

Analyte	Units	N	N<MDL	%<MDL	Minimum	Maximum	Arithmetic Mean	Geometric Mean	Std. Dev.	95th Percentile	95% UCLM
Th-228 <sup>b</sup>	Bq/g	N/A	N/A	N/A	N/A	0.15	N/A	N/A	N/A	N/A	N/A
Th-230	Bq/g	14	0	0%	4	110	14.4	8.03	27.7	48.3	46.6
Th-232 <sup>b</sup>	Bq/g	N/A	N/A	N/A	N/A	0.15	N/A	N/A	N/A	N/A	N/A
U-234 <sup>c</sup>	Bq/g	N/A	N/A	N/A	N/A	4.2	N/A	N/A	N/A	N/A	N/A
U-235 <sup>c</sup>	Bq/g	N/A	N/A	N/A	N/A	0.19	N/A	N/A	N/A	N/A	N/A
U-238 <sup>c</sup>	Bq/g	N/A	N/A	N/A	N/A	4.2	N/A	N/A	N/A	N/A	N/A

The following analytes were identified as COPCs in other media, but do not have concentration data available in sediment: ammonia, fluoride, nitrate, nitrite, bromide, chloride, phosphate, sulphate, TDS, potassium, manganese, sodium, PHC fractions F1-F4, PCBs.

Note: Based on 2008-2009 data (SENES 2009b). Radionuclides from 2003 and 2008-9 data.

- <sup>a</sup> Based on secular equilibrium, Po-210 assumed equal to Pb-210 and Ra-228 assumed equal to Ra-224.
- <sup>b</sup> Sediment concentration estimated by applying K<sub>d</sub> (water-sediment equilibrium distribution coefficient) to harbour water concentration. Note: harbour water levels were below detection limit and therefore set to half of detection limit.
- <sup>c</sup> Estimated from natural uranium concentration, based on specific activity.

For statistical analysis, values below detection limit were set to half of detection limit.

N/A – Not Available, e.g., based on limited measurement count or lack of data.

Final – Environmental Risk Assessment for the Cameco Port Hope Conversion Facility

Table 6.11 EcoRA – Lake Ontario Beach Sediment Concentrations (Estimated)

Analyte	Units	Kd Used	Kd Ref	Minimum	Maximum	Arithmetic Mean	Geometric Mean	95th Percentile
Ammonia (Total)	mg N/kgDW		NA	-	-	-	-	-
Antimony	mg/kgDW	5000	<sup>1</sup>	< 1.00	< 1.00	< 1.00	< 1.00	< 1.00
Arsenic	mg/kgDW	10	<sup>1</sup>	0.011	0.014	0.0123	0.0123	0.014
Barium	mg/kgDW	990	<sup>1</sup>	27.4	32.3	29.8	29.8	31.9
Cobalt	mg/kgDW	43000	<sup>1</sup>	1.94	2.41	2.12	2.12	2.37
Chromium	mg/kgDW	84	<sup>1</sup>	< 0.042	0.059	0.027	0.025	0.051
Iron	mg/kgDW	2200	<sup>1</sup>	< 22	< 22	< 22	< 22	< 22
Manganese	mg/kgDW	490	<sup>1</sup>	0.16	1.01	0.51	0.38	0.96
Nickel	mg/kgDW	4000	<sup>1</sup>	2.8	3.2	3	2.993	3.2
Lead	mg/kgDW	270	<sup>2</sup>	< 0.0054	0.0432	0.0108	0.0074	0.030
Selenium	mg/kgDW	1500	<sup>1</sup>	< 1.5	< 1.5	< 1.5	< 1.5	< 1.5
Silver	mg/kgDW	95000	<sup>1</sup>	< 0.95	1.9	0.76	0.67	1.47
Strontium	mg/kgDW	190	<sup>1</sup>	32.5	34.0	33.1	33.1	33.8
Uranium	mg/kgDW	50	<sup>1</sup>	0.031	0.047	0.037	0.037	0.044
Zinc	mg/kgDW	500	<sup>1</sup>	< 0.5	0.5	0.375	0.35	0.5
Ra-226	Bq/kgDW	7400	<sup>1</sup>	< 407	< 407	< 407	< 407	< 407
U-234 <sup>(a)</sup>	Bq/kgDW	NA		NA	0.0038	NA	NA	NA
U-235 <sup>(a)</sup>	Bq/kgDW	NA		NA	1.8E-04	NA	NA	NA
U-238 <sup>(a)</sup>	Bq/kgDW	NA		NA	0.0038	NA	NA	NA

Notes:

Beach sediment concentrations estimated using 2008-2009 beach surface water measurement data (SENES 2009b), and applying Kd values, where data and Kd values were available.

Radionuclide data (other than Ra-226) not available for these locations. Concentrations of U-238, U-234 and U-235 were estimated from total measured uranium concentration.

Kd values (L/kg DW) taken from: (1) CSA N288.1 (2014), TA.26; and (2) Bechtel Jacobs (1998).

The following analytes were identified as COPCs in other media, but are missing either concentration data in beach surface water, or Kd value, and could therefore not be used to estimate sediment concentrations: fluoride, nitrate, nitrite, bromide, chloride, phosphate, sulphate, TDS, potassium, magnesium, sodium, aluminum, boron, cadmium, calcium, copper, vanadium, PHC fractions F1-F4, PCBs.

For statistical analysis, values below detection limit were set to half of detection limit.

<sup>a</sup> Estimated from natural uranium concentration, based on specific activity.

NA – Not applicable.

Final – Environmental Risk Assessment for the Cameco Port Hope Conversion Facility

Table 6.12 EcoRA – Harbour Surface Water Concentrations

Analyte	Units	N	N <MDL	% <MDL	Minimum	Maximum	Arithmetic Mean	Geometric Mean	Std. Dev.	95th Percentile	95% UCLM
Fluoride	mg/L	104	0	0%	0.10	0.40	0.103	0.101	29.4	0.10	NC*
Ammonia (Total)	mg N/L	104	9	9%	<0.1	0.2	0.13	0.12	0.052	0.20	0.221
Nitrate	mg N/L	104	0	0%	0.3	1.1	1	1	0	1	NC
Nitrite	mg N/L	28	28	100%	<0.03	<0.03	<0.03	<0.03	0	<0.03	NC
Chloride	mg/L	28	0	0%	14	130	21	18	21	22	28
Sulphate	mg/L	28	0	0%	16	84	20	19	13	22	NC
TDS	mg/L	28	0	0%	200	271	239	238	18	268	NC
Aluminum	mg/L	33	0	0%	0.02	0.15	0.061	0.055	0.029	0.12	0.073
Antimony	mg/L	33	25	76%	<0.00007	0.00031	0.00012	0.00011	0.000060	0.00027	0.00024
Arsenic	mg/L	104	12	12%	<0.0012	0.0027	0.00166	0.00153	0.006	0.0026	1.85
Barium	mg/L	33	0	0%	0.0008	0.0139	0.0022	0.0018	0.0022	0.0032	0.047
Boron	mg/L	33	0	0%	0.019	0.045	0.024	0.023	0.0066	0.039	NC
Cadmium	mg/L	33	27	82%	<1.5E-06	0.000012	0.000003	0.000002	0.000002	0.000007	NC
Calcium	mg/L	33	0	0%	52.20	65.1	55	55	3	63	NC
Cobalt	mg/L	33	0	0%	0.000097	0.000218	0.00012	0.00012	0.000031	0.00018	NC
Chromium	mg/L	33	27	82%	<0.00025	0.0008	0.00032	0.00030	0.00016	0.00070	NC
Copper	mg/L	33	0	0%	0.001	0.0028	0.0016	0.0015	0.00041	0.0023	NC
Iron	mg/L	33	0	0%	0.05	0.28	0.14	0.13	0.058	0.28	0.17
Magnesium	mg/L	33	0	0%	9.74	11.3	10	10	0	11	NC
Manganese	mg/L	33	0	0%	0.0146	0.0431	0	0	0	0	0.036
Nickel	mg/L	33	0	0%	0.0002	0.0019	0.00056	0.00043	0.00051	0.0016	NC
Lead	mg/L	33	1	3%	<0.00001	0.00117	0.00048	0.00037	0.00028	0.0011	0.00062
Potassium	mg/L	33	0	0%	1.23	5.65	1	1	1	2	1.7
Selenium	mg/L	33	32	97%	<0.0005	0.001	0.00052	0.00051	0.000087	0.00050	NC
Silver	mg/L	33	27	82%	<0.000005	0.00006	0	0	0	0	NC
Sodium	mg/L	33	0	0%	8.93	12.6	10	10	1	12	NC

Final – Environmental Risk Assessment for the Cameco Port Hope Conversion Facility

Analyte	Units	N	N <MDL	% <MDL	Minimum	Maximum	Arithmetic Mean	Geometric Mean	Std. Dev.	95th Percentile	95% UCLM
Strontium	mg/L	33	0	0%	0.161	0.182	0.17	0.17	0.0060	0.18	0.17
Uranium	mg/L	104	0	0%	0.001	0.0078	0.00398	0.0037	1.69	0.0071	NC
Vanadium	mg/L	33	0	0%	0.00057	0.00129	0.0011	0.0011	0.00022	0.0013	NC
Zinc	mg/L	33	1	3%	<0.0005	0.008	0.0017	0.0014	0.0017	0.0060	0.0029
Pb-210	Bq/L	2	1	50%	<0.1	0.1	0.075	0.071	0.035	NC	NC
Po-210	Bq/L	2	2	100%	<0.01	<0.01	<0.01	<0.01	0.00	NC	NC
Ra-224	Bq/L	2	2	100%	<0.01	<0.01	<0.01	<0.01	0.00	NC	NC
Ra-226	mBq/L	103	99	96%	<55	110	30.2	29	12.7	27.5	NC
Ra-228 <sup>a</sup>	Bq/L	2	2	100%	<0.01	<0.01	<0.01	<0.01	0.00	NC	NC
Th-228	Bq/L	2	2	100%	<0.01	<0.01	<0.01	<0.01	0.00	NC	NC
Th-230	Bq/L	2	2	100%	<0.01	<0.01	<0.01	<0.01	0.00	NC	NC
Th-232	Bq/L	2	2	100%	<0.01	<0.01	<0.01	<0.01	0.00	NC	NC
U-234	Bq/L	3	1	33%	<0.1	0.115	0.075	0.070	0.035	NC	NC
U-235	Bq/L	3	2	67%	<0.01	0.01	0.0067	0.0063	0.0029	NC	NC
U-238	Bq/L	3	0	0%	0.07	0.11	0.087	0.085	0.021	NC	NC
U-238	Bq/L	3	0	0%	0.07	0.11	0.087	0.085	0.021	NC	NC

Note: Data for U, F, NH3, As, Ra-226 and NO3 are from Cameco 2014 EMP. Data for radionuclides and all other metals are from 2008-2009 (SENES 2009b).

The following analytes were identified as COPCs in other media, but do not have concentration data available in harbor surface water: bromide, phosphate, PHC fractions F1-F4, PCBs.

N/A – Not Available based on limited measurement count.

NC – not calculated, e.g., because Tier 2 evaluation not required for this COPC

NC\* – could not be calculated, e.g., because insufficient data available, or the available data set was unsuitable for the statistical calculations.

For statistical analysis, values below detection limit were set to half of detection limit.

<sup>a</sup> Ra-228 assumed equal to Ra-224, based on secular equilibrium.

Final – Environmental Risk Assessment for the Cameco Port Hope Conversion Facility

Table 6.13 EcoRA – Beach Surface Water Concentrations

Analyte	Units	N	N<MDL	%<MDL	Minimum	Maximum	Arithmetic Mean	95th Percentile	95% UCLM
Fluoride	mg/L	10	5	50%	<0.06	0.12	0.074	0.12	0.12
Nitrate	mg N/L	10	0	0%	0.29	0.43	0.327	0.403	NC
Nitrite	mg N/L	10	10	100%	<0.06	<0.06	<0.06	<0.06	NC
Chloride	mg/L	10	0	0%	25	29	27.1	29	28
Sulphate	mg/L	10	0	0%	23	28	25.2	27.1	NC
TDS	mg/L	10	0	0%	126	166	149.2	164.65	NC
Ammonia (Total)	mg N/L	10	9	90%	<0.1	0.1	0.055	0.0775	NC*
Aluminum	mg/L	10	4	40%	<0.01	0.07	0.021	0.061	NC
Antimony	mg/L	10	10	100%	<0.0002	<0.0002	<0.0002	<0.0002	NC
Arsenic	mg/L	10	0	0%	0.0011	0.0014	0.00123	0.001355	0.0013
Barium	mg/L	10	0	0%	0.0277	0.0326	0.03012	0.032195	NC
Boron	mg/L	10	5	50%	<0.002	0.034	0.02	0.0322	NC
Cadmium	mg/L	10	5	50%	<0.000003	0.000005	2.55E-06	0.00000455	NC
Calcium	mg/L	10	0	0%	34.5	37.3	35.51	36.58	NC
Cobalt	mg/L	10	0	0%	0.000045	0.000056	4.94E-05	0.0000551	NC
Chromium	mg/L	10	8	80%	<0.0005	0.0007	0.00032	0.00061	NC
Copper	mg/L	10	0	0%	0.0009	0.0011	0.00095	0.001055	NC
Iron	mg/L	10	10	100%	<0.01	<0.01	<0.01	<0.01	NC
Magnesium	mg/L			0%	8.48	9.2	8.757	9.0695	NC
Manganese	mg/L	10	0	0%	0.00033	0.00207	0.001039	0.001953	NC
Nickel	mg/L	10	0	0%	0.0007	0.0008	0.00075	0.0008	NC
Lead	mg/L	10	3	30%	<0.00002	0.00016	0.00004	0.0001105	NC
Potassium	mg/L			0%	1.7	1.96	1.822	1.9465	NC
Selenium	mg/L	10	10	100%	<0.001	<0.001	<0.001	<0.001	NC
Silver	mg/L	10	6	60%	<0.00001	0.00002	0.000008	0.0000155	NC
Sodium	mg/L			0%	12.6	13.6	12.92	13.375	NC
Strontium	mg/L	10	0	0%	0.171	0.179	0.1743	0.17765	0.18
Uranium	mg/L	10	0	0%	0.000623	0.000934	0.000741	0.0008863	0.0008
Vanadium	mg/L	10	0	0%	0.00044	0.00068	0.000569	0.0006755	NC
Zinc	mg/L	10	5	50%	<0.001	0.001	0.00075	0.001	NC



Final – Environmental Risk Assessment for the Cameco Port Hope Conversion Facility

Analyte	Units	N	N<MDL	%<MDL	Minimum	Maximum	Arithmetic Mean	95th Percentile	95% UCLM
Ra-226	Bq/L	10	10	100%	<0.055	<0.055	<0.055	<0.055	NC
U-238 <sup>a</sup>	Bq/L	NA	NA	NA	NA	0.0115	NA	NA	NA
U-234 <sup>a</sup>	Bq/L	NA	NA	NA	NA	0.0115	NA	NA	NA
U-235 <sup>a</sup>	Bq/L	NA	NA	NA	NA	5.3E-04	NA	NA	NA

Notes:

Beach surface water concentrations are based on 2008-2009 data (SENES 2009b).

The following analytes were identified as COPCs in other media, but do not have concentration data available in harbor surface water: bromide, phosphate, PHC fractions F1-F4, PCBs.

Radionuclide data (other than Ra-226) not available for these locations. Concentrations of U-238, U-234 and U-235 were estimated from total measured uranium concentration.

<sup>a</sup> Calculated from total uranium, using specific activity.

NA – not applicable.

NC – not calculated.

NC\* – could not be calculated, e.g., because insufficient data available, or the available data set was unsuitable for the statistical calculations.

ND – no data.

For statistical analysis, values below detection limit were set to half of detection limit.

Final – Environmental Risk Assessment for the Cameco Port Hope Conversion Facility

Table 6.14 EcoRA – Soil Concentrations (Off-Site Residential Stations, PHCF & Dorset St East)

Analyte	Maximum Measured Soil Concentration, All Depths (µg/g unless otherwise indicated)					95 <sup>th</sup> Percentile  (All locations and depths)	95% UCLM  (All locations and depths)
	Station #	1	2	12	19		
NO2+NO3		25	28	25	25	25	NC
Aluminum		8500	25400	15900	17700	14500	24160
Antimony		1.9	0.3	7.3	0.8	27.0	10.74
Arsenic		26	4	57	10	17	39.4
Barium		41	140	92	130	110	140
Boron		11	32	130	25	24	31.4
Cadmium		0.30	0.40	1.00	0.50	0.30	0.90
Chromium		16	39	29	25	28	37.6
Cobalt		5.8	9.3	25.0	6.4	5.2	15.4
Copper		15	16	66	20	11	60.4
Iron		16700	27000	31700	20400	17800	26940
Lead		44	12	420	211	270	390.4
Manganese		340	570	410	450	370	548
Molybdenum		0.40	0.80	5.20	0.70	1.70	1.64
Nickel		6.40	12.00	35.00	14.00	8.50	28.8
Selenium		0.20	0.40	1.00	0.80	0.30	0.78
Silver		0.40	0.10	0.90	0.20	0.20	0.48
Strontium		180.0	110.0	190.0	140.0	140.0	190

Final – Environmental Risk Assessment for the Cameco Port Hope Conversion Facility

Analyte	Maximum Measured Soil Concentration, All Depths (µg/g unless otherwise indicated)					95 <sup>th</sup> Percentile (All locations and depths)	95% UCLM (All locations and depths)	
	Station #	1	2	12	19			25
U		10.0	1.4	9.2	3.5	7.6	8.9	NC
V		29	58	36	38	34	56.8	NC
Zn		70	66	500	150	170	240	206
U-238 <sup>a</sup> (Bq/g)		0.12	0.017	0.11	0.043	0.094	0.11	NC
U-234 <sup>a</sup> (Bq/g)		0.12	0.017	0.11	0.043	0.094	0.11	NC
U-235 <sup>a</sup> (Bq/g)		0.0057	0.0008	0.0052	0.002	0.0043	0.0051	NC

Note:

NC – not calculated, e.g., because Tier 2 assessment of this contaminant was not required.

For calculation of maximum and 95<sup>th</sup> percentile values, values below detection limit were set to half of detection limit.

Based on Cameco 2014 Annual Soil Monitoring results.

The following analytes were identified as COPCs, but do not have concentration data available in off-site locations: fluoride, ammonia, bromide, chloride, bromide, phosphate, sulphate, TDS, calcium, potassium, magnesium, sodium, radionuclides, PHC fractions F1-F4, PCBs.

For Tier 1 calculations, all soil depths considered.

Radionuclide data not available for these locations. Concentrations of U-238, U-234 and U-235 were estimated from total measured uranium concentration.

<sup>a</sup> Calculated from total uranium, using specific activity.

Final – Environmental Risk Assessment for the Cameco Port Hope Conversion Facility

Table 6.15 EcoRA – Soil Concentrations (PHCF Off-Site Grass Strip)

Soil – Off-Site Grass Strip Only	Units	N	N<MDL	%<MDL	Minimum	Maximum	Arithmetic Mean	Geometric Mean	Std. Dev.	95th Percentile	95% UCLM
Fluoride	ug/g	22	0	0%	1	1450	186	26.1	379	1145	691
Ammonia (Total)	ug/g	11	4	36%	<40	910	208	85.0	290	728	376
Aluminum	ug/g	366	0	0	510	16000	2946	2344	2192	7200	3445
Arsenic	ug/g	589	21	4%	<0.5	1550	18.2	2.95	95	65	35
Barium	ug/g	376	0	0%	5.2	431	42.1	25.2	58	130	55
Boron (Total)	ug/g	365	5	1%	<3	120	5.99	4.39	9	14	7
Cadmium	ug/g	376	77	20%	<0.02	1.8	0.11	0.055	0	0	0
Cobalt	ug/g	376	2	1%	<0.8	2730	11.6	2.46	142	9	27
Chromium	ug/g	376	0	0%	0.9	51	7.09	5.31	6	18	8
Copper	ug/g	376	0	0%	0.8	8830	35.6	5.03	457	42	138
Iron	ug/g	355	0	0%	1900	130000	7267	5348	10940	16000	9798
Nickel	ug/g	376	0	0%	1.6	5690	24.5	6.22	295	19.0	90.9
Lead	ug/g	374	2	1%	<1.96	30000	166	6.94	1792	89.7	570
Potassium	ug/g	355	0	0%	190	12000	791	560	1088	1800	1043
Magnesium	ug/g	355	0	0%	180	22000	3901	3494	1804	6930	NC
Manganese	ug/g	366	0	0%	8	1900	183	153	156	378	218
Antimony	ug/g	365	209	57%	<0.1	166	0.83	0.12	8.79	1.48	1.80
Selenium	ug/g	365	197	54%	<0.7	16	0.80	0.61	1.06	1.98	0.98
Strontium	ug/g	366	0	0%	9.1	510	176	146	102	388	199
Uranium	ug/g	594	0	0%	0.16	3390	32.2	4.14	173	120	63.1
Vanadium	ug/g	376	0	0%	1.5	126	9.35	6.91	10.6	23.0	11.7
Zinc	ug/g	376	0	0%	3.7	1000	36.9	19.5	81.0	105	55.1
F1 (C6-C10)	ug/g	4	3	75%	<5	245	63.1	7.87	121	209	NC
F2 (C10-C16)	ug/g	8	6	75%	<10	3200	472	20.2	1118	2272	NC <sup>b</sup>
F3 (C16-C34)	ug/g	7	3	43%	<10	140000	20048	96.8	52894	98060	NC
F4 (C34-C50)	ug/g	8	6	75%	<10	1700	306	42.5	604	1329	NC
PCBs (Total)	ug/g	5	2	40%	<0.01	12	2.76	0.32	5.19	9.84	NC
Pb-210	Bq/g	8	0	0%	0.2	0.7	0.44	0.39	0.20	0.70	NC
Po-210	Bq/g	11	0	0%	0.05	0.72	0.33	0.23	0.25	0.69	0.47
Ra-224	ND										

Final – Environmental Risk Assessment for the Cameco Port Hope Conversion Facility

Soil – Off-Site Grass Strip Only	Units	N	N<MDL	%<MDL	Minimum	Maximum	Arithmetic Mean	Geometric Mean	Std. Dev.	95th Percentile	95% UCLM
Ra-226	Bq/g	44	6	14%	<0.01	32	1.97	0.13	6.16	17.2	11.2
Ra-228	ND										
Th-228	Bq/g	27	12	44%	<0	0.04	0.012	NC	0.011	0.040	0.034
Th-230	Bq/g	29	0	0%	0.01	7.4	1.17	0.34	1.82	5.44	2.00
Th-232	Bq/g	25	8	32%	<0.01	0.1	0.016	0.012	0.019	0.028	NC
U-234 <sup>a</sup>	Bq/g	NC	NC	NC	NC	41.9	NC	NC	NC	NC	NC
U-235 <sup>a</sup>	Bq/g	NC	NC	NC	NC	1.93	NC	NC	NC	NC	NC
U-238	Bq/g	11	0	0%	0.05	4.6	0.92	0.43	1.29	3.00	2.23

Notes:

The following analytes do not have available data in this medium/location: ammonia, nitrate, nitrite, bromide, chloride, phosphate, sulphate, radionuclides, PHCs, PCBs.

ND – No data. Analyte not measured in this particular environmental medium, but identified in others as a COPC in other media (food chain link).

NC – Not calculated.

N/A – Not Available based on limited measurement count.

For statistical analysis, values below detection limit were set to half of detection limit.

<sup>a</sup> Calculated from total uranium, using specific activity.

<sup>b</sup> There was insufficient data to calculate a 95% UCLM for PHC F2; however, a value was needed for the Tier 2 calculations. Therefore, the 95<sup>th</sup> percentile concentration (2272 µg/g) was applied in Tier 2.

The incremental leachate soil concentrations for arsenic are 3.6 µg/g (vegetation) and 6.65 µg/g (earthworms).

Final – Environmental Risk Assessment for the Cameco Port Hope Conversion Facility

Table 6.16 EcoRA – Soil Concentrations (PHCF On-Site Grass Patches)

Soil - On-Site Only Grass Patches Only	Units	N	N<MDL	%<MDL	Minimum	Maximum	Arithmetic Mean	Geometric Mean	Std. Dev.	95th Percentile	95% UCLM
Fluoride	ug/g	2	0	0%	35.2	36.4	35.8	35.8	0.85	36.3	NC
Nitrate	ug/g	2	0	0%	0.7	4	2.35	1.67	2.33	3.84	NC
Aluminum	ug/g	7	0	0%	1800	6700	3443	3002	2052	6490	4950
Arsenic	ug/g	25	0	0%	1	52	8.52	4.07	12.9	35.2	19.8
Barium	ug/g	7	0	0%	11	51	23.4	19.9	15.6	47.7	NC
Boron (Total)	ug/g	7	0	0%	3	16	6.71	5.93	4.23	13.0	NC
Cadmium	ug/g	7	4	57%	<0.02	0.82	0.16	0.035	0.30	0.63	NC
Cobalt	ug/g	7	0	0%	1.1	4.6	2.30	2.07	1.21	4.18	NC
Chromium	ug/g	7	0	0%	2.6	9.7	4.83	4.49	2.24	8.14	NC
Copper	ug/g	7	0	0%	1.9	13	5.30	4.40	3.80	11.3	NC
Iron	ug/g	7	0	0%	3400	14000	6500	5744	3841	12590	9321
Potassium	ug/g	7	0	0%	520	3100	1104	913	904	2500	2302
Magnesium	ug/g	7	0	0%	2900	8000	4786	4525	1775	7280	NC
Manganese	ug/g	7	0	0%	160	530	249	228	131	458	345
Sodium	ug/g	7	0	0%	120	220	164	160	40	214	NC
Nickel	ug/g	7	0	0%	2.7	6.4	4.87	4.69	1.37	6.34	NC
Lead	ug/g	7	0	0%	2.5	14	4.66	3.79	4.16	11.0	NC
Antimony	ug/g	7	3	43%	<0.1	0.2	0.11	0.091	0.067	0.20	NC
Selenium	ug/g	7	6	86%	<0.7	1.7	0.59	0.49	0.50	1.34	NC
Strontium	ug/g	7	0	0%	99	270	201	191	61.8	264	NC
Uranium	ug/g	25	0	0%	0.39	24	5.16	2.26	6.96	19.8	11.8
Vanadium	ug/g	7	0	0%	4	16	8.43	7.49	4.39	14.8	NC
Zinc	ug/g	7	0	0%	4.9	37	20.4	17.5	10.8	35.2	NC

Final – Environmental Risk Assessment for the Cameco Port Hope Conversion Facility

Soil - On-Site Only Grass Patches Only	Units	N	N<MDL	%<MDL	Minimum	Maximum	Arithmetic Mean	Geometric Mean	Std. Dev.	95th Percentile	95% UCLM
U-234 <sup>a</sup>	Bq/g	NC	NC	NC	NC	0.3	NC	NC	NC	NC	NC
U-235 <sup>a</sup>	Bq/g	NC	NC	NC	NC	0.3	NC	NC	NC	NC	NC
U-238 <sup>a</sup>	Bq/g	NC	NC	NC	NC	0.014	NC	NC	NC	NC	NC

The following analytes do not have available data in this medium/location: ammonia, nitrite, bromide, chloride, phosphate, sulphate, radionuclides, PHCs, PCBs.

NC - Not calculated, e.g., based on limited measurement count.

For statistical analysis, values below detection limit were set to half of detection limit.

Radionuclide data not available for these locations. Concentrations of U-238, U-234 and U-235 were estimated from total measured uranium concentration.

<sup>a</sup> Calculated from total uranium, using specific activity.

Final – Environmental Risk Assessment for the Cameco Port Hope Conversion Facility

Table 6.17 EcoRA – Soil Concentrations (PHCF On-Site Gravel Areas)

Soil - On-Site Only Granular & Gravel Surfaces	Units	N	N<MDL	%<MDL	Minimum	Maximum	Arithmetic Mean	Geometric Mean	Std. Dev.	95th Percentile	95% UCLM
Fluoride	ug/g	102	3	3%	<1	470	64.5	9.65	126	359	142
Ammonia (Total)	ug/g	80	55	69%	<40	2030	98.3	35.0	290	283	169
Nitrate	ug/g	98	75	77%	<0.3	18	1	1	2	2	NC
Nitrite	ug/g	80	80	100%	<2	<2	<2	<2	0	<2	NC
Bromide	ug/g	80	80	100%	<5	<10	<5.06	<5.04	0	<5	NC
Chloride	ug/g	80	11	14%	<5	696	33	13	87	101	75.2
Sulphate	ug/g	80	1	1%	<2	14700	516	56	2301	804	NC
Phosphate	ug/g	80	69	86%	<10	135	9	6	17	24	NC
Aluminum	ug/g	151	0	0%	880	35000	3601	2772	3948	8915	5002
Arsenic	ug/g	316	4	1%	<1	780	11.8	2.96	57	32	26
Barium	ug/g	151	1	1%	<5	210	32.7	23.2	32	98	37
Boron (Total)	ug/g	71	9	13%	<2	35	5.04	3.78	6	11	6
Cadmium	ug/g	151	97	64%	<0.02	6.9	0.23	0.11	1	0	0
Cobalt	ug/g	151	29	19%	<1.4	102	3.48	2.15	9	8	5
Chromium	ug/g	151	0	0%	1.4	110	8.43	6.29	11	20	12
Copper	ug/g	151	0	0%	0.6	528	12.4	4.83	46	31	29
Iron	ug/g	151	0	0%	2000	130000	8984	6698	12751	20900	13507
Potassium	ug/g	151	0	0%	187	5000	771	622	635	1555	842
Magnesium	ug/g	151	0	0%	372	23000	4564	4134	2530	7775	NC
Manganese	ug/g	151	0	0%	50	3600	246	194	366	412	NC
Sodium	ug/g	151	0	0%	76	10000	270	174	823	436	NC
Nickel	ug/g	151	20	13%	<2	334	8.32	4.29	28	25	14
Lead	ug/g	151	33	22%	<2	612	22.8	6.11	70	96	48
Antimony	ug/g	71	50	70%	<0.1	14	0.50	0.13	2	1	1
Selenium	ug/g	71	54	76%	<0.7	2.3	0.61	0.50	0	2	1
Strontium	ug/g	151	0	0%	19	517	198	178	92	398	211
Uranium	ug/g	341	0	0%	0.23	1350	31.1	4.39	117	127	59
Vanadium	ug/g	151	0	0%	1.2	130	12.3	9.56	13	27	17
Zinc	ug/g	151	0	0%	4.9	281	34.4	22.0	43	120	50



Final – Environmental Risk Assessment for the Cameco Port Hope Conversion Facility

Soil - On-Site Only Granular & Gravel Surfaces	Units	N	N<MDL	%<MDL	Minimum	Maximum	Arithmetic Mean	Geometric Mean	Std. Dev.	95th Percentile	95% UCLM
Pb-210							ND				
Po-210							ND				
Ra-224							ND				
Ra-226	Bq/g	143	32	22%	<0.01	15	0.28	0.029	1.42	0.48	1.02
Ra-228							ND				
Th-228	Bq/g	1	1	100%	<0.01	<0.01	<0.01	<0.01	0	<0.01	NC
Th-230	Bq/g	1	0	0%	0.16	0.16	0.16	0.16	0	0.16	NC
Th-232	Bq/g	1	1	100%	<0.01	<0.01	<0.01	<0.01	0	<0.01	NC
U-234 <sup>a</sup>	Bq/g	NC	NC	NC	NC	16.7	NC	NC	NC	NC	NC
U-235 <sup>a</sup>	Bq/g	NC	NC	NC	NC	0.77	NC	NC	NC	NC	NC
U-238 <sup>a</sup>	Bq/g	NC	NC	NC	NC	16.7	NC	NC	NC	NC	NC

Notes:

The following analytes do not have available data in this medium/location: PHCs, PCBs and some radionuclides.

NC – Not calculated, e.g., based on limited measurement count.

For statistical analysis, values below detection limit were set to half of detection limit.

Table 6.18 EcoRA – Groundwater Concentrations (PHCF)

Analyte	Units	Maximum Measured	95 <sup>th</sup> Percentile	95% UCLM
F	mg/L	75.00	9.7	NC
Total Dissolved Solids	mg/L	158000.00	5598	NC
SO4	mg/L	1200.00	210	NC
Cl	mg/L	82000.00	3500	1765
NO3	as N mg/L	115.00	17.8	NC
NH3+NH4	as N mg/L	150.00	25.9	NC
Ag	mg/L	0.03	0.0024	NC
Al	mg/L	0.22	0.067	NC
Ca	mg/L	12200.00	515	NC
Cu	mg/L	0.29	0.091	NC
Fe	mg/L	36.70	14.1	6.64
K	mg/L	1080.00	402	NC
Mg	mg/L	5190.00	76.1	NC
Mn	mg/L	2.60	1.26	0.38
Na	mg/L	23700.00	1716	694
Se	mg/L	0.54	0.024	0.035
Sr	mg/L	1090	3.89	60.3
U	mg/L	21	6.8	1.96
Zn	mg/L	2.20	0.216	NC
F1 (C6-C10) - water	µg/L	103	50	NC
F2 (C10-C16) - water	µg/L	4440.00	50	NC
F3 (C16-C34) - water	µg/L	1720.00	653.1	NC
F4 (C34-C50) - water	µg/L	1120.00	250	NC
Ra-226	mBq/L	890.0	134	NC
Pb-210	Bq/L	2	NC	NC
Po-210	Bq/L	0.03	NC	NC
Ra-224 <sup>b</sup>	Bq/L	8	NC	NC
Ra-228	Bq/L	8	NC	NC

Final – Environmental Risk Assessment for the Cameco Port Hope Conversion Facility

Analyte	Units	Maximum Measured	95 <sup>th</sup> Percentile	95% UCLM
Th-228	Bq/L	0.1	NC	NC
Th-230	Bq/L	0.08	NC	NC
Th-232	Bq/L	0.02	NC	NC
U-234	Bq/L	1350	NC	NC
U-235	Bq/L	40	NC	NC
U-238	Bq/L	1420	NC	NC

Notes:

Groundwater data for petroleum hydrocarbons and radionuclides (except Ra-226) are from 2008 sampling. Groundwater data for VOCs (other than TCE and its products) are from 2013 sampling. All other data, including Ra-226 and TCE and its products, are from 2014 sampling (the greater of Cameco in-house and 2014 Groundwater Report).

<sup>b</sup> Assumed equal to Ra-228, secular equilibrium. See Table 2.1.

For statistical analysis, values below detection limit were set to half of DL.

ND – No data.

NC – Not calculated (e.g., because Tier 2 assessment not required for this contaminant).

## 6.2.5 Non-Radiological Dose Calculation Methods

The COPCs identified through the screening process (see Sections 3.0 and 6.1.3) are quantitatively evaluated for all ecological receptors (see Section 6.1.1), based on the identified pathways (see Section 6.1.4 and environmental media (see Section 6.2.1). Where sufficient data are not available, a qualitative assessment is undertaken.

For terrestrial vegetation and earthworms, toxicity is based on direct comparison to soil COPC concentrations; an examination of the intakes for these receptors is not necessary. Similarly, assessment of potential effects on aquatic biota via contact with surface water is based on direct comparison to surface water COPC concentrations; exposure modelling is not required.

For mammals and birds, COPC exposure is based on intakes, which are estimated by way of food chain intake calculations. In a broad sense, the total intake of any given COPC for a particular mammal or bird receptor is equal to the sum of intakes from all appropriate pathways, including: incidental ingestion of soil, incidental ingestion of surface water, and consumption of food (which varies based on the diet of a particular receptor). Equation 6-1 is used to calculate each of the intake routes as follows:

$$I_n = C_n \times IR_n \times f_{loc} \times CF \quad (6-1)$$

Where:

$I_n$  = intake of COPC via pathway “n” where “n” can represent all exposure routes such as soil, vegetation, etc. [mg/d]

$C_n$  = COPC concentration in “n” media [mg/kg]

$IR_n$  = intake rate of “n” by the receptor [g/d]

$f_{loc}$  = fraction of time at site [-]

$CF$  = conversion factor  $1.0 \times 10^{-3}$  [kg/g]

After summing the individual intakes, the total intake was divided by the body weight of the ecological receptor in order to compare the total COPC intake to the toxicity reference value (which has the unit of mg/kg-d). This is consistent with CSA (2012) methodology for calculating intakes.

### 6.2.5.1 Hypothetical Groundwater Invertebrate Method

Biota reside in surface water and surface soil, and do not have direct access to groundwater. Biota exposure to groundwater occurs only once the groundwater has migrated into surface water. This is captured in the EcoRA through the use of surface water data, which implicitly include the contributions from groundwater.

Despite the above, groundwater quality can also be assessed (for perspective only) using a hypothetical terrestrial invertebrate (earthworm). TRVs for groundwater are not typically available. Therefore, soil TRVs

(expressed as a soil concentration) are obtained for the desired COPCs and converted into corresponding groundwater TRV values, using soil-water equilibrium distribution coefficients (Kd values). The measured groundwater concentration can then be compared to the groundwater TRV, to calculate a screening index and evaluate risk (details on risk evaluation are provided in Section 6.4).

## 6.2.6 Radiological Dose Calculation Methods

For radionuclide COPCs, the resulting radiation dose involves both internal and external components, which are calculated separately. The total radiation dose, per radionuclide, is the sum of all internal and external doses. The overall radiation dose is the total sum of all internal external doses from all radionuclides, in addition to external gamma dose (from measured levels). The estimation of dose from radon is discussed in Section 6.4.2.

### 6.2.6.1 Aquatic Biota – Internal & External Radiation Dose

For aquatic biota, the internal dose calculation is performed for each radionuclide, following Equation 6-2 (CSA 2012):

$$D_{int} = DC_{int} \times C_{tissue} \quad (6-2)$$

Where:

$D_{int}$  = internal radiation dose [ $\mu$ Gy/hr]

$DC_{int}$  = internal dose coefficient for radionuclide in tissue [ $\mu$ Gy/hr per Bq/(kg fw)]

$C_{tissue}$  = whole body tissue concentration [Bq/(kg fw)]

The external dose calculation is performed for each radionuclide, following Equation 6-3 (CSA 2012):

$$D_{ext} = DC_{ext} [(OF_w + 0.5 \times OF_{ws} + 0.5 \times OF_{ss}) \times C_w + (OF_s + 0.5 \times OF_{ss}) \times C_s] \quad (6-3)$$

Where:

$D_{ext}$  = external radiation dose [ $\mu$ Gy/hr]

$DC_{ext}$  = external dose coefficient for radionuclide in water or sediment [ $\mu$ Gy/hr per Bq/kg; or  $\mu$ Gy/hr per Bq/L]

$OF_w$  = fraction of time spent immersed in surface water [unitless]

- OF<sub>s</sub> = fraction of time spent immersed in sediment [unitless]
- OF<sub>ws</sub> = fraction of time spent on the water's surface [unitless]
- OF<sub>ss</sub> = fraction of time spent on the sediment's surface [unitless]
- C<sub>w</sub> = surface water concentration [Bq/L]
- C<sub>s</sub> = sediment concentration [Bq/kg]

### 6.2.6.2 Terrestrial Biota – Internal & External Radiation Dose

For terrestrial biota, internal dose calculation is performed for each radionuclide, following Equation 6-4 (CSA 2012):

$$D_{\text{int}} = DC_{\text{int}} \times C_{\text{tissue}} \quad (6-4)$$

Where:

- D<sub>int</sub> = internal radiation dose [μGy/hr]
- DC<sub>int</sub> = internal dose coefficient for radionuclide in tissue [μGy/hr per Bq/(kg fw)]
- C<sub>tissue</sub> = whole body tissue concentration [Bq/(kg fw)]

External dose calculation is performed for each radionuclide, following Equation 6-5 (CSA 2012):

$$D_{\text{ext}} = DC_{\text{ext}} \times OF_{\text{soil}} \times C_{\text{soil}} \quad (6-5)$$

Where:

- D<sub>ext</sub> = external radiation dose [μGy/hr]
- DC<sub>ext</sub> = external dose coefficient for radionuclide in soil [μGy/hr per Bq/kg]
- OF<sub>soil</sub> = fraction of time spent immersed in soil [unitless]
- C<sub>soil</sub> = soil concentration [Bq/kg]

### 6.2.6.3 Radiation Weighting Factors

The radioecological weighting factor, also referred to as relative biological effectiveness (RBE), is the ratio of doses from different types of radiation needed to produce the same biological effect. For example,

$$\text{Alpha RBE} = \frac{\text{(Dose of gamma to produce a given effect)}}{\text{(Dose of alpha to produce the same effect)}}$$

The RBE is applied to un-weighted doses from alpha-emitting radionuclides; the weighted doses retain their original units (i.e., mGy/day). A RBE factor of 10 is used in this study for the alpha radiation component of internal dose from all alpha emitting radionuclides, following CSA (2012). Select dose coefficients (DCs, see next section) from Prohl (2003) already include an RBE of 10 (see below), whereas DCs from Amiro (1997) are not originally weighted. In this study, an RBE of 10 has been applied to DCs for all alpha emitting radionuclides, including DCs from Amiro (1997) and Prohl (2003).

### 6.2.6.4 Dose Coefficients

Radiation dose coefficients (DCs) have been selected from Prohl (2003), consistent with CSA (2012) guidance.

Prohl (2003) provides DCs from the FASSET program based on select reference organisms, which have been chosen by based on broad taxonomic families of organisms that are known contributors to the proper functioning of an ecosystem. The following reference organisms are considered in Prohl (2003):

#### Terrestrial Reference Organisms:

- Woodlouse;
- Earthworm;
- Mouse;
- Mole;
- Weasel;
- Snake;
- Rabbit;
- Red fox;
- Row deer;
- Cattle;
- Small egg;
- Big egg;
- Herbivorous bird;
- Carnivorous bird.

Aquatic Reference Organisms Phytoplankton:

- Zooplankton;
- Crustacean;
- Insect larvae;
- Vascular plant;
- Gastropod;
- Amphibian;
- Bivalve mollusc;
- Pelagic fish;
- Benthic fish;
- Mammal;
- Bird.

Table 6.19 presents a comparison between Prohl (FASSET) (2003) reference organism classes and the identified ecological receptors.

Table 6.19 Comparison of Ecological Receptors to Reference Organisms (for DCs)

Prohl (2003) Reference Organism	Applicable Y/N	Ecological Receptor Equivalency	Comments
<b>Terrestrial Biota</b>			
Earthworm	Y	Earthworm	-
Mouse	Y	Meadow Vole	Representative species
Rabbit	Y	Eastern Cotton-Tail Rabbit	Representative species.
Red fox	Y	Red Fox	-
Herbivorous bird (terrestrial)	Y	American Robin Yellow Warbler	Prohl (2003) DCs are based on organism size/dimensions, not diet. According to Prohl (2003), DCs for the 'carnivorous bird' reference organism are based on an organism equivalent in volume to a rabbit, whereas DCs for the 'herbivorous bird' reference organism are based on an organism with volume similar to a mouse. The herbivorous bird DCs are therefore chosen preferentially, since this more closely matches the size of a robin and warbler, and, the herbivorous bird DCs are generally more conservative than those derived for carnivorous birds.



Prohl (2003) Reference Organism	Applicable Y/N	Ecological Receptor Equivalency	Comments
Carnivorous bird (terrestrial)	Y	Great Horned Owl	Prohl (2003) DCs are based on organism size/dimensions. According to Prohl (2003), DCs for the 'carnivorous bird' reference organism are based on an organism approximately equivalent in size to a rabbit. The carnivorous bird/rabbit DCs therefore appropriately approximate the size of the owl receptor. See further discussion below.
Terrestrial Plants (Critical Organs)	Y	Terrestrial Vegetation	See discussion below.
<b>Aquatic Biota</b>			
Insect larvae	Y	Benthos	Benthos includes crustaceans such as crayfish, mollusks such as clams and snails, aquatic worms and the immature (larval) forms of aquatic insects such as stonefly and mayfly nymphs. Bivalve mollusk DCs were chosen.
Gastropod			
Bivalve mollusc			
Vascular plant	Y	Aquatic Vegetation (generic)	Representative species.
Pelagic fish	Y	Pelagic Fish (generic)	Representative group.
Benthic fish	Y	Benthic Fish (generic)	Representative group.
Aquatic Bird	Y	Horned Grebe Lesser Scaup	Many representative species. Both predatory and herbivorous species are represented. Aquatic bird DCs will be used preferentially for these receptors, where available.

Overall, there is good alignment; however, there are two biota groups that warrant further discussion: terrestrial vegetation, and terrestrial birds.

#### Terrestrial Vegetation

For terrestrial vegetation, DCs for whole-body exposure are not available in Prohl (2003). Instead Prohl (2003) provides organ-specific terrestrial vegetation DCs (external) for selected critical organs of shrubs, trees and herbs (meristems and buds). By applying the DC for a sensitive critical organ to the estimated whole-body exposure, the resulting dose will have an inherent degree of conservatism. Therefore, the critical organ DC for the ‘herb’ reference organism was selected. Prohl (2003) does not provide internal DCs for terrestrial vegetation; internal DCs from Amiro (1997) were applied.

#### Terrestrial Birds

For terrestrial birds, DCs for internal exposure are not available from Prohl (2003). However, DCs from Prohl (2003) are derived primarily based on organism size, which is simplified and expressed ellipsoids or spheres of various sizes. Prohl (2003) lists the organism size for the ‘herbivorous bird’ reference organism as being equal to that of the ‘mouse’ reference organism. Similarly, Prohl (2003) lists the organism size for the ‘carnivorous bird’ reference organism as being equal to that of the ‘rabbit’ reference organism. Therefore, the Prohl (2003) internal exposure DCs for these two receptor pairs are interchangeable. As a result, the internal DCs for the ‘mouse’ reference organism are applied to the American Robin and Yellow Warbler receptors, whereas the internal DCs for the ‘rabbit’ reference organism are applied to the Great Horned Owl receptor.

Table 6.20 presents the internal and external DCs selected for the ecological receptors.

Table 6.20 EcoRA: Dose Coefficients – Terrestrial Biota, Internal

Terrestrial Receptor	Radio-nuclide	Internal DCs (weighted) (Gy/y per Bq/kgFW)	Reference Information
American Robin	Pb-210	2.19E-06	Prohl (2003) [Mouse]
	Po-210	2.72E-04	Prohl (2003) [Mouse]
	Ra-224	1.49E-03	Amiro (1997) RBE=10
	Ra-226	1.23E-03	Prohl (2003) [Mouse]
	Ra-228	7.12E-06	Amiro (1997)
	Th-228	1.58E-03	Prohl (2003) [Mouse]
	Th-230	2.37E-04	Prohl (2003) [Mouse]
	Th-232	2.01E-04	Prohl (2003) [Mouse]
	U-234	2.37E-04	Prohl (2003) [Mouse]
	U-235	2.28E-04	Prohl (2003) [Mouse]
Cottontail Rabbit	U-238	2.10E-04	Prohl (2003) [Mouse]
	Pb-210	2.19E-06	Prohl (2003) [Rabbit]
	Po-210	2.72E-04	Prohl (2003) [Rabbit]
	Ra-224	1.49E-03	Amiro (1997) RBE=10
	Ra-226	1.23E-03	Prohl (2003) [Rabbit]
	Ra-228	7.12E-06	Amiro (1997)
	Th-228	1.58E-03	Prohl (2003) [Rabbit]
	Th-230	2.37E-04	Prohl (2003) [Rabbit]
	Th-232	2.01E-04	Prohl (2003) [Rabbit]
	U-234	2.37E-04	Prohl (2003) [Rabbit]
Earthworm (soil)	U-235	2.28E-04	Prohl (2003) [Rabbit]
	U-238	2.10E-04	Prohl (2003) [Rabbit]
	Pb-210	2.10E-06	Prohl (2003) [Earthworm]
	Po-210	2.72E-04	Prohl (2003) [Earthworm]
	Ra-224	1.49E-03	Amiro (1997) RBE=10
	Ra-226	1.23E-03	Prohl (2003) [Earthworm]
	Ra-228	7.12E-06	Amiro (1997)
	Th-228	1.58E-03	Prohl (2003) [Earthworm]
	Th-230	2.37E-04	Prohl (2003) [Earthworm]
	Th-232	2.01E-04	Prohl (2003) [Earthworm]
U-234	2.37E-04	Prohl (2003) [Earthworm]	
U-235	2.28E-04	Prohl (2003) [Earthworm]	
U-238	2.10E-04	Prohl (2003) [Earthworm]	

Final – Environmental Risk Assessment for the Cameco Port Hope Conversion Facility

Terrestrial Receptor	Radio-nuclide	Internal DCs (weighted) (Gy/y per Bq/kgFW)	Reference Information	
Great Horned Owl	Pb-210	2.19E-06	Prohl (2003) [Rabbit]	
	Po-210	2.72E-04	Prohl (2003) [Rabbit]	
	Ra-224	1.49E-03	Amiro (1997) RBE=10	
	Ra-226	1.23E-03	Prohl (2003) [Rabbit]	
	Ra-228	7.12E-06	Amiro (1997)	
	Th-228	1.58E-03	Prohl (2003) [Rabbit]	
	Th-230	2.37E-04	Prohl (2003) [Rabbit]	
	Th-232	2.01E-04	Prohl (2003) [Rabbit]	
	U-234	2.37E-04	Prohl (2003) [Rabbit]	
	U-235	2.28E-04	Prohl (2003) [Rabbit]	
	U-238	2.10E-04	Prohl (2003) [Rabbit]	
	Meadow Vole	Pb-210	2.19E-06	Prohl (2003) [Mouse]
		Po-210	2.72E-04	Prohl (2003) [Mouse]
Ra-224		1.49E-03	Amiro (1997) RBE=10	
Ra-226		1.23E-03	Prohl (2003) [Mouse]	
Ra-228		7.12E-06	Amiro (1997)	
Th-228		1.58E-03	Prohl (2003) [Mouse]	
Th-230		2.37E-04	Prohl (2003) [Mouse]	
Th-232		2.01E-04	Prohl (2003) [Mouse]	
U-234		2.37E-04	Prohl (2003) [Mouse]	
U-235		2.28E-04	Prohl (2003) [Mouse]	
U-238		2.10E-04	Prohl (2003) [Mouse]	
Red Fox		Pb-210	2.28E-06	Prohl (2003) [Red Fox]
		Po-210	2.72E-04	Prohl (2003) [Red Fox]
	Ra-224	1.49E-03	Amiro (1997) RBE=10	
	Ra-226	1.23E-03	Prohl (2003) [Red Fox]	
	Ra-228	7.12E-06	Amiro (1997)	
	Th-228	1.58E-03	Prohl (2003) [Red Fox]	
	Th-230	2.37E-04	Prohl (2003) [Red Fox]	
	Th-232	2.01E-04	Prohl (2003) [Red Fox]	
	U-234	2.37E-04	Prohl (2003) [Red Fox]	
	U-235	2.28E-04	Prohl (2003) [Red Fox]	
	U-238	2.10E-04	Prohl (2003) [Red Fox]	

Final – Environmental Risk Assessment for the Cameco Port Hope Conversion Facility

Terrestrial Receptor	Radio-nuclide	Internal DCs (weighted) (Gy/y per Bq/kgFW)	Reference Information	
Vegetation	Pb-210	2.17E-07	Amiro (1997)	
	Po-210	2.73E-04	Amiro (1997) RBE=10	
	Ra-224	1.49E-03	Amiro (1997) RBE=10	
	Ra-226	2.46E-04	Amiro (1997) RBE=10	
	Ra-228	7.12E-06	Amiro (1997)	
	Th-228	2.79E-04	Amiro (1997) RBE=10	
	Th-230	2.41E-04	Amiro (1997) RBE=10	
	Th-232	2.06E-04	Amiro (1997) RBE=10	
	U-234	2.46E-04	Amiro (1997) RBE=10	
	U-235	2.36E-04	Amiro (1997) RBE=10	
	U-238	2.16E-04	Amiro (1997) RBE=10	
	Yellow Warbler	Pb-210	2.19E-06	Prohl (2003) [Mouse]
		Po-210	2.72E-04	Prohl (2003) [Mouse]
Ra-224		1.49E-03	Amiro (1997) RBE=10	
Ra-226		1.23E-03	Prohl (2003) [Mouse]	
Ra-228		7.12E-06	Amiro (1997)	
Th-228		1.58E-03	Prohl (2003) [Mouse]	
Th-230		2.37E-04	Prohl (2003) [Mouse]	
Th-232		2.01E-04	Prohl (2003) [Mouse]	
U-234		2.37E-04	Prohl (2003) [Mouse]	
U-235		2.28E-04	Prohl (2003) [Mouse]	
U-238	2.10E-04	Prohl (2003) [Mouse]		

Table 6.21 EcoRA: Dose Coefficients – Terrestrial Biota, External

Terrestrial Receptors	Radio-nuclide	External DCs (Gy/y per Bq/kgDW)	Reference Information
American Robin	Pb-210	1.58E-09	Prohl (2003) [Herbivorous Bird] <sup>a</sup>
	Po-210	1.40E-11	Prohl (2003) [Herbivorous Bird] <sup>a</sup>
	Ra-224	1.16E-05	Amiro (1997)
	Ra-226	2.80E-06	Prohl (2003) [Herbivorous Bird] <sup>a</sup>
	Ra-228	7.10E-06	Amiro (1997)
	Th-228	2.37E-06	Prohl (2003) [Herbivorous Bird] <sup>a</sup>
	Th-230	6.13E-10	Prohl (2003) [Herbivorous Bird] <sup>a</sup>
	Th-232	3.77E-10	Prohl (2003) [Herbivorous Bird] <sup>a</sup>
	U-234	4.38E-10	Prohl (2003) [Herbivorous Bird] <sup>a</sup>
	U-235	2.37E-07	Prohl (2003) [Herbivorous Bird] <sup>a</sup>
Cottontail Rabbit	U-238	2.80E-10	Prohl (2003) [Herbivorous Bird] <sup>a</sup>
	Pb-210	2.63E-09	Prohl (2003) [Rabbit] <sup>a</sup>
	Po-210	1.31E-11	Prohl (2003) [Rabbit] <sup>a</sup>
	Ra-224	1.16E-05	Amiro (1997)
	Ra-226	2.72E-06	Prohl (2003) [Rabbit] <sup>a</sup>
	Ra-228	7.10E-06	Amiro (1997)
	Th-228	2.28E-06	Prohl (2003) [Rabbit] <sup>a</sup>
	Th-230	9.64E-10	Prohl (2003) [Rabbit] <sup>a</sup>
Earthworm (soil)	Th-232	7.10E-10	Prohl (2003) [Rabbit] <sup>a</sup>
	U-234	8.67E-10	Prohl (2003) [Rabbit] <sup>a</sup>
	U-235	2.28E-07	Prohl (2003) [Rabbit] <sup>a</sup>
	U-238	6.39E-10	Prohl (2003) [Rabbit] <sup>a</sup>
	Pb-210	1.66E-09	Prohl (2003) [Earthworm] <sup>b</sup>
	Po-210	2.01E-11	Prohl (2003) [Earthworm] <sup>b</sup>
	Ra-224	1.16E-05	Amiro (1997)
	Ra-226	4.03E-06	Prohl (2003) [Earthworm] <sup>b</sup>
	Ra-228	7.10E-06	Amiro (1997)
	Th-228	3.50E-06	Prohl (2003) [Earthworm] <sup>b</sup>
	Th-230	4.82E-10	Prohl (2003) [Earthworm] <sup>b</sup>
	Th-232	2.28E-10	Prohl (2003) [Earthworm] <sup>b</sup>
	U-234	2.54E-10	Prohl (2003) [Earthworm] <sup>b</sup>
	U-235	2.54E-07	Prohl (2003) [Earthworm] <sup>b</sup>
	U-238	1.31E-10	Prohl (2003) [Earthworm] <sup>b</sup>

Final – Environmental Risk Assessment for the Cameco Port Hope Conversion Facility

Terrestrial Receptors	Radio-nuclide	External DCs (Gy/y per Bq/kgDW)	Reference Information
Great Horned Owl	Pb-210	1.05E-09	Prohl (2003) [Carnivorous Bird] <sup>a</sup>
	Po-210	1.14E-11	Prohl (2003) [Carnivorous Bird] <sup>a</sup>
	Ra-224	1.16E-05	Amiro (1997)
	Ra-226	2.28E-06	Prohl (2003) [Carnivorous Bird] <sup>a</sup>
	Ra-228	7.10E-06	Amiro (1997)
	Th-228	1.93E-06	Prohl (2003) [Carnivorous Bird] <sup>a</sup>
	Th-230	3.68E-10	Prohl (2003) [Carnivorous Bird] <sup>a</sup>
	Th-232	1.84E-10	Prohl (2003) [Carnivorous Bird] <sup>a</sup>
	U-234	1.75E-10	Prohl (2003) [Carnivorous Bird] <sup>a</sup>
	U-235	1.93E-07	Prohl (2003) [Carnivorous Bird] <sup>a</sup>
	U-238	8.23E-11	Prohl (2003) [Carnivorous Bird] <sup>a</sup>
	Meadow Vole	Pb-210	1.66E-09
Po-210		2.01E-11	Prohl (2003) [Mouse] <sup>b</sup>
Ra-224		1.16E-05	Amiro (1997)
Ra-226		4.03E-06	Prohl (2003) [Mouse] <sup>b</sup>
Ra-228		7.10E-06	Amiro (1997)
Th-228		3.50E-06	Prohl (2003) [Mouse] <sup>b</sup>
Th-230		4.82E-10	Prohl (2003) [Mouse] <sup>b</sup>
Th-232		2.28E-10	Prohl (2003) [Mouse] <sup>b</sup>
U-234		2.54E-10	Prohl (2003) [Mouse] <sup>b</sup>
U-235		2.54E-07	Prohl (2003) [Mouse] <sup>b</sup>
U-238		1.31E-10	Prohl (2003) [Mouse] <sup>b</sup>
Red Fox		Pb-210	2.28E-09
	Po-210	1.23E-11	Prohl (2003) [Red Fox] <sup>a</sup>
	Ra-224	1.16E-05	Amiro (1997)
	Ra-226	2.54E-06	Prohl (2003) [Red Fox] <sup>a</sup>
	Ra-228	7.10E-06	Amiro (1997)
	Th-228	2.19E-06	Prohl (2003) [Red Fox] <sup>a</sup>
	Th-230	8.32E-10	Prohl (2003) [Red Fox] <sup>a</sup>
	Th-232	6.31E-10	Prohl (2003) [Red Fox] <sup>a</sup>
	U-234	7.71E-10	Prohl (2003) [Red Fox] <sup>a</sup>
	U-235	2.10E-07	Prohl (2003) [Red Fox] <sup>a</sup>
	U-238	5.69E-10	Prohl (2003) [Red Fox] <sup>a</sup>

Final – Environmental Risk Assessment for the Cameco Port Hope Conversion Facility

Terrestrial Receptors	Radio-nuclide	External DCs (Gy/y per Bq/kgDW)	Reference Information	
Vegetation	Pb-210	3.16E-09	Prohl (2003) [Herb]	
	Po-210	1.49E-11	Prohl (2003) [Herb]	
	Ra-224	1.16E-05	Amiro (1997)	
	Ra-226	2.89E-06	Prohl (2003) [Herb]	
	Ra-228	7.10E-06	Amiro (1997)	
	Th-228	2.45E-06	Prohl (2003) [Herb]	
	Th-230	1.14E-09	Prohl (2003) [Herb]	
	Th-232	8.42E-10	Prohl (2003) [Herb]	
	U-234	1.05E-09	Prohl (2003) [Herb]	
	U-235	2.72E-07	Prohl (2003) [Herb]	
	U-238	7.80E-10	Prohl (2003) [Herb]	
	Yellow Warbler	Pb-210	1.58E-09	Prohl (2003) [Herbivorous Bird] <sup>a</sup>
		Po-210	1.40E-11	Prohl (2003) [Herbivorous Bird] <sup>a</sup>
Ra-224		1.16E-05	Amiro (1997)	
Ra-226		2.80E-06	Prohl (2003) [Herbivorous Bird] <sup>a</sup>	
Ra-228		7.10E-06	Amiro (1997)	
Th-228		2.37E-06	Prohl (2003) [Herbivorous Bird] <sup>a</sup>	
Th-230		6.13E-10	Prohl (2003) [Herbivorous Bird] <sup>a</sup>	
Th-232		3.77E-10	Prohl (2003) [Herbivorous Bird] <sup>a</sup>	
U-234		4.38E-10	Prohl (2003) [Herbivorous Bird] <sup>a</sup>	
U-235		2.37E-07	Prohl (2003) [Herbivorous Bird] <sup>a</sup>	
U-238		2.80E-10	Prohl (2003) [Herbivorous Bird] <sup>a</sup>	

Notes:

<sup>a</sup> DCs for external exposure of organisms that live *on soil*.

<sup>b</sup> DCs for external exposure of organisms that live *in soil*.



Table 6.22 EcoRA: Dose Coefficients – Aquatic Biota, Internal

Aquatic Receptors	Radio-nuclide	Internal DC (Gy/y per Bq/kgFW)	Reference Information	
Aquatic Vegetation	Pb-210	4.82E-07	Prohl (2003) [Vascular Plant]	
	Po-210	2.72E-04	Prohl (2003) [Vascular Plant], RBE=10	
	Ra-224	1.49E-03	Amiro (1997), RBE=10	
	Ra-226	1.49E-03	Prohl (2003) [Vascular Plant], RBE=10	
	Ra-228	7.12E-06	Amiro (1997)	
	Th-228	1.58E-03	Prohl (2003) [Vascular Plant], RBE=10	
	Th-230	2.37E-04	Prohl (2003) [Vascular Plant], RBE=10	
	Th-232	2.01E-04	Prohl (2003) [Vascular Plant], RBE=10	
	U-234	2.37E-04	Prohl (2003) [Vascular Plant], RBE=10	
	U-235	2.28E-04	Prohl (2003) [Vascular Plant], RBE=10	
	U-238	4.64E-04	Prohl (2003) [Vascular Plant], RBE=10	
	Benthic Fish	Pb-210	2.10E-06	Prohl (2003) [Benthic Fish]
		Po-210	2.72E-04	Prohl (2003) [Benthic Fish], RBE=10
Ra-224		1.49E-03	Amiro (1997), RBE=10	
Ra-226		1.58E-03	Prohl (2003) [Benthic Fish], RBE=10	
Ra-228		7.12E-06	Amiro (1997)	
Th-228		1.66E-03	Prohl (2003) [Benthic Fish], RBE=10	
Th-230		2.37E-04	Prohl (2003) [Benthic Fish], RBE=10	
Th-232		2.01E-04	Prohl (2003) [Benthic Fish], RBE=10	
U-234		2.37E-04	Prohl (2003) [Benthic Fish], RBE=10	
U-235		2.28E-04	Prohl (2003) [Benthic Fish], RBE=10	
U-238		4.99E-04	Prohl (2003) [Benthic Fish], RBE=10	
Benthos		Pb-210	2.10E-06	Prohl (2003) [Bivalve Mollusc]
		Po-210	2.72E-04	Prohl (2003) [Bivalve Mollusc], RBE=10
	Ra-224	1.49E-03	Amiro (1997), RBE=10	
	Ra-226	1.58E-03	Prohl (2003) [Bivalve Mollusc], RBE=10	
	Ra-228	7.12E-06	Amiro (1997)	
	Th-228	1.66E-03	Prohl (2003) [Bivalve Mollusc], RBE=10	
	Th-230	2.37E-04	Prohl (2003) [Bivalve Mollusc], RBE=10	
	Th-232	2.01E-04	Prohl (2003) [Bivalve Mollusc], RBE=10	
	U-234	2.37E-04	Prohl (2003) [Bivalve Mollusc], RBE=10	
	U-235	2.28E-04	Prohl (2003) [Bivalve Mollusc], RBE=10	
	U-238	4.99E-04	Prohl (2003) [Bivalve Mollusc], RBE=10	

Final – Environmental Risk Assessment for the Cameco Port Hope Conversion Facility

Aquatic Receptors	Radio-nuclide	Internal DC (Gy/y per Bq/kgFW)	Reference Information
Horned Grebe	Pb-210	2.10E-06	Prohl (2003) [Bird] <sup>a</sup>
	Po-210	2.72E-05	Prohl (2003) [Bird] <sup>a</sup> , RBE=10
	Ra-224	1.49E-03	Amiro (1997), RBE=10
	Ra-226	1.58E-04	Prohl (2003) [Bird] <sup>a</sup> , RBE=10
	Ra-228	7.12E-06	Amiro (1997)
	Th-228	1.66E-04	Prohl (2003) [Bird] <sup>a</sup> , RBE=10
	Th-230	2.37E-05	Prohl (2003) [Bird] <sup>a</sup> , RBE=10
	Th-232	2.01E-05	Prohl (2003) [Bird] <sup>a</sup> , RBE=10
	U-234	2.37E-05	Prohl (2003) [Bird] <sup>a</sup> , RBE=10
	U-235	2.37E-05	Prohl (2003) [Bird] <sup>a</sup> , RBE=10
	U-238	4.99E-05	Prohl (2003) [Bird] <sup>a</sup> , RBE=10
Lesser Scaup	Pb-210	2.10E-06	Prohl (2003) [Bird] <sup>a</sup>
	Po-210	2.72E-05	Prohl (2003) [Bird] <sup>a</sup> , RBE=10
	Ra-224	1.49E-03	Amiro (1997), RBE=10
	Ra-226	1.58E-04	Prohl (2003) [Bird] <sup>a</sup> , RBE=10
	Ra-228	7.12E-06	Amiro (1997)
	Th-228	1.66E-04	Prohl (2003) [Bird] <sup>a</sup> , RBE=10
	Th-230	2.37E-05	Prohl (2003) [Bird] <sup>a</sup> , RBE=10
	Th-232	2.01E-05	Prohl (2003) [Bird] <sup>a</sup> , RBE=10
	U-234	2.37E-05	Prohl (2003) [Bird] <sup>a</sup> , RBE=10
	U-235	2.37E-05	Prohl (2003) [Bird] <sup>a</sup> , RBE=10
	U-238	4.99E-05	Prohl (2003) [Bird] <sup>a</sup> , RBE=10
Pelagic Fish	Pb-210	2.10E-06	Prohl (2003) [Pelagic Fish]
	Po-210	2.72E-04	Prohl (2003) [Pelagic Fish], RBE=10
	Ra-224	1.49E-03	Amiro (1997), RBE=10
	Ra-226	1.58E-03	Prohl (2003) [Pelagic Fish], RBE=10
	Ra-228	7.12E-06	Amiro (1997)
	Th-228	1.66E-03	Prohl (2003) [Pelagic Fish], RBE=10
	Th-230	2.37E-04	Prohl (2003) [Pelagic Fish], RBE=10
	Th-232	2.01E-04	Prohl (2003) [Pelagic Fish], RBE=10
	U-234	2.37E-04	Prohl (2003) [Pelagic Fish], RBE=10
U-235	2.28E-04	Prohl (2003) [Pelagic Fish], RBE=10	
	U-238	4.99E-04	Prohl (2003) [Pelagic Fish], RBE=10

Notes:

<sup>a</sup> External DC for aquatic bird, freshwater-estuarine ecosystem (Prohl 2003, Table 4-8).

Final – Environmental Risk Assessment for the Cameco Port Hope Conversion Facility

Table 6.23 EcoRA: Dose Coefficients – Aquatic Biota, External

Aquatic Receptors	Radio-nuclide	External (SW) (Gy/y per Bq/m <sup>3</sup> )	Reference	External (Sed) (Gy/y per Bq/kgDW)	Reference
Aquatic Vegetation	Pb-210	1.66E-09	Prohl (2003) [Vascular Plant]	Not Available  (See prior discussion)	
	Po-210	4.29E-14	Prohl (2003) [Vascular Plant]		
	Ra-224	7.76E-06	Prohl (2003) [Vascular Plant]		
	Ra-226	1.40E-08	Prohl (2003) [Vascular Plant]		
	Ra-228	4.73E-06	Prohl (2003) [Vascular Plant]		
	Th-228	1.14E-08	Prohl (2003) [Vascular Plant]		
	Th-230	2.01E-11	Prohl (2003) [Vascular Plant]		
	Th-232	1.49E-11	Prohl (2003) [Vascular Plant]		
	U-234	1.58E-11	Prohl (2003) [Vascular Plant]		
	U-235	1.14E-09	Prohl (2003) [Vascular Plant]		
	U-238	4.12E-09	Prohl (2003) [Vascular Plant]		
Benthic Fish	Pb-210	3.59E-11	Prohl (2003) [Benthic Fish]	3.32E-08	Amiro (1997)
	Po-210	3.85E-14	Prohl (2003) [Benthic Fish]	5.16E-11	Amiro (1997)
	Ra-224	7.76E-06	Prohl (2003) [Benthic Fish]	1.16E-05	Amiro (1997)
	Ra-226	7.88E-09	Prohl (2003) [Benthic Fish]	4.80E-08	Amiro (1997)
	Ra-228	4.73E-06	Prohl (2003) [Benthic Fish]	7.10E-06	Amiro (1997)
	Th-228	7.18E-09	Prohl (2003) [Benthic Fish]	2.25E-08	Amiro (1997)
	Th-230	3.33E-12	Prohl (2003) [Benthic Fish]	1.07E-08	Amiro (1997)
	Th-232	2.45E-12	Prohl (2003) [Benthic Fish]	9.33E-09	Amiro (1997)
	U-234	3.07E-12	Prohl (2003) [Benthic Fish]	1.21E-08	Amiro (1997)
	U-235	7.27E-10	Prohl (2003) [Benthic Fish]	9.95E-07	Amiro (1997)
	U-238	2.80E-10	Prohl (2003) [Benthic Fish]	9.48E-09	Amiro (1997)

Final – Environmental Risk Assessment for the Cameco Port Hope Conversion Facility

Aquatic Receptors	Radio-nuclide	External (SW) (Gy/y per Bq/m <sup>3</sup> )	Reference	External (Sed) (Gy/y per Bq/kgDW)	Reference
Benthos	Pb-210	6.48E-11	Prohl (2003) [Bivalve Mollusc]	3.32E-08	Amiro (1997)
	Po-210	4.12E-14	Prohl (2003) [Bivalve Mollusc]	5.16E-11	Amiro (1997)
	Ra-224	7.76E-06	Amiro (1997)	1.16E-05	Amiro (1997)
	Ra-226	8.58E-09	Prohl (2003) [Bivalve Mollusc]	4.80E-08	Amiro (1997)
	Ra-228	4.73E-06	Amiro (1997)	7.10E-06	Amiro (1997)
	Th-228	7.71E-09	Prohl (2003) [Bivalve Mollusc]	2.25E-08	Amiro (1997)
	Th-230	3.85E-12	Prohl (2003) [Bivalve Mollusc]	1.07E-08	Amiro (1997)
	Th-232	2.89E-12	Prohl (2003) [Bivalve Mollusc]	9.33E-09	Amiro (1997)
	U-234	3.59E-12	Prohl (2003) [Bivalve Mollusc]	1.21E-08	Amiro (1997)
	U-235	8.06E-10	Prohl (2003) [Bivalve Mollusc]	9.95E-07	Amiro (1997)
	U-238	4.64E-10	Prohl (2003) [Bivalve Mollusc]	9.48E-09	Amiro (1997)
	Horned Grebe	Pb-210	1.75E-08	Prohl (2003) [Bird] <sup>a</sup>	3.32E-08
Po-210		3.33E-11	Prohl (2003) [Bird] <sup>a</sup>	5.16E-11	Amiro (1997)
Ra-224		7.76E-06	Amiro (1997)	1.16E-05	Amiro (1997)
Ra-226		6.83E-06	Prohl (2003) [Bird] <sup>a</sup>	4.80E-08	Amiro (1997)
Ra-228		7.76E-06	Amiro (1997)	7.10E-06	Amiro (1997)
Th-228		6.31E-06	Prohl (2003) [Bird] <sup>a</sup>	2.25E-08	Amiro (1997)
Th-230		2.01E-09	Prohl (2003) [Bird] <sup>a</sup>	1.07E-08	Amiro (1997)
Th-232		1.40E-09	Prohl (2003) [Bird] <sup>a</sup>	9.33E-09	Amiro (1997)
U-234		1.66E-09	Prohl (2003) [Bird] <sup>a</sup>	1.21E-08	Amiro (1997)
U-235		5.87E-07	Prohl (2003) [Bird] <sup>a</sup>	9.95E-07	Amiro (1997)
U-238		1.66E-07	Prohl (2003) [Bird] <sup>a</sup>	9.48E-09	Amiro (1997)

Final – Environmental Risk Assessment for the Cameco Port Hope Conversion Facility

Aquatic Receptors	Radio-nuclide	External (SW) (Gy/y per Bq/m <sup>3</sup> )	Reference	External (Sed) (Gy/y per Bq/kgDW)	Reference
Lesser Scaup	Pb-210	1.75E-08	Prohl (2003) [Bird] <sup>a</sup>	3.32E-08	Amiro (1997)
	Po-210	3.33E-11	Prohl (2003) [Bird] <sup>a</sup>	5.16E-11	Amiro (1997)
	Ra-224	7.76E-06	Amiro (1997)	1.16E-05	Amiro (1997)
	Ra-226	6.83E-06	Prohl (2003) [Bird] <sup>a</sup>	4.80E-08	Amiro (1997)
	Ra-228	7.76E-06	Amiro (1997)	7.10E-06	Amiro (1997)
	Th-228	6.31E-06	Prohl (2003) [Bird] <sup>a</sup>	2.25E-08	Amiro (1997)
	Th-230	2.01E-09	Prohl (2003) [Bird] <sup>a</sup>	1.07E-08	Amiro (1997)
	Th-232	1.40E-09	Prohl (2003) [Bird] <sup>a</sup>	9.33E-09	Amiro (1997)
	U-234	1.66E-09	Prohl (2003) [Bird] <sup>a</sup>	1.21E-08	Amiro (1997)
	U-235	5.87E-07	Prohl (2003) [Bird] <sup>a</sup>	9.95E-07	Amiro (1997)
	U-238	1.66E-07	Prohl (2003) [Bird] <sup>a</sup>	9.48E-09	Amiro (1997)
	Pelagic Fish	Pb-210	5.34E-11	Prohl (2003) [Pelagic Fish]	Not Applicable  <i>(Exposure sediment dose pathway not applicable to pelagic fish due to location within the water column (depth). Assessed for benthic fish.)</i>
Po-210		4.03E-14	Prohl (2003) [Pelagic Fish]		
Ra-224		7.76E-06	Amiro (1997)		
Ra-226		8.41E-09	Prohl (2003) [Pelagic Fish]		
Ra-228		4.73E-06	Amiro (1997)		
Th-228		7.53E-09	Prohl (2003) [Pelagic Fish]		
Th-230		3.77E-12	Prohl (2003) [Pelagic Fish]		
Th-232		2.80E-12	Prohl (2003) [Pelagic Fish]		
U-234		3.42E-12	Prohl (2003) [Pelagic Fish]		
U-235		7.88E-10	Prohl (2003) [Pelagic Fish]		
U-238	3.85E-10	Prohl (2003) [Pelagic Fish]			

Notes:

<sup>a</sup> External DC for aquatic bird, freshwater-estuarine ecosystem (Prohl 2003, Table 4-8).

## 6.2.7 Transfer Factors

To estimate intake up the food chain, concentrations of COPCs in terrestrial vegetation, earthworms and small mammals (as prey) are estimated using transfer factors (TFs) from literature sources. The associated tissue concentrations in terrestrial vegetation, earthworms and small mammals from all exposure pathways are estimated from soil concentrations as shown in Equation 6-6:

$$C_{biota} = C_{soil} \times TF_{soil-to-biota} \quad (6-6)$$

Where:

$C_{biota}$  = COPC concentration in biota (vegetation, earthworms, small mammals) [mg/(kg ww)]

$C_{soil}$  = COPC concentration in soil [mg/(kg dw)]

TF = transfer factor from soil-to-biota [(mg/(kg ww))/(mg/(kg dw))]

Soil-to-small mammal transfer factors are not always available for all COPCs. As an alternative, mammalian tissue concentrations can also be estimated from allometrically scaled feed-to-tissue transfer factors as shown in Equation 6-7:

$$C_{tissue} = I_{total} \times TF_{feed-to-tissue} \quad (6-7)$$

Where:

$C_{tissue}$  = COPC concentration in tissue of ingested animal [mg/(kg ww)]

$I_{total}$  = intake of COPC by ingested animal from all pathways ( $\sum I_n$ ) [mg/d]

$TF_{feed-to-tissue}$  = allometrically scaled transfer factor from feed-to-tissue [d/kg]

Transfer factors from literature for feed-to-beef (cow) are available for many COPCs, which can then be allometrically scaled for the ingested animal using the ratio of their body weight to that of the cow using Equation 6-8:

$$TF_{sm} = TF_{fb} \times \left( \frac{BW_{sm}}{BW_{cow}} \right)^{-0.75} \quad (6-8)$$

Where:

$TF_{sm}$  = feed-to-tissue transfer factor for small mammal [d/(kg ww)]

$TF_{fb}$  = feed-to-tissue transfer factor for beef [d/(kg ww)]

$BW_{sm}$  = body weight of small mammal [kg]

$BW_{cow}$  = body weight of cow [kg]

Table 6.24 presents the transfer factors selected for the EcoRA. For terrestrial plants, a moisture content of 81% was used for converting between dry weight (DW) and wet weight (WW or FW).

Table 6.24 EcoRA: Transfer Factors

a) Aquatic Receptors

COPC	Sediment-Water Kd (L/kg)	Ref	Aquatic Vegetation-Water TF (L/kg FW)	Ref	Benthos-Water TF (L/kg FW)	Ref	Fish-Water TF (L/kg FW)	Ref	Feed-to-Bird TF (d/kg FW)	Ref
Aluminum	-	ND	-	ND	3400	5	51	6	-	ND
Ammonia	-	ND	-	ND	-	ND	-	ND	-	ND
Arsenic	10	1	0.75	2	120	4	390	6	1.2	9
Barium	2000		63	2	180	4	47	6	0.019	9
Chloride	20	1	50	2	140	4	95	6	1.75	9
Fluoride	-	ND	100	2	4	3	10	6	-	ND
Potassium	-	ND	-	ND	590	5	3200	6	-	ND
Polonium	150	1	2000	2	20,000	3	36	6	2.4	10
Radium	7400	1	0.0029	2	900	4	210	6	0.03	9
Strontium	190	1	410	2	240	4	190	6	0.02	9
Uranium	50	1	210	2	110	4	2.4	6	0.75	9
Thorium	190000	1	2200	2	110	4	190	6	0.01	9
Zinc	500	1	20000	2	1800	4	4700	6	0.47	9

References:

1. CSA N288.1 (2014), Table A.26
  2. CSA N288.1 (2014), Table A.25f, freshwater plants
  3. US DOE (2003)
  4. CSA N288.1 (2014), Table A.25e
  5. IAEA (2010), Table 56 (mean)
  6. IAEA (2010), Table 57
  7. CSA N288.1 (2014), Table A.25a
  8. NCRP (1996)
  9. CSA N288.1 (2014), Table G.3, value for poultry meat
  10. IAEA (2010) Table 34
- ND - No data available

Final – Environmental Risk Assessment for the Cameco Port Hope Conversion Facility

**b) Terrestrial Receptors**

COPC	Soil-Vegetation (kg/kgDW)	Ref	Feed-to-Bird (d/kgFW)	Ref	Feed-to-Mammal (d/kgFW)	Ref	Soil-to-Earthworm (g/gDW)	Ref
Aluminium	0.004	US EPA SLERA (1999a) App C Table C-2		ND		ND	0.22	US EPA SLERA (1999a) App C Table C-2
Ammonia		ND		ND		ND		ND
Antimony	0.0015	CSA (2014) Table G.3	0.1	CSA (2014) Table G.3, Poultry	0.0012	CSA (2014) Table G.3, Beef	1	ND. Assumed equal to soil.
Arsenic	0.25	CSA (2014) Table G.3	1.2	CSA (2014) Table G.3, Poultry	0.02	CSA (2014) Table G.3, Beef	0.258	Sample <i>et al.</i> 1998
Barium	0.028	CSA (2014) Table G.3	0.019	CSA (2014) Table G.3, Poultry	0.00014	CSA (2014) Table G.3, Beef	0.258	Eco-SSL Attachments 4-1
Boron	4	Baes <i>et al.</i> (1984)		ND	0.0008	NCRP (1996)	1	ND. Assumed equal to soil.
Bromide		NA		NA		NA	1	ND. Assumed equal to soil.
Cadmium	1.67	NCRP (1996)	1.7	IAEA (2010) Table 34	0.001	NCRP (1996)	17.1	Sample <i>et al.</i> 1998
Calcium		NA		NA		NA	1	ND. Assumed equal to soil.
Chloride	89	CSA (2014) Table G.3	1.75	CSA (2014) Table G.3, Poultry	0.017	CSA (2014) Table G.3, Beef	1	ND. Assumed equal to soil.
Cobalt	0.047	CSA (2014) Table G.3	0.97	CSA (2014) Table G.3, Poultry	0.00043	CSA (2014) Table G.3, Beef	0.122	Eco-SSL Attachments 4-1
Copper	0.8	IAEA (2010) Table 17	0.5	IAEA (1994)	0.022	IAEA (1994)	0.515	Eco-SSL Attachments 4-1
Fluoride	0.1	NCRP (1996)		ND	0.15	Baes <i>et al.</i> (1998)	1	ND. Assumed equal to soil.
Iron	0.005	CSA (2014) Table G.3	1.4	CSA (2014) Table G.3, Poultry	0.014	CSA (2014) Table G.3, Beef	0.038	Sample <i>et al.</i> 1998



Final – Environmental Risk Assessment for the Cameco Port Hope Conversion Facility

COPC	Soil-Vegetation (kg/kgDW)	Ref	Feed-to-Bird (d/kgFW)	Ref	Feed-to-Mammal (d/kgFW)	Ref	Soil-to-Earthworm (g/gDW)	Ref
Lead	0.31	IAEA (2010) Table 17	0.4	NCRP (1996)	0.0007	IAEA (2010) Table 30 (mean, beef)	3.34	Sample <i>et al.</i> 1998
Magnesium		ND		ND		ND	1	ND. Assumed equal to soil.
Manganese	0.35	CSA (2014) Table G.3	0.0019	CSA (2014) Table G.3, Poultry	0.0006	CSA (2014) Table G.3, Beef	1	ND. Assumed equal to soil.
Nickel	0.47	CSA (2014) Table G.3	0.31	CSA (2014) Table G.3, Poultry	0.005	CSA (2014) Table G.3, Beef	1.06	Eco-SSL Attachments 4-1
Nitrate		ND		ND		ND		NA
Nitrite		ND		ND		ND		NA
PCBs	0.01	US EPA (1998) (R6)	0.0319	US EPA (1998) (R6)	0.0404	US EPA (1998) (R6) (Beef)	8.909	Sample <i>et al.</i> (1998)
PHC F1		NA		NA		NA		NA
PHC F2		NA		NA		NA		NA
PHC F3		NA		NA		NA		NA
PHC F4		NA		NA		NA		NA
Polonium	0.003	Baes <i>et al.</i> (1984)	2.4	IAEA (2010) Table 34	0.005	US DOE (2003)	ND	ND
Phosphate		NA		ND		NA		NA
Potassium	1.3	IAEA 2010 Table 17		ND		ND		ND
Radium	0.11	CSA (2014) Table G.3	0.03	CSA (2014) Table G.3, Poultry	0.0017	CSA (2014) Table G.3, Beef	ND	ND
Selenium	0.45	CSA (2014) Table G.3	9.7	CSA (2014) Table G.3, Poultry	0.1	CSA (2014) Table G.3, Beef	0.88	Eco-SSL Attachments 4-1
Silver		NA		NA		NA	1	ND. Assumed equal to soil.
Sodium		NA		NA		NA	1	ND. Assumed equal to soil.
Strontium	0.87	CSA (2014)	0.02	CSA (2014)	0.0013	CSA (2014)	0.117	Sample <i>et al.</i> 1998

Final – Environmental Risk Assessment for the Cameco Port Hope Conversion Facility

COPC	Soil-Vegetation (kg/kgDW)	Ref	Feed-to-Bird (d/kgFW)	Ref	Feed-to-Mammal (d/kgFW)	Ref	Soil-to-Earthworm (g/gDW)	Ref
		Table G.3		Table G.3, Poultry		Table G.3, Beef		
Sulphate	ND			ND		ND	1	ND. Assumed equal to soil.
Total Dissolved Solids	ND			ND		ND	1	ND. Assumed equal to soil.
Thorium	0.003	CSA (2014) Table G.3	0.01	CSA (2014) Table G.3, Poultry	0.00023	CSA (2014) Table G.3, Beef	ND	ND
Uranium	0.01	CSA (2014) Table G.3	0.75	CSA (2014) Table G.3, Poultry	0.00039	CSA (2014) Table G.3, Beef	0.033	Sample <i>et al.</i> 1998
Vanadium	0.1	NCRP (1996)		ND	0.025	Baes <i>et al.</i> (1984)	0.042	Eco-SSL Attachments 4-1
Zinc	1.3	CSA (2014) Table G.3	0.47	CSA (2014) Table G.3, Poultry	0.16	CSA (2014) Table G.3, Beef	5.77	Sample <i>et al.</i> 1998

Notes:

NA – Not Applicable – Does not travel up food chain.

ND – No Data.

## 6.2.8 External Gamma

In addition to the doses from individual radionuclide measurements, doses to biota from gamma radiation are also estimated in this EcoRA. Measured fence-line gamma levels were applied to all surface-dwelling VECs (i.e., those residing above-ground or above the water surface). The fence-line gamma measurements (based on monthly measurements from Cameco) represent total dose, including background. The measured gamma levels, reported in  $\mu\text{R}/\text{h}$  were converted to  $\text{mGy}/\text{d}$  assuming 100% residence time.

In Tier 1, the maximum measured gamma (i.e., location of highest gamma reading in 2014) was  $0.0081 \text{ mGy}/\text{d}$ . This value was applied to receptors at all locations (a very conservative estimate). As seen in section 6.4 below (Risk Results), the measured fence-line gamma is not a large contributor to dose.

## 6.3 Effects Assessment

### 6.3.1 Non-Radiological Benchmark Values

Overall, ecological toxicity benchmark values for non-radiological COPCs were obtained based on the following hierarchies of sources. More detailed description of the methodologies used in selecting these toxicity benchmark values is presented in subsequent subsections. The hierarchies also consider CSA N288.6 guidance (CSA 2012), but chooses recent, credible sources preferentially (some CSA 2012 references are considered outdated).

#### Terrestrial Vegetation & Invertebrates:

1. MOE (2011) values protective of soil invertebrates and plants, based on industrial land use;
2. CCME supporting documents for Canadian Soil Quality Guidelines;
3. US EPA Ecological Soil Screening Levels (Eco-SSLs); and
4. Environment Canada (2013) Database of Guidelines.

#### Terrestrial Mammals & Birds:

1. MOE (2011);
2. US EPA Eco-SSLs; and,
3. Sample *et al.* (1996).

#### Aquatic Birds:

1. Suter & Tsao (1996).
2. US EPA ECOTOX Database;
3. MOE (2011); and,

4. US EPA Eco-SSLs.

*Fish, Aquatic Vegetation and Aquatic Invertebrates:*

1. US EPA ECOTOX Database;
2. Suter & Tsao (1996); and,
3. CCME (2009, 2011, 2015).

### 6.3.1.1 Terrestrial Invertebrates and Vegetation

In selecting the TRVs for terrestrial vegetation and invertebrates (earthworms), a review was conducted of the MOE (2011) rationale document, the soil quality standards of the CCME, the Eco-SSL documents of the U.S. EPA, along with values from the Environment Canada (2013) Database of Guidelines. The selected values are shown in Table 6.25, and compared against those used in previous PHCF risk assessment studies.

The MOE considers ecotoxicity criteria in the development of soil criteria, so that soil standards are protective of both human and ecological health. In the MOE update of their soil criteria (2011), plant and soil invertebrate protection values for agricultural/residential/parkland and industrial/commercial land use were developed following the CCME (1996) protocol using current scientific literature data on toxicity to agricultural crops, native plant species and soil dwelling organisms. It is commonly acknowledged that the level of protection for plants and soil organisms can be less stringent for commercial/industrial land use than for agricultural/residential/parkland land use. However, in following the CCME (1996) protocol, this was problematic for no/lowest observable effects concentration (NOEC/LOEC) data (a combined NOEC/LOEC dataset was used for the agricultural/residential/parkland derivation, while an LOEC-only dataset was used for the commercial/industrial derivation which can throw out useful information and thereby drive the value down). To solve this issue, the MOE used a combined NOEC/LOEC dataset for both land uses, and selected the 25<sup>th</sup> and 50<sup>th</sup> percentile values as the agricultural/residential/parkland and industrial/commercial protection values, respectively. In situations where a value for plant and soil organism protection could not be developed for industrial/commercial land use, the MOE applied a factor of 2 to the agricultural/residential/parkland value. This was felt to be sufficiently protective for an industrial/commercial setting. It was determined that the above-described MOE approach was appropriate for use in the current assessment and thus, the MOE values for protection of plants and soil invertebrates were selected as the TRVs when available.

Following the above methodology, the MOE was able to develop components values for 20 constituents. The MOE also reviewed information from other jurisdictions and found that CCME ecological protection numbers and the numbers developed by the Netherlands would provide a suitable level of protection for Ontario. The Netherlands criteria were derived using the 50<sup>th</sup> percentile of the “No Observed Effect Distribution” (NOEC) of the data.

If no data were available from MOE, then a review of the available information was undertaken and an appropriate value selected.

Final – Environmental Risk Assessment for the Cameco Port Hope Conversion Facility

Table 6.25 EcoRA TRVs: Terrestrial Plants & Earthworms (mg/kg)

COPCs	SWRA		SWRA		Fenceline RA		Current Study			
	June 2009 <sup>a</sup>		Addendum		2013 <sup>c</sup>		2014			
			December 2009 <sup>b</sup>				Earthworm		Plants	
	Earthworm	Plants	Earthworm	Plants	Earthworm	Plants	Industrial/ Commercial/ Community	Residential/ Parkland/ Institutional	Industrial/ Commercial/ Community	Residential/ Parkland/ Institutional
Aluminium	NA	NA	NA	NA	NA	NA	50 <sup>g</sup>	50 <sup>g</sup>	50 <sup>g</sup>	50 <sup>g</sup>
Ammonia	NA	NA	NA	NA	NA	NA	NA	NA	NA	NA
Arsenic	22	22	34	34	20	22	34 <sup>c</sup>	20 <sup>d</sup>	34 <sup>c</sup>	20 <sup>d</sup>
Barium	330	1,500	330	1,500	750	750	1,500 <sup>c</sup>	750 <sup>d</sup>	1,500 <sup>c</sup>	750 <sup>d</sup>
Boron (Hot Water Soluble)	NA	NA	NA	NA	NA	NA	2 <sup>c</sup>	1.5 <sup>d</sup>	2 <sup>c</sup>	1.5 <sup>d</sup>
Boron (Total)	20	2	20	2	NA	NA	NA	NA	NA	NA
Bromide	NA	NA	NA	NA	NA	NA	NA	NA	300 <sup>e</sup>	50 <sup>e</sup>
Cadmium	NA	NA	NA	NA	10	12	24 <sup>c</sup>	12 <sup>d</sup>	24 <sup>c</sup>	12 <sup>d</sup>
Chloride	NA	NA	NA	NA	NA	NA	2500 <sup>g</sup>	350 <sup>g</sup>	2500 <sup>g</sup>	350 <sup>g</sup>
Cobalt	33	33	72	72	40	40	72 <sup>c</sup>	33 <sup>d</sup>	72 <sup>c</sup>	33 <sup>d</sup>
Copper	141	141	232	232	141	141	230 <sup>c</sup>	140 <sup>d</sup>	230 <sup>c</sup>	140 <sup>d</sup>
Fluoride	750	200	750	200	750	200	2000 <sup>e</sup>	400 <sup>e</sup>	2000 <sup>e</sup>	400 <sup>e</sup>
Iron	200	NA	200	NA	200	NA	200 <sup>g</sup>	200 <sup>g</sup>	NA	NA
Lead	246	246	1,100	1100	246	246	1,100 <sup>c</sup>	250 <sup>d</sup>	1,100 <sup>c</sup>	250 <sup>d</sup>
Magnesium	NA	NA	NA	NA	NA	NA	NA	NA	NA	NA
Manganese	NA	NA	NA	NA	NA	NA	450 <sup>f</sup>	450 <sup>f</sup>	220 <sup>f</sup>	220 <sup>f</sup>
Nickel	100	100	270	270	100	100	270 <sup>c</sup>	100 <sup>d</sup>	270 <sup>c</sup>	100 <sup>d</sup>
Nitrate	NA	NA	NA	NA	NA	NA	NA	NA	NA	NA
Nitrite	NA	NA	NA	NA	NA	NA	NA	NA	NA	NA
PHC F1	170	330	320	320	NA	NA	320 <sup>c</sup>	210 <sup>d</sup>	320 <sup>c</sup>	210 <sup>d</sup>
PHC F2	300	760	260	260	NA	NA	260 <sup>c</sup>	150 <sup>d</sup>	260 <sup>c</sup>	150 <sup>d</sup>
PHC F3	620	1700	1700	1700	NA	NA	1,700 <sup>c</sup>	300 <sup>d</sup>	1,700 <sup>c</sup>	300 <sup>d</sup>

Final – Environmental Risk Assessment for the Cameco Port Hope Conversion Facility

COPCs	SWRA		SWRA		Fenceline RA		Current Study			
	June 2009 <sup>a</sup>		Addendum		2013 <sup>c</sup>		2014			
			December 2009 <sup>b</sup>				Earthworm		Plants	
	Earthworm	Plants	Earthworm	Plants	Earthworm	Plants	Industrial/ Commercial/ Community	Residential/ Parkland/ Institutional	Industrial/ Commercial/ Community	Residential/ Parkland/ Institutional
PHC F4	NA	NA	NA	NA	NA	NA	3300 <sup>c</sup>	2800 <sup>d</sup>	3300 <sup>c</sup>	2800 <sup>d</sup>
Phosphate	NA	NA	NA	NA	NA	NA	NA	NA	NA	NA
Potassium	NA	NA	NA	NA	NA	NA	17 <sup>g</sup>	17 <sup>g</sup>	17 <sup>g</sup>	17 <sup>g</sup>
Selenium	4.1	10	2.9	2.9	10	10	10 <sup>c</sup>	10 <sup>d</sup>	10 <sup>c</sup>	10 <sup>d</sup>
Silver	NA	NA	NA	NA	NA	NA	40 <sup>c</sup>	NA	NA	NA
Sodium	NA	NA	NA	NA	NA	NA	1000 <sup>g</sup>	NA	NA	NA
Strontium	NA	NA	NA	NA	NA	NA	NA	NA	NA	NA
Sulphate	NA	NA	NA	NA	NA	NA	NA	NA	NA	NA
Total Dissolved Solids	NA	NA	NA	NA	NA	NA	NA	NA	NA	NA
Uranium	838	838	2,000	2000	500	500	2,000 <sup>c</sup>	500 <sup>d</sup>	2,000 <sup>c</sup>	500 <sup>d</sup>
Vanadium	NA	NA	NA	NA	200	200	200 <sup>c</sup>	200 <sup>d</sup>	200 <sup>c</sup>	200 <sup>d</sup>
Zinc	400	400	600	600	400	400	600 <sup>c</sup>	400 <sup>d</sup>	600 <sup>c</sup>	400 <sup>d</sup>
PCBs	NA	NA	NA	NA	NA	NA	33 <sup>c</sup>	33 <sup>d</sup>	33 <sup>c</sup>	33 <sup>d</sup>

Notes:

<sup>a</sup> Primarily MOE (2008) values for residential land use. See SENES (2009a) for more information.

<sup>b</sup> Primarily MOE (2008) values for industrial land use. See SENES (2009b) for more information.

<sup>c</sup> Primarily MOE (2011) values for industrial land use. See SENES (2013d) for more information.

<sup>d</sup> Primarily MOE (2011) values for residential land use.

<sup>e</sup> CCME supporting documents for Canadian Soil Quality.

<sup>f</sup> US EPA Ecological Soil Screening Levels (Eco-SSLs).

<sup>g</sup> Environment Canada (2013) Database of Guidelines.

NA – analyte is not applicable (i.e., not identified as a COPC) in the indicated study.

### 6.3.1.2 Terrestrial Mammals and Terrestrial Birds

In selecting the TRVs for terrestrial mammals and birds, values were primarily obtained from the US EPA risk-based ecological soil screening levels (Eco-SSLs), and from Sample *et al.* (1996). Data from MOE (2011) were then used to fill any remaining data gaps.

Dose-based TRVs for wildlife were chosen from a review of data presented in the documentation of U.S. EPA Eco-SSLs for most analytes, and literature studies were reviewed for chronic dose values for analytes without Eco-SSL data. Endpoints involving growth and reproduction were considered to be relevant to assessment of wildlife populations. TRV were derived preferentially from LOAEL data. The use of LOAELs is consistent with CSA (2012), which states that selected benchmarks should correspond to the lowest exposure levels (e.g., LOAELs) associated with adverse effects. A comparison was made to mortality based endpoints to ensure that the derived TRV does not exceed a mortality endpoint. Where available, the LOAELs were paired with NOAELs for reference purposes.

In general, if three or more LOAEL data were available for a test species, then the geometric mean of the LOAEL data was calculated and used as the TRV for the given test species (assuming other conditions (above) were met). Otherwise, the lowest bounded LOAEL value was used as the TRV in this study.

An important aspect in TRV selection and derivation is the avoidance of allometric scaling. Historically, the results of toxicity tests on laboratory animals which were typically limited to test species, were adjusted for other species by applying allometric equations for weight differences between test species and species of interest in the assessment. More recently, the allometric weight adjustment was found to be inappropriate for most analytes and ecological receptors. Therefore, the approach is instead to find toxicity data for species that most closely represent a given ecological receptor in a particular assessment (i.e., use of surrogates).

In the present risk assessment, when obtaining TRV values, it is desirable to select values based on test species that closely match the ecological receptor in terms of diet and overall organism size. However, the availability of toxicity data varies and at times a close match is not available. In general, the following process was used to select TRVs:

#### For Mammalian Receptors:

- **Red Fox:** TRVs based on tests using dogs were preferentially selected, as these TRVs offer the closest species match in terms of diet and organism size. In cases where a matching TRV was not available, the lowest overall mammalian TRV was selected.
- **Rabbit:** TRVs based on tests using rabbits were preferentially selected, as these TRVs offer the closest species match in terms of diet and organism size. In cases where such TRVs are not available, the TRV for a mouse was chosen as the next closest match based on shared herbivorous diet. If not available, the lowest overall mammalian TRV was selected.
- **Meadow Vole:** TRVs based on meadow voles were preferentially selected, as these are the closest species match in terms of diet and organism size. In cases where such TRVs are not available, the TRV for a mouse was chosen as the next closest match based on size and shared herbivorous diet. If not available, the lowest overall mammalian TRV was selected.

For Terrestrial Avian Receptors:

- **American Robin:** TRVs based on small, terrestrial, omnivorous test subjects are preferred, as these TRVs offer the closest species match in terms of diet and organism size. Often though, toxicity data are limited to test subjects such as chickens, quails, and ducks, in which cases data for quails were selected. In cases where such TRVs were not available, then the lowest terrestrial avian TRV was used.
- **Yellow Warbler:** TRVs based on small, terrestrial, insectivorous test subjects are preferred, as these TRVs offer the closest species match in terms of diet and organism size. Often though, toxicity data are limited to test subjects such as chickens, quails, and ducks, in which cases the lowest avian TRV among terrestrial test subject species was used.
- **Great Horned Owl:** TRVs based on large, terrestrial, carnivorous test subjects are preferred, as these TRVs offer the closest species match in terms of diet and organism size. Often though, toxicity data are limited to test subjects such as chickens, quails, and ducks, in which cases the lowest avian TRV among terrestrial test subject species was used.

Table 6.26 presents the selected values for mammals.

Table 6.27 presents the selected values for birds.

Table 6.26 EcoRA TRVs for Terrestrial Mammals (mg/kg/d)

COPCs	Test Species	LOAEL Data	Final TRV	Ecological Receptor	Comments
Al	Not Available				
Ammonia (Total)	Not Available				
As	Dog	3.05	3.05	Red Fox	US EPA Eco-SSL for Arsenic (US EPA 2005a).
	Mouse	20.7*	20.7*	Meadow Vole	
	Rabbit	3	3	Cotton-Tail Rabbit	
B (total)	Rat	94 <sup>b</sup>	94 <sup>b</sup>	Red Fox	See MOE (2011). Single study available, selected by default.
				Meadow Vole	
				Cotton-Tail Rabbit	
Ba	Rat	**	20	Red Fox	See MOE (2011). Single study available, selected by default.
				Meadow Vole	
				Cotton-Tail Rabbit	
Cd	Rat	0.91	0.91	Red Fox	US EPA Eco-SSL for Cadmium (US EPA 2005b)  Lowest LOAEL chosen as conservative default TRV.



Final – Environmental Risk Assessment for the Cameco Port Hope Conversion Facility

COPCs	Test Species	LOAEL Data	Final TRV	Ecological Receptor	Comments
	Mouse	9.56*	9.56*	Meadow Vole	US EPA Eco-SSL for Cadmium (US EPA 2005b)
	Mouse	9.56*	9.56*	Cotton-Tail Rabbit	
Co	Rat	13.4*	13.4*	Red Fox	US EPA Eco-SSL for Cobalt (US EPA 2005c) <i>Lowest LOAEL chosen as conservative default TRV.</i>
	Mouse	27.9*	27.9*	Meadow Vole	US EPA Eco-SSL for Cobalt (US EPA 2005c)
	Mouse	27.9*	27.9*	Cotton-Tail Rabbit	
Cu	Pig	8.8*	8.8*	Red Fox	US EPA Eco-SSL for Copper (US EPA 2007a) <i>No similar species, therefore, conservative default TRV selected: lowest species LOAEL that is above the lowest NOAEL.</i>
	Mouse	296*	296*	Meadow Vole	US EPA Eco-SSL for Copper (US EPA 2007a)
	Rabbit	45.7	45.7	Cotton-Tail Rabbit	
F	Mink	NA	31.4	Red Fox	Sample <i>et al.</i> (1996).
				Meadow Vole	<i>Based on a single study NOAEL (LOAEL not available).</i>
				Cotton-Tail Rabbit	
Fe	Not Available				
Mn	Rat	39.4*	39.4*	Red Fox	US EPA Eco-SSL for Manganese (US EPA 2007b) <i>No similar species, therefore, conservative default TRV selected: lowest species LOAEL.</i>
				Meadow Vole	
				Cotton-Tail Rabbit	
Ni	Dog	112	112	Red Fox	US EPA Eco-SSL for Nickel (US EPA 2007c)
	Meadow Vole	309	309	Meadow Vole	
	Mouse	33.2*	33.2*	Cotton-Tail Rabbit	
Pb	Mouse	14.1*	14.1*	Red Fox	US EPA Eco-SSL for Lead (US EPA 2005d) <i>Lowest LOAEL chosen as conservative default TRV.</i>
	Mouse	14.1	14.1	Meadow Vole	US EPA Eco-SSL for Lead (US EPA 2005d)
	Rabbit	50.4	50.4	Cotton-Tail Rabbit	
Sb	Mouse	**	1.25 <sup>b</sup>	Red Fox	See MOE (2011). Single study available, selected by default.
				Meadow Vole	
				Cotton-Tail Rabbit	
Se	Dog	0.21	0.21	Red Fox	US EPA Eco-SSL for Selenium (US EPA 2007d)
	Mouse	1.53*	1.53*	Meadow Vole	

Final – Environmental Risk Assessment for the Cameco Port Hope Conversion Facility

COPCs	Test Species	LOAEL Data	Final TRV	Ecological Receptor	Comments
	Mouse	1.53*	1.53*	Cotton-Tail Rabbit	
Sr	Rat	NA	263	Red Fox	Sample <i>et al.</i> (1996)
				Meadow Vole	Based on a single study NOAEL (LOAEL not available).
				Cotton-Tail Rabbit	
U	Mouse	NA	5.6	Red Fox	Sample <i>et al.</i> (1996)
				Meadow Vole	Based on a single study NOAEL (LOAEL not available), with correction for unit conversion error in Sample <i>et al.</i> (1996).
				Cotton-Tail Rabbit	
Zn	Sheep	34.9	34.9	Red Fox	US EPA Eco-SSL for Zinc (US EPA 2007e) <i>No similar species, therefore, conservative default TRV selected: lowest species LOAEL.</i>
	Mouse	4,395*	4,395*	Meadow Vole	US EPA Eco-SSL for Zinc (US EPA 2007e)
	Mouse	4,395*	4,395*	Cotton-Tail Rabbit	
PHC F2	Not Available				
PHC F3					

Notes:

\* Geometric mean of available data. Data for this test species are of sufficient quantity and quality to allow for calculation and use of a geometric mean.

\*\* See MOE (2011).

Table 6.27 EcoRA TRVs for Terrestrial Birds (mg/kg/d)

COPCs	Test Species	LOAEL Data	Final TRV	Ecological Receptor	Comments
Al	Not Available				
Ammonia (Total)	Not Available				
As	Chicken	3.6*	3.6*	American Robin	US EPA Eco-SSL for Arsenic (US EPA 2005a)  <i>Lowest LOAEL (geometric mean) among available terrestrial avian species chosen as a conservative default TRV.</i>
				Yellow Warbler	
				Great Horned Owl	
B (total)	Mallard Duck	NA	100 <sup>b</sup>	American Robin	MOE (2011); single study available, selected by default.
				Yellow Warbler	
				Great Horned Owl	
Ba	Chicken	NA	42 <sup>b</sup>	American Robin	MOE (2011); single study available, selected by default.
				Yellow Warbler	
				Great Horned Owl	
Cd	Quail	11.3*	11.3*	American Robin	US EPA Eco-SSL for Cadmium (US EPA 2005b)
	Chicken	4.38*	4.38*	Yellow Warbler	US EPA Eco-SSL for Cadmium (US EPA 2005b)
	Chicken	4.38*	4.38*	Great Horned Owl	<i>Lowest LOAEL (geometric mean) among available terrestrial avian species chosen as a conservative default TRV.</i>
Co	Chicken	14.1*	14.1*	American Robin	US EPA Eco-SSL for Cobalt (US EPA 2005c).  <i>Lowest LOAEL (geometric mean) among available terrestrial avian species chosen as a conservative default TRV.</i>
				Yellow Warbler	
				Great Horned Owl	
Cu	Turkey	27*	27*	American Robin	US EPA Eco-SSL for Copper (US EPA 2005d).  <i>Lowest LOAEL (geometric mean) among available terrestrial avian species chosen as a conservative default TRV</i>
				Yellow Warbler	
				Great Horned Owl	

Final – Environmental Risk Assessment for the Cameco Port Hope Conversion Facility

COPCs	Test Species	LOAEL Data	Final TRV	Ecological Receptor	Comments
F	Screech Owl	NA	7.8	American Robin	Sample <i>et al.</i> (1996)  Based on a single study NOAEL (LOAEL not available).
				Yellow Warbler	
				Great Horned Owl	
Fe	Not Available				
Mn	Turkey	356*	356*	American Robin	US EPA Eco-SSL for Manganese (US EPA 2007a).  Lowest LOAEL (geometric mean) among available terrestrial avian species chosen as a conservative default TRV.
				Yellow Warbler	
				Great Horned Owl	
Ni	Chicken	19.9*	19.9*	American Robin	US EPA Eco-SSL for Nickel (US EPA 2007b).  Lowest LOAEL (geometric mean) among available terrestrial avian species chosen as a conservative default TRV.
				Yellow Warbler	
				Great Horned Owl	
Pb	Quail	27.7*	27.7*	American Robin	US EPA Eco-SSL for Lead (US EPA 2005e).
	Dove	11.8*	11.8*	Yellow Warbler	US EPA Eco-SSL for Lead (US EPA 2005e).  Lowest LOAEL (geometric mean) among available terrestrial avian species chosen as a conservative default TRV.
	Dove	11.8*	11.8*	Great Horned Owl	
Sb	Not Available				
Se	Quail	0.75*	0.75*	American Robin	US EPA Eco-SSL for Selenium (US EPA 2007c)
	Chicken	0.59*	0.59*	Yellow Warbler	US EPA Eco-SSL for Selenium (US EPA 2007c).  Lowest LOAEL (geometric mean) among available terrestrial avian species chosen as a conservative default TRV.
	Owl	4.49	4.49	Great Horned Owl	US EPA Eco-SSL for Selenium (US EPA 2007c)
Sr	Mouse	263	263	American Robin	Sample <i>et al.</i> (1996)  Default value, based on a single study LOAEL using mice.
				Yellow Warbler	

Final – Environmental Risk Assessment for the Cameco Port Hope Conversion Facility

COPCs	Test Species	LOAEL Data	Final TRV	Ecological Receptor	Comments
				Great Horned Owl	
U	Black Duck	NA	16	American Robin	Sample <i>et al.</i> (1996)  <i>Based on a single study NOAEL (LOAEL not available).</i>
				Yellow Warbler	
				Great Horned Owl	
Zn	Quail	123*	123*	American Robin	US EPA Eco-SSL for Zinc (US EPA 2007d)
	Quail	123*	123*	Yellow Warbler	US EPA Eco-SSL for Zinc (US EPA 2007d).
	Quail	123*	123*	Great Horned Owl	<i>Lowest LOAEL (geometric mean) among available terrestrial avian species chosen as a conservative default TRV.</i>
PHC F2	Not Available				
PHC F3					

Notes:

\* Geometric mean of available data. Data for this test species are of sufficient quantity and quality to allow for calculation and use of a geometric mean.

\*\* See MOE (2011).

### Ammonia

Ammonia rapidly oxidizes to nitrate and is therefore rarely present in high concentrations naturally. Therefore, ammonia is not evaluated for food chain transfer.

### Iron

Iron is considered an essential nutrient. It is a necessary component for the protein molecules hemoglobin and myoglobin. It also plays an important role in oxygen delivery to tissues (NRC 2005). The National Research Council (NRC 2005) state that there are inadequate data available to accurately define maximum tolerable levels of iron from dietary or water sources for most non-laboratory animals. Very few studies have included incremental dose levels sufficient to determine thresholds for toxicity. However, maximum tolerable levels of iron have been determined for cattle, sheep, poultry (500 mg/kg) and swine (3000 mg/kg). Other reported levels of iron toxic to cattle are greater than 4000 ppm and 390 ppm for horses (Puls 1994). Iron toxicosis can occur in domesticated animals as they are often given dietary supplements. It is expected that most animals do not uptake large amounts of iron in their diet (NRC 2005) and it is not anticipated that iron will have the potential to cause adverse effects to terrestrial biotic receptors.

### PHC (Petroleum Hydrocarbons)

Food web transfer was not estimated for PHCs. In the development of the PHC soil quality guidelines, CCME (2008) stated that most PHCs are readily metabolized by vertebrates, modified into a more readily extractable form and thus do not tend to accumulate in tissues. In addition, PHCs are not readily absorbed into and accumulated into plant tissues. Based on this information, the impact on terrestrial animals does not need to be assessed.

#### 6.3.1.3 Aquatic Birds

The selection of TRVs for aquatic birds uses the same hierarchy of references as is used for terrestrial birds (Section 1.1.1.1 above), where values are primarily obtained from US EPA Eco-SSLs, Sample *et al.* (1996) and MOE (2011) used to fill any remaining data gaps.

A notable exception exists for aquatic birds (i.e., Horned Grebe and Lesser Scaup) compared to terrestrial birds in the toxicity data selection and TRV derivation process. For these aquatic birds, the general process relies preferentially on bounded-NOAEL data, not LOAEL data, and endpoints of mortality and reproduction are not included. This is because the Horned Grebe and Lesser Scaup are representative of select SARA species (see Section 6.1.1.2), and as such, an additional level of protection is warranted. Where available, the use of bounded-NOAEL data as opposed to LOAEL data – which are typically higher, and are used to determine potential effects – provides this additional level of conservatism and protection.

Table 6.28 presents the selected values for aquatic birds.

Table 6.28 EcoRA TRVs for Aquatic Birds (mg/kg/d)

COPCs	Final TRV	Ecological Receptor	Comments
Aluminum	No Data Available		
Ammonia	81.9	Horned Grebe	<p>No toxicity information available from the US EPA Eco-SSLs, or from Sample <i>et al.</i> (1996). A limited amount of chronic LOAEL and NOAEL data for growth, mortality, and reproduction endpoints has been identified among 3 available studies; Adams <i>et al.</i> (1975); Harter and Baker (1978); Leach <i>et al.</i> (1960) and Sasse and Baker (1974).</p> <p>As the aquatic bird receptor encompasses species at risk, NOAEL data for a growth endpoint are preferred (see prior discussion); however, NOAEL data exist only for mortality and reproduction endpoints, which are not desirable endpoints for species at risk. Recognizing the limited toxicity data available, the lowest value among all LOAEL and NOAEL data from the 3 studies mentioned above was used, resulting in a final TRV value of 81.9 mg/kg/d (LOAEL) for growth, which is lower than the reproduction/mortality NOAELs available and is sufficiently conservative.</p> <p>Further qualitative discussion on ammonia is also presented in Section 6.3.1.2.</p>
		Lesser Scaup	
As	1.5	Horned Grebe	<p>US EPA Eco-SSL for Arsenic (US EPA 2005a)</p> <p>Data are limited to only 5 studies, producing only 3 LOAEL values once these data were assessed as outlined in Section 6.3.1.2 (e.g. using only LOAELs and paired LOAEL-NOAELs, etc.). Since the aquatic bird receptor encompasses species at risk, NOAEL data for a growth endpoint are preferred (see prior discussion). However, only a single NOAEL value exists, and it is un-paired and is greater than the lowest LOAEL value for growth. So, recognizing the limited toxicity data available, the lowest LOAEL value was instead used, resulting in a final TRV value of 1.5 mg/kg/d (LOAEL) which is lower than the only available NOAEL (2.24 mg/kg/d) and is sufficiently conservative.</p>
		Lesser Scaup	
Ba	No Data	Horned Grebe Lesser Scaup	No toxicity information available from Eco-SSL or Sample <i>et al.</i> (1996) for avian species. Given the lack of toxicity data for avian wildlife, and the large uncertainty inherent in using a mammalian surrogate, a TRV has not been selected.
Cd	3.08	Horned Grebe	<p>US EPA Eco-SSL for Cadmium (US EPA 2005b)</p> <p>Since the aquatic bird receptor encompasses species at risk, NOAEL data for a growth endpoint are preferred (see prior discussion). The geometric mean NOAEL for mallard test species was selected.</p>
		Lesser Scaup	
Cl-	163	Horned Grebe	<p>NOAEL, from Krista <i>et al.</i> (1961)</p> <p>Since the aquatic bird receptor encompasses species at risk, NOAEL data for a growth endpoint are preferred (see prior discussion). A single NOAEL value for mallard test species is available. Given the limit amount of toxicity data, this value was selected by default.</p>
		Lesser Scaup	
F	7.8	Horned Grebe	<p>Sample <i>et al.</i> (1996)</p> <p>Based on a single study NOAEL (LOAEL not available).</p>
		Lesser Scaup	
K	No Data Available		

Final – Environmental Risk Assessment for the Cameco Port Hope Conversion Facility

COPCs	Final TRV	Ecological Receptor	Comments
Sr	No Data	Horned Grebe	No toxicity information available from Eco-SSL or Sample <i>et al.</i> (1996); therefore no confident avian TRV is available. The Sample <i>et al.</i> (1996) mammalian TRV (LOAEL) of 263 mg/kg/day based on toxicity to mice has been used as a surrogate in some risk assessments to derive a potential avian TRV, however, there is considerable uncertainty in this application and it does not produce a confident TRV. As such, the lack of toxicity is acknowledged, and a TRV is not derived here..
		Lesser Scaup	
U	16	Horned Grebe	Sample <i>et al.</i> (1996) <i>Based on a single study NOAEL (LOAEL not available).</i>
		Lesser Scaup	
Zn	62.7	Horned Grebe	US EPA Eco-SSL for Zinc (US EPA 2007d) Since the aquatic bird receptor encompasses species at risk, NOAEL data for a growth endpoint are preferred (see prior discussion). For duck test subjects, no growth NOAELs are available, whereas only a single growth LOAEL is available (126 mg/kg/d). A single reproduction LOAEL is also available (31.2 mg/kg/d), for perspective. Geometric mean of these 2 LOAEL values is 62.7 mg/kg/d. For chicken test subjects, 18 bounded-NOAELs are available (geomean of 105 mg/kg/d), with 35 LOAELs (18 bounded) (geomean of 185 mg/kg/d).
		Lesser Scaup	Given this information, the derived geometric mean TRV of 62.7 mg/kg/d for mallards was chosen, as it offers a lower (more protective; more conservative) value than those derived for chickens and matches the aquatic bird receptors well (since the test species is also an aquatic bird), despite the fact that it is derived using LOAEL data including the reproduction endpoint.



#### 6.3.1.4 Aquatic Biota (Fish, Vegetation, and Invertebrates)

In selecting the TRVs for aquatic biota, toxicity data were primarily obtained from the US EPA ECOTOX database, and water quality objectives/criteria from the CCME and US EPA. The ECOTOX database reports toxicity data for a wide range of aquatic species as well as laboratory and field studies. For most chemicals, ECOTOX includes toxicity data in literature from 1972 to the present. All data have been quality assured according to the U.S. EPA's criteria, and the system is updated quarterly (U.S. EPA 2012). CSA (2012) also supports the use of ECOTOX as a source of information. The following principles were applied in the data selection:

- Endpoints involving growth, reproduction and survival were considered to be relevant to persistence of aquatic populations (consistent with CSA 2012);
- Only freshwater toxicity studies were considered;
- Records without test duration, endpoint and exposure concentration were eliminated;
- Chronic toxicity data were preferred in the selection (favoured by CSA 2012 as well). When chronic data were not sufficient (minimum of 2), acute data were considered and converted to chronic values;
- Chronic EC20 concentrations were preferred (consistent with CSA 2012). If not reported, other endpoints were considered and adjusted to an estimated EC20 value (see discussion below).

If more than 20 chronic EC20 were available in each taxonomic group, a 5<sup>th</sup> percentile of the EC20 distribution was used as a chosen TRV; if there were less than 20 chronic EC20 values, the lowest EC20 was used as a chosen TRV for the taxonomic category. The lowest chronic EC20 or 5th percentile of chronic EC20s derived from the above process were compared with widely used TRVs in ecological risk assessment recommended by Suter and Tsao (1996), U.S. EPA, CCME or other government guideline documents. The more appropriate values were selected as the chosen TRV for each taxonomic category in this review.

Table 6.29 presents the final TRV values selected for aquatic biota.

Table 6.29 EcoRA TRVs for Aquatic Biota (mg/L)

COPCs	Final TRV	Ecological Receptor	Notes
Al	No Data	Fish (benthic)	-
	No Data	Fish (pelagic)	-
	No Data	Aquatic Vegetation	-
	No Data	Benthic Invertebrates	-
Ammonia (Un-ionized)*	0.049	Fish (benthic)	Lowest un-ionized EC20, from US EPA (1999b): value derived from 1.85 mg/L total ammonia value, normalized to pH 8 and 25°C.
	0.019	Fish (pelagic)	No chronic values obtained from ECOTOX. Lowest un-ionized EC20 is 0.017 mg/L, derived from the US EPA (1999b) value of 2.6 mg/L total ammonia normalized to pH 8 and 25°C. The CCME guideline for protection of aquatic life is 0.019 mg/L un-ionized. Therefore, the CCME value is selected.
	0.96	Aquatic Vegetation	Toxicity data not available. The lowest un-ionized ammonia EC20 for phytoplankton (0.96 mg/L, Przytocka-Jusiak 1976; from ECOTOX) is used.
	0.044	Benthic Invertebrates	Lowest un-ionized EC20 from ECOTOX. 10-day oligochaete worm study (Schubauer-Berigan <i>et al.</i> 1995).
As	0.123	Fish (benthic)	Lowest EC20 among 2 studies (from ECOTOX) that meet the usage conditions (see discussion before table). 7-day study on goldfish (Birge <i>et al.</i> 1979).
	0.630	Fish (pelagic)	ECOTOX chronic data do not list the endpoint studied, and therefore are not acceptable for use. Instead, acute toxicity data were obtained and screened resulting in 50 records encompassing several different species. These were converted from acute LC50 to chronic EC20, and the 5 <sup>th</sup> percentile of the data was used.
	0.252	Aquatic Vegetation	Lowest value from 8 studies from ECOTOX, converted to EC20, that meet the usage conditions (see discussion before table). 14-day study on duckweed (Jenner & Janssen-Mommen 1993).
	0.122	Benthic Invertebrates	5 <sup>th</sup> percentile of data from 27 studies from ECOTOX, converted to EC20, that meet the usage conditions (see discussion before table).
Ba	400	Fish (benthic)	US EPA ECOTOX Database (US EPA 2015)
	42.7	Fish (pelagic)	
	25	Aquatic Vegetation	
	8.9	Benthic Invertebrates	

COPCs	Final TRV	Ecological Receptor	Notes
Cd	0.00081	Fish (benthic)	5 <sup>th</sup> percentile of data from 35 studies from ECOTOX, converted to EC20, that meet the usage conditions (see discussion before table). Adjusted to water hardness of 150 mg/L CaCO <sub>3</sub> .
	0.00093	Fish (pelagic)	5 <sup>th</sup> percentile of data from 73 studies from ECOTOX, converted to EC20, that meet the usage conditions (see discussion before table). Adjusted to water hardness of 150 mg/L CaCO <sub>3</sub> .
	0.00763	Aquatic Vegetation	5 <sup>th</sup> percentile of data from 35 studies from ECOTOX, converted to EC20, that meet the usage conditions (see discussion before table).
	0.00137	Benthic Invertebrates	5 <sup>th</sup> percentile of data from 49 studies from ECOTOX, converted to EC20, that meet the usage conditions (see discussion before table). Adjusted to water hardness of 150 mg/L CaCO <sub>3</sub> .
Cl-	598	Fish (benthic)	Lowest value among <i>chronic</i> chloride fish toxicity studies in CCME (2011).
	607	Fish (pelagic)	Chronic chloride NOEC for brown trout, based on an 8-day study, survival endpoint. (CCME 2011).
	1171	Aquatic Vegetation	Lowest value among <i>chronic</i> chloride toxicity studies in CCME (2011) for aquatic plants and algae. 96-hour study on duckweed, growth endpoint.
	12	Benthic Invertebrates	Lowest LOEC among <i>chronic</i> chloride benthic invertebrate toxicity studies in CCME (2011).
F	18	Fish (benthic)	Several ECOTOX chronic data do not list the endpoint studied, and therefore are not acceptable for use. Instead, ECOTOX acute toxicity data were obtained and screened resulting in 7 records encompassing fathead minnow and western mosquitofish. The minimum of these acute values was selected and converted from acute LC50 to chronic EC20. The underlying Smith <i>et al.</i> (1985) study is a 4-day LC50 mortality study using fathead minnow.
	16.025	Fish (pelagic)	Lowest value from 5 studies from ECOTOX, converted to EC20, that meet the usage conditions (see discussion before table). 8-day LC50 study on rainbow trout (Camargo and Tarazona, 1991).
	128	Aquatic Vegetation	Single study available from ECOTOX that reported a concentration effect. Selected by default. Based on a 6-day growth study on rice (Wang 1994).
	4.638	Benthic Invertebrates	5 <sup>th</sup> percentile value from among 21 studies from ECOTOX (that met the usage conditions – see discussion before table) and 1 study from CCME (2002). Data converted to EC20 where required.

Final – Environmental Risk Assessment for the Cameco Port Hope Conversion Facility

COPCs	Final TRV	Ecological Receptor	Notes
K	667	Fish (benthic)	US EPA ECOTOX Database (US EPA 2015)
	No Data	Fish (pelagic)	
	1337	Aquatic Vegetation	
	119	Benthic Invertebrates	
Sr	2.145	Fish (benthic)	Single study available from ECOTOX that met the usage conditions (see discussion before table). Selected by default. 7-day LC50 mortality study on goldfish (Birge 1978), converted to EC20.
	0.050	Fish (pelagic)	Lowest value from 2 studies from ECOTOX, converted to EC20, that meet the usage conditions (see discussion before table). 28-day LC50 mortality study on trout (Birge 1978).
	1,000	Aquatic Vegetation	Toxicity data not available. Phytoplankton is therefore used as a surrogate. For phytoplankton, ECOTOX provides only 2 records, neither of which provide specific endpoints. As such, a conversion to EC20 cannot be made. The effect concentration of both of these records has been used (Bringmann and Kuhn 1959a,b).
	0.250	Benthic Invertebrates	Lowest value from 3 studies from ECOTOX, converted to EC20, that meet the usage conditions (see discussion before table). 7-day LC50 mortality study on <i>Hyalella azteca</i> (Borgmann <i>et al.</i> 2005).
U	1.5	Fish (benthic)	VST (2004) and Liber <i>et al.</i> (2007). 31-day toxicity study involving fathead minnows with increasing water hardness produced EC25s for growth of 1.3, 1.5, 2 and 2 mg/L for water hardness of 15, 60, 120, and 240 mg/L CaCO <sub>3</sub> , respectively. A value of 1.5 mg/L, corresponding to a water hardness of 60 mg/L, was selected.
	0.55	Fish (pelagic)	VST (2004) and Liber <i>et al.</i> (2007). 31-day toxicity study involving rainbow trout with increasing water hardness produced an EC25 for growth of 0.34 mg/L for water hardness of 5 mg/L CaCO <sub>3</sub> , and an LC25 of 0.55 mg/L for water hardness of 60 mg/L CaCO <sub>3</sub> . The value of 0.55 mg/L, corresponding to a water hardness of 60 mg/L, was selected.
	5.5	Aquatic Vegetation	VST (2004). 7-day uranium toxicity study on duckweed, using a growth endpoint, for different water hardness. The geometric mean of results for 60 mg/L CaCO <sub>3</sub> water hardness is 5.5 mg/L.
	0.027	Benthic Invertebrates	Liber <i>et al.</i> (2007). 28-day toxicity study on <i>hyalella Azteca</i> using a growth endpoint, based on a water hardness of 60 mg/L CaCO <sub>3</sub> .

Final – Environmental Risk Assessment for the Cameco Port Hope Conversion Facility

COPCs	Final TRV	Ecological Receptor	Notes
Zn	0.073	Fish (benthic)	Lowest value from 15 studies from ECOTOX, converted to EC20, that meet the usage conditions (see discussion before table). 8-day LC50 mortality study on fathead minnow (Popken 1990). Adjusted to a water hardness of 150 mg/L CaCO <sub>3</sub> .
	0.145	Fish (pelagic)	5 <sup>th</sup> percentile value from among 39 studies from ECOTOX that met the usage conditions – see discussion before table. Data converted to EC20 where required. Adjusted to a water hardness of 150 mg/L CaCO <sub>3</sub> .
	0.0.077	Aquatic Vegetation	Lowest value from 7 studies from ECOTOX, converted to EC20, that meet the usage conditions (see discussion before table). 14-day EC50 study on duckweed (Jenner and Janssen-Mommen 1993). Adjusted to a water hardness of 150 mg/L CaCO <sub>3</sub> .
	0.0101	Benthic Invertebrates	Lowest value from 14 studies from ECOTOX, converted to EC20, that meet the usage conditions (see discussion before table). 10-day LC50 mortality study on midges (Anderson <i>et al.</i> 1980). Adjusted to a water hardness of 150 mg/L CaCO <sub>3</sub> .

Note:

\* Toxicity data were pre-screened for ambient pH and temperature conditions. Temperature conditions also used to convert to un-ionized form.

### 6.3.2 Radiological Dose Benchmarks

The recommended radiological dose benchmarks from CSA N288.6 (2012) are used in this study. For more information on the rationale for selecting these benchmarks, the reader is referred to the CSA (2012) document.

Table 6.30 presents the final radiological dose benchmarks selected for both aquatic and terrestrial biota.

Table 6.30 EcoRA Radiological Dose Benchmarks (mGy/d)

CSA (2012)

Category	Organism	Dose Rate Benchmark
Aquatic Biota	Fish (benthic & pelagic)	9.6 mGy/d
	Aquatic Vegetation	9.6 mGy/d
	Benthic Invertebrates	9.6 mGy/d
Terrestrial Biota	Terrestrial Animals	2.4 mGy/d
	Terrestrial Plants	2.4 mGy/d

## 6.4 Risk Characterization

This section presents the risk results (SIs) calculated for each receptor-COPC combination, based on the exposure estimates outlined in Section 6.2.8 and the toxicity benchmarks outlined in Section 6.3. [REDACTED]

### 6.4.1 Risk Results – Radiological

#### 6.4.1.1 Terrestrial (Radiological)

Table 6.31 presents radiological dose estimates for terrestrial receptors, along with the corresponding dose benchmark and a SI comparison. Limited radionuclide data are available for the on-site gravel, on-site grass and residential yard exposure locations.

Table 6.31 EcoRA Radiological Dose (mGy/d) & SI Results - Terrestrial

#### a) On-Site Grass

Radionuclide	Earthworm (soil)	Vegetation
Pb-210	ND	ND
Po-210	ND	ND
Ra-224	ND	ND
Ra-226	ND	ND
Ra-228	ND	ND
Th-228	ND	ND
Th-230	ND	ND
Th-232	ND	ND
U-234	9.62E-04	3.85E-04
U-235	1.14E-03	5.92E-04
U-238	3.99E-05	1.58E-05
External gamma*	NA	8.1E-03
<b>Total (mGy/d)</b>	<b>2.14E-03</b>	<b>9.09E-03</b>
<b>Benchmark (mGy/d)</b>	<b>2.4</b>	<b>2.4</b>
<b>SI</b>	<b>8.91E-04</b>	<b>3.79E-03</b>

Notes:

ND – No Data: The particular radionuclide data are not available for this exposure location.

NA – Not an applicable pathway.

\* - 2014 maximum measured gamma reading from Cameco monthly fenceline measurements.

Final – Environmental Risk Assessment for the Cameco Port Hope Conversion Facility

b) Off-Site Grass Strip

Radionuclide	American Robin	Cottontail Rabbit	Earthworm (soil)	Great Horned Owl	Meadow Vole	Red Fox	Vegetation	Yellow Warbler
Pb-210	6.47E-04	7.77E-06	2.02E-03	2.14E-05	3.93E-06	1.60E-05	3.06E-05	9.97E-04
Po-210	1.55E-02	1.29E-03	8.00E-04	8.50E-03	1.87E-04	3.96E-04	3.07E-04	1.51E-02
Ra-224	8.66E-08	3.98E-07	0.00E+00	7.71E-08	3.30E-07	4.63E-07	0.00E+00	1.22E-07
Ra-226	3.07E-01	3.55E-01	1.05E+00	2.19E-01	3.78E-01	2.54E-01	7.04E-01	3.04E-01
Ra-228	4.14E-10	1.90E-09	0.00E+00	3.69E-10	1.58E-09	2.21E-09	0.00E+00	5.85E-10
Th-228	2.79E-04	2.69E-04	5.14E-04	2.21E-04	3.86E-04	2.45E-04	2.88E-04	2.78E-04
Th-230	5.66E-04	5.52E-04	3.61E-03	2.91E-04	8.70E-05	1.48E-04	3.09E-03	5.34E-04
Th-232	6.46E-06	6.33E-06	4.15E-05	3.31E-06	9.54E-07	1.68E-06	3.56E-05	6.11E-06
U-234	3.02E-01	5.32E-03	1.34E-01	1.26E-01	8.13E-04	1.77E-03	5.38E-02	3.21E-01
U-235	1.46E-02	1.44E-03	7.30E-03	6.61E-03	1.38E-03	1.19E-03	3.81E-03	1.55E-02
U-238	2.93E-02	5.18E-04	1.31E-02	1.23E-02	7.81E-05	1.71E-04	5.18E-03	3.13E-02
External gamma*	8.10E-03	8.10E-03	NA	8.10E-03	8.10E-03	8.10E-03	8.10E-03	8.10E-03
<b>Total (mGy/d)</b>	<b>6.78E-01</b>	<b>3.72E-01</b>	<b>1.21E+00</b>	<b>3.81E-01</b>	<b>3.89E-01</b>	<b>2.66E-01</b>	<b>7.79E-01</b>	<b>6.96E-01</b>
<b>Benchmark (mGy/d)</b>	<b>2.4</b>	<b>2.4</b>	<b>2.4</b>	<b>2.4</b>	<b>2.4</b>	<b>2.4</b>	<b>2.4</b>	<b>2.4</b>
<b>SI</b>	<b>2.82E-01</b>	<b>1.55E-01</b>	<b>5.06E-01</b>	<b>1.59E-01</b>	<b>1.62E-01</b>	<b>1.11E-01</b>	<b>3.25E-01</b>	<b>2.90E-01</b>

Notes:

NA – Not an applicable pathway.

\* - 2014 maximum measured gamma reading from Cameco monthly fenceline measurements.



**c) On-Site Gravel**

Radionuclide	Earthworm (soil)
Pb-210	ND
Po-210	ND
Ra-224	ND
Ra-226	4.93E-01
Ra-228	0.00E+00
Th-228	6.42E-05
Th-230	7.80E-05
Th-232	2.07E-06
U-234	ND
U-235	ND
U-238	ND
<b>Total</b>	<b>4.93E-01</b>
<b>Benchmark</b>	<b>2.4</b>
<b>SI</b>	<b>2.05E-01</b>

Notes:

ND – No Data: The particular radionuclide data are not available for this exposure location.  
 External gamma not applied to sub-surface receptors.

**d) On-Site Groundwater (Earthworm only)**

Radionuclide	Earthworm (gw)
Pb-210	1.15E-05
Po-210	2.23E-05
Ra-224	3.27E-02
Ra-226	2.99E-03
Ra-228	1.56E-04
Th-228	4.32E-04
Th-230	5.18E-05
Th-232	1.10E-05
U-234	8.75E-01
U-235	2.50E-02
U-238	8.18E-01
<b>Total</b>	<b>1.75E+00</b>
<b>Benchmark</b>	<b>2.4</b>
<b>SI</b>	<b>7.3E-01</b>

Note:

External gamma not applied to sub-surface receptors.

Final – Environmental Risk Assessment for the Cameco Port Hope Conversion Facility

e) Residential Yards

Radionuclide	American Robin	Cottontail Rabbit	Earthworm (soil)	Great Horned Owl	Meadow Vole	Red Fox	Vegetation	Yellow Warbler
Pb-210	ND	ND	ND	ND	ND	ND	ND	ND
Po-210	ND	ND	ND	ND	ND	ND	ND	ND
Ra-224	ND	ND	ND	ND	ND	ND	ND	ND
Ra-226	ND	ND	ND	ND	ND	ND	ND	ND
Ra-228	ND	ND	ND	ND	ND	ND	ND	ND
Th-228	ND	ND	ND	ND	ND	ND	ND	ND
Th-230	ND	ND	ND	ND	ND	ND	ND	ND
Th-232	ND	ND	ND	ND	ND	ND	ND	ND
U-234	8.72E-04	1.56E-05	3.85E-04	3.69E-04	2.60E-06	5.45E-06	1.54E-04	9.31E-04
U-235	4.38E-05	4.27E-06	2.16E-05	2.01E-05	4.09E-06	3.54E-06	1.12E-05	4.67E-05
U-238	7.72E-04	1.38E-05	3.42E-04	3.26E-04	2.27E-06	4.78E-06	1.35E-04	8.27E-04
External gamma*	8.10E-03	8.10E-03	NA	8.10E-03	8.10E-03	8.10E-03	8.10E-03	8.10E-03
<b>Total (mGy/d)</b>	<b>9.79E-03</b>	<b>8.13E-03</b>	<b>7.49E-04</b>	<b>8.82E-03</b>	<b>8.11E-03</b>	<b>8.11E-03</b>	<b>8.40E-03</b>	<b>9.90E-03</b>
<b>Benchmark (mGy/d)</b>	<b>2.4</b>	<b>2.4</b>	<b>2.4</b>	<b>2.4</b>	<b>2.4</b>	<b>2.4</b>	<b>2.4</b>	<b>2.4</b>
<b>SI</b>	<b>4.08E-03</b>	<b>3.39E-03</b>	<b>3.12E-04</b>	<b>3.67E-03</b>	<b>3.38E-03</b>	<b>3.38E-03</b>	<b>3.50E-03</b>	<b>4.13E-03</b>

Notes:

ND – No Data: The particular radionuclide data are not available for this exposure location.

NA – Not an applicable pathway.

\* - 2014 maximum measured gamma reading from Cameco monthly fenceline measurements.

### 6.4.1.2 Aquatic (Radiological)

Table 6.32 presents radiological dose results for aquatic receptors, for both the harbour and lake (beach) locations, along with the corresponding dose benchmark and SI comparison.

Table 6.32 EcoRA - Radiological Dose (mGy/d) & SI Results (Aquatic)

Exposure Location	Radionuclide	Aquatic Vegetation	Benthic Fish	Benthic Invertebrates	Horned Grebe	Lesser Scaup	Pelagic Fish
Harbour	Pb-210	4.55E-07	3.24E-03	3.24E-03	9.66E-04	6.71E-04	1.44E-05
	Po-210	7.45E-03	1.39E-04	7.45E-02	7.60E-02	5.40E-02	1.34E-04
	Ra-224	1.06E-04	4.74E-03	1.88E-02	6.37E-05	7.56E-05	4.39E-03
	Ra-226	5.52E-06	1.07E-01	4.35E-01	8.00E-03	5.63E-03	1.00E-01
	Ra-228*	6.48E-05	2.47E-04	3.15E-04	3.93E-07	4.55E-07	8.53E-05
	Th-228	4.76E-02	4.33E-03	2.51E-03	4.58E-06	3.81E-06	4.32E-03
	Th-230	7.14E-03	2.23E-03	1.97E-03	4.21E-04	2.92E-04	6.17E-04
	Th-232	6.06E-03	5.25E-04	3.05E-04	5.44E-07	4.51E-07	5.23E-04
	U-234	1.57E-02	2.49E-04	8.28E-03	1.25E-03	9.22E-04	1.79E-04
	U-235	1.31E-03	2.74E-04	9.46E-04	5.82E-05	4.53E-05	1.50E-05
	U-238	2.94E-02	4.16E-04	1.66E-02	2.63E-03	1.94E-03	3.61E-04
	External gamma*	NA	NA	NA	8.10E-03	8.10E-03	NA
	<b>Total (mGy/d)</b>	<b>1.15E-01</b>	<b>1.23E-01</b>	<b>5.63E-01</b>	<b>9.75E-02</b>	<b>7.17E-02</b>	<b>1.11E-01</b>
	<b>Benchmark (mGy/d)</b>	<b>9.6</b>	<b>9.6</b>	<b>9.6</b>	<b>9.6</b>	<b>9.6</b>	<b>9.6</b>
<b>SI</b>	<b>1.20E-02</b>	<b>1.28E-02</b>	<b>5.86E-02</b>	<b>1.02E-02</b>	<b>7.47E-03</b>	<b>1.15E-02</b>	

Final – Environmental Risk Assessment for the Cameco Port Hope Conversion Facility

Exposure Location	Radionuclide	Aquatic Vegetation	Benthic Fish	Benthic Invertebrates	Horned Grebe	Lesser Scaup	Pelagic Fish
Lake (Beach)	Pb-210	ND	ND	ND	ND	ND	ND
	Po-210	ND	ND	ND	ND	ND	ND
	Ra-224	ND	ND	ND	ND	ND	ND
	Ra-226	1.38E-06	2.50E-02	1.07E-01	3.73E-05	4.43E-05	2.50E-02
	Ra-228	ND	ND	ND	ND	ND	ND
	Th-228	ND	ND	ND	ND	ND	ND
	Th-230	ND	ND	ND	ND	ND	ND
	Th-232	ND	ND	ND	ND	ND	ND
	U-234	1.57E-03	1.79E-05	8.21E-04	4.27E-06	8.58E-06	1.79E-05
	U-235	6.95E-05	7.95E-07	3.64E-05	1.97E-07	3.96E-07	7.96E-07
	U-238	3.07E-03	3.77E-05	1.73E-03	9.01E-06	1.81E-05	3.77E-05
	External gamma*	NA	NA	NA	8.10E-03	8.10E-03	8.10E-03
	<b>Total (mGy/d)</b>	<b>4.71E-03</b>	<b>2.51E-02</b>	<b>1.10E-01</b>	<b>8.15E-03</b>	<b>8.17E-03</b>	<b>3.32E-02</b>
	<b>Benchmark (mGy/d)</b>	<b>9.6</b>	<b>9.6</b>	<b>9.6</b>	<b>9.6</b>	<b>9.6</b>	<b>9.6</b>
<b>SI</b>	<b>4.91E-04</b>	<b>2.61E-03</b>	<b>1.14E-02</b>	<b>8.49E-04</b>	<b>8.51E-04</b>	<b>3.45E-03</b>	

Notes:

\* Assumed equal to Ra-224. See Table 2.1.

ND – No Data: Radionuclide data are not available for this exposure location.

NA – Not an applicable pathway.

\* - 2014 maximum measured gamma reading from Cameco monthly fence line measurements.

As seen in the above tables, the estimated doses to terrestrial and aquatic receptors are all below the corresponding benchmarks. All SI values are below one.

#### 6.4.2 Risk Results – Radiological (including Radon Rn-222)

The dose contribution from radon and progeny was included in the dose calculations for selected biota, i.e., those species that may spend a substantial portion of their time burrowed under (within) soil or sediment, and therefore may potentially be exposed to Rn-222 through their burrowing behaviour, or by otherwise residing within sediment or soil. In this ERA, the following biota were selected:

- Terrestrial Biota: Cotton Tail Rabbit, Meadow Vole, Red Fox and Earthworm; and
- Aquatic Biota: Benthic Invertebrate.

Additional radon contribution calculations are not necessary for benthic fish since benthic fish are present close to (i.e. immediately above) sediment, but not primarily *within* sediment. Benthic fish do receive an external dose from sediment though, and this *is* included in their dose and risk calculations.

The dose from radon to these species was assessed using methodology from Environment Canada/Health Canada (EC/HC 2003, PSL2), as recommended by the CNSC (see Report #1 of the SENES 2010 SWRA Update). The EC/HC (2003) methodology calculates the dose contribution from radon (Rn-222) by relating it to radium (Ra-226). The methodology assumes that the activity of Rn-222 is 30% of Ra-226 for internal dose, and 100% of Ra-226 for external dose. Therefore, the internal dose from Rn-222 is estimated to be 30% of the internal dose from its parent radionuclide Ra-226, and the external dose from Rn-222 is estimated to be 100% of the external dose from its parent radionuclide Ra-226. These estimated dose contributions are added to the Ra-226 dose estimate.

For terrestrial biota, this is a particularly conservative approach, because by applying the radon contribution to the entire estimated dose of Ra-226, it assumes that the biota spends all of its time (i.e., its entire exposure time and duration) burrowed.

The dose contribution is calculated separately for internal and external dose fractions. The equations used to calculate the contribution from Rn-222 to all biota are listed below:

**Internal Dose<sub>Rn-222</sub>:** Dose Contribution of Rn-222 = 30% of Internal Dose from Ra-226

**External Dose<sub>Rn-222</sub>:** Dose Contribution of Rn-222 = 100% of External Dose from Ra-226

**Total Dose from Rn-222:** Rn-222 Dose = [Internal dose<sub>Rn-222</sub>] + [External dose<sub>Rn-222</sub>]

**Radium Dose Including Rn-222 Contribution:**

Ra-226 Dose (with Rn-222 Contribution) = [Ra-226 Dose] + [Rn-222 Dose]

The dose received by terrestrial biota from Ra-226 (including Rn-222) was estimated by adjusting the existing internal and external dose fractions: the internal fraction was increased by 30%; and the external

fraction by 100%. These were then summed to produce the total dose from Ra-226 and Rn-222. The total dose received from all radionuclides was then calculated.

### 6.4.3 Updated Dose Calculations

The following data sets have been chosen for dose calculations:

- Aquatic Biota: Aquatic Harbour, Tier 1, Radiological Data; and
- Terrestrial Biota: Off-Site Grass Strip, Tier 1, Radiological Data.

To assess radon to aquatic biota (i.e. benthos), the Harbour case was selected, because measured data were available for radionuclides in both surface water and sediment. The Tier 1 (i.e., maximum measured) Ra-226 levels from sediment and surface water were used. Similarly, Tier 1 (i.e., maximum measured) Ra-226 levels in soil and surface water were used for the estimate of radon dose to terrestrial biota.

The following tables show dose breakdown for each biota, first without the contribution from Rn-222, and then including the dose contribution from Rn-222. It is important to note that doses from other radionuclides are not influenced by these changes, though the total dose received per biota is adjusted to reflect the addition of Rn-222.

Table 6.33 Original Dose Calculations for Benthos (excluding the contribution of Rn-222)

Radionuclide	Internal Dose	External Dose (Water)	External Dose (Sediment)	Total Dose	Total Dose
	(Gy/y)	(Gy/y)	(Gy/y)	(Gy/y)	(mGy/d)
Pb-210	4.62E-06	3.24E-09	1.18E-03	1.18E-03	3.24E-03
Po-210	2.72E-02	1.03E-13	1.83E-06	2.72E-02	7.45E-02
Ra-224	6.71E-03	1.94E-05	1.45E-04	6.87E-03	1.88E-02
Ra-226	1.56E-01	4.72E-07	2.48E-03	1.59E-01	4.35E-01
Ra-228	3.20E-05	1.18E-05	7.10E-05	1.15E-04	3.15E-04
Th-228	9.13E-04	1.93E-08	1.69E-06	9.15E-04	2.51E-03
Th-230	1.30E-04	9.63E-12	5.89E-04	7.19E-04	1.97E-03
Th-232	1.11E-04	7.23E-12	7.00E-07	1.11E-04	3.05E-04
U-234	3.00E-03	2.06E-10	2.54E-05	3.02E-03	8.28E-03
U-235	2.51E-04	4.03E-09	9.45E-05	3.45E-04	9.46E-04
U-238	6.04E-03	2.55E-08	1.99E-05	6.06E-03	1.66E-02

**Cumulative Dose** 5.63E-01  
**Benchmark Dose** 9.60E+00  
**Screening Index** 5.86E-02

Table 6.34 Updated Dose Calculations for Benthos (Ra-226 dose now includes the contribution of Rn-222 (highlighted))

Radionuclide	Internal Dose	External Dose (Water)	External Dose (Sediment)	Total Dose	Total Dose
	(Gy/y)	(Gy/y)	(Gy/y)	(Gy/y)	(mGy/d)
Pb-210	4.62E-06	3.24E-09	1.18E-03	1.18E-03	3.24E-03
Po-210	2.72E-02	1.03E-13	1.83E-06	2.72E-02	7.45E-02
Ra-224	6.71E-03	1.94E-05	1.45E-04	6.87E-03	1.88E-02
Ra-226	2.03E-01	9.44E-07	4.96E-03	2.08E-01	5.71E-01
Ra-228	3.20E-05	1.18E-05	7.10E-05	1.15E-04	3.15E-04
Th-228	9.13E-04	1.93E-08	1.69E-06	9.15E-04	2.51E-03
Th-230	1.30E-04	9.63E-12	5.89E-04	7.19E-04	1.97E-03
Th-232	1.11E-04	7.23E-12	7.00E-07	1.11E-04	3.05E-04
U-234	3.00E-03	2.06E-10	2.54E-05	3.02E-03	8.28E-03
U-235	2.51E-04	4.03E-09	9.45E-05	3.45E-04	9.46E-04
U-238	6.04E-03	2.55E-08	1.99E-05	6.06E-03	1.66E-02

**Cumulative Dose** 6.98E-01  
**Benchmark Dose** 9.60E+00  
**Screening Index** 7.27E-02

Table 6.35 Original Dose Calculations for Cotton Tail Rabbit (excluding the contribution of Rn-222)

Radionuclide	Internal Dose	External Dose	Total Dose	Total Dose
	(Gy/y)	(Gy/y)	(Gy/y)	(mGy/d)
Pb-210	9.98E-07	1.84E-06	2.84E-06	7.77E-06
Po-210	4.72E-04	9.46E-09	4.72E-04	1.29E-03
Ra-224	1.45E-07	0.00E+00	1.45E-07	3.98E-07
Ra-226	4.26E-02	8.69E-02	1.29E-01	3.55E-01
Ra-228	6.95E-10	0.00E+00	6.95E-10	1.90E-09
Th-228	7.03E-06	9.11E-05	9.81E-05	2.69E-04
Th-230	1.94E-04	7.13E-06	2.02E-04	5.52E-04
Th-232	2.24E-06	7.10E-08	2.31E-06	6.33E-06
U-234	1.90E-03	3.63E-05	1.94E-03	5.32E-03
U-235	8.45E-05	4.40E-04	5.24E-04	1.44E-03
U-238	1.86E-04	2.94E-06	1.89E-04	5.18E-04

**Cumulative Dose** 3.64E-01  
**Benchmark Dose** 2.40E+00  
**Screening Index** 1.52E-01



Table 6.36 Updated Dose Calculations for Cotton Tail Rabbit (including the contribution of Rn-222)

Radionuclide	Internal Dose	External Dose	Total Dose	Total Dose
	(Gy/y)	(Gy/y)	(Gy/y)	(mGy/d)
Pb-210	9.98E-07	1.84E-06	2.84E-06	7.77E-06
Po-210	4.72E-04	9.46E-09	4.72E-04	1.29E-03
Ra-224	1.45E-07	0.00E+00	1.45E-07	3.98E-07
Ra-226	5.53E-02	1.74E-01	2.29E-01	6.28E-01
Ra-228	6.95E-10	0.00E+00	6.95E-10	1.90E-09
Th-228	7.03E-06	9.11E-05	9.81E-05	2.69E-04
Th-230	1.94E-04	7.13E-06	2.02E-04	5.52E-04
Th-232	2.24E-06	7.10E-08	2.31E-06	6.33E-06
U-234	1.90E-03	3.63E-05	1.94E-03	5.32E-03
U-235	8.45E-05	4.40E-04	5.24E-04	1.44E-03
U-238	1.86E-04	2.94E-06	1.89E-04	5.18E-04
<b>Cumulative Dose</b>				<b>6.37E-01</b>
<b>Benchmark Dose</b>				<b>2.40E+00</b>
<b>Screening Index</b>				<b>2.65E-01</b>

Table 6.37 Original Dose Calculations for Meadow Vole (excluding the contribution of Rn-222)

Radionuclide	Internal Dose	External Dose	Total Dose	Total Dose
	(Gy/y)	(Gy/y)	(Gy/y)	(mGy/d)
Pb-210	2.72E-07	1.16E-06	1.43E-06	3.93E-06
Po-210	6.83E-05	1.45E-08	6.83E-05	1.87E-04
Ra-224	1.20E-07	0.00E+00	1.20E-07	3.30E-07
Ra-226	8.92E-03	1.29E-01	1.38E-01	3.78E-01
Ra-228	5.75E-10	0.00E+00	5.75E-10	1.58E-09
Th-228	1.03E-06	1.40E-04	1.41E-04	3.86E-04
Th-230	2.82E-05	3.57E-06	3.18E-05	8.70E-05
Th-232	3.25E-07	2.28E-08	3.48E-07	9.54E-07
U-234	2.86E-04	1.06E-05	2.97E-04	8.13E-04
U-235	1.27E-05	4.90E-04	5.03E-04	1.38E-03
U-238	2.79E-05	6.03E-07	2.85E-05	7.81E-05
<b>Cumulative Dose</b>				<b>3.81E-01</b>
<b>Benchmark Dose</b>				<b>2.40E+00</b>
<b>Screening Index</b>				<b>1.59E-01</b>

Table 6.38 Updated Dose Calculations for Meadow Vole (including the contribution of Rn-222)

Radionuclide	Internal Dose	External Dose	Total Dose	Total Dose
	(Gy/y)	(Gy/y)	(Gy/y)	(mGy/d)
Pb-210	2.72E-07	1.16E-06	1.43E-06	3.93E-06
Po-210	6.83E-05	1.45E-08	6.83E-05	1.87E-04
Ra-224	1.20E-07	0.00E+00	1.20E-07	3.30E-07
Ra-226	1.16E-02	2.58E-01	2.70E-01	7.38E-01
Ra-228	5.75E-10	0.00E+00	5.75E-10	1.58E-09
Th-228	1.03E-06	1.40E-04	1.41E-04	3.86E-04
Th-230	2.82E-05	3.57E-06	3.18E-05	8.70E-05
Th-232	3.25E-07	2.28E-08	3.48E-07	9.54E-07
U-234	2.86E-04	1.06E-05	2.97E-04	8.13E-04
U-235	1.27E-05	4.90E-04	5.03E-04	1.38E-03
U-238	2.79E-05	6.03E-07	2.85E-05	7.81E-05
<b>Cumulative Dose</b>				<b>7.41E-01</b>
<b>Benchmark Dose</b>				<b>2.40E+00</b>
<b>Screening Index</b>				<b>3.09E-01</b>

Table 6.39 Original Dose Calculations for Red Fox (excluding the contribution of Rn-222)

Radionuclide	Internal Dose	External Dose	Total Dose	Total Dose
	(Gy/y)	(Gy/y)	(Gy/y)	(mGy/d)
Pb-210	4.26E-06	1.59E-06	5.86E-06	1.60E-05
Po-210	1.45E-04	8.83E-09	1.45E-04	3.96E-04
Ra-224	1.69E-07	0.00E+00	1.69E-07	4.63E-07
Ra-226	1.15E-02	8.13E-02	9.28E-02	2.54E-01
Ra-228	8.07E-10	0.00E+00	8.07E-10	2.21E-09
Th-228	1.75E-06	8.76E-05	8.93E-05	2.45E-04
Th-230	4.78E-05	6.16E-06	5.40E-05	1.48E-04
Th-232	5.51E-07	6.31E-08	6.14E-07	1.68E-06
U-234	6.13E-04	3.23E-05	6.45E-04	1.77E-03
U-235	2.71E-05	4.06E-04	4.33E-04	1.19E-03
U-238	5.97E-05	2.62E-06	6.23E-05	1.71E-04
<b>Cumulative Dose</b>				<b>2.58E-01</b>
<b>Benchmark Dose</b>				<b>2.40E+00</b>
<b>Screening Index</b>				<b>1.08E-01</b>

Table 6.40 Updated Dose Calculations for Red Fox (including the contribution of Rn-222)

Radionuclide	Internal Dose	External Dose	Total Dose	Total Dose
	(Gy/y)	(Gy/y)	(Gy/y)	(mGy/d)
Pb-210	4.26E-06	1.59E-06	5.86E-06	1.60E-05
Po-210	1.45E-04	8.83E-09	1.45E-04	3.96E-04
Ra-224	1.69E-07	0.00E+00	1.69E-07	4.63E-07
Ra-226	1.49E-02	1.63E-01	1.78E-01	4.86E-01
Ra-228	8.07E-10	0.00E+00	8.07E-10	2.21E-09
Th-228	1.75E-06	8.76E-05	8.93E-05	2.45E-04
Th-230	4.78E-05	6.16E-06	5.40E-05	1.48E-04
Th-232	5.51E-07	6.31E-08	6.14E-07	1.68E-06
U-234	6.13E-04	3.23E-05	6.45E-04	1.77E-03
U-235	2.71E-05	4.06E-04	4.33E-04	1.19E-03
U-238	5.97E-05	2.62E-06	6.23E-05	1.71E-04
<b>Cumulative Dose</b>				<b>4.90E-01</b>
<b>Benchmark Dose</b>				<b>2.40E+00</b>
<b>Screening Index</b>				<b>2.04E-01</b>

Table 6.41 Original Dose Calculations for Earthworm (excluding the contribution of Rn-222)

Radionuclide	Internal Dose	External Dose	Total Dose	Total Dose
	(Gy/y)	(Gy/y)	(Gy/y)	(mGy/d)
Pb-210	7.37E-04	1.17E-06	7.38E-04	2.02E-03
Po-210	2.92E-04	1.45E-08	2.92E-04	8.00E-04
Ra-224	0.00E+00	0.00E+00	0.00E+00	0.00E+00
Ra-226	2.55E-01	1.29E-01	3.84E-01	1.05E+00
Ra-228	0.00E+00	0.00E+00	0.00E+00	0.00E+00
Th-228	4.73E-05	1.40E-04	1.87E-04	5.14E-04
Th-230	1.31E-03	3.57E-06	1.32E-03	3.61E-03
Th-232	1.51E-05	2.28E-08	1.51E-05	4.15E-05
U-234	4.91E-02	1.06E-05	4.91E-02	1.34E-01
U-235	2.18E-03	4.90E-04	2.67E-03	7.30E-03
U-238	4.79E-03	6.04E-07	4.79E-03	1.31E-02
<b>Cumulative Dose</b>				<b>1.21E+00</b>
<b>Benchmark Dose</b>				<b>2.40E+00</b>
<b>Screening Index</b>				<b>5.06E-01</b>

Table 6.42 Updated Dose Calculations for Earthworm (including the contribution of Rn-222)

Radionuclide	Internal Dose	External Dose	Total Dose	Total Dose
	(Gy/y)	(Gy/y)	(Gy/y)	(mGy/d)
Pb-210	7.37E-04	1.17E-06	7.38E-04	2.02E-03
Po-210	2.92E-04	1.45E-08	2.92E-04	8.00E-04
Ra-224	0.00E+00	0.00E+00	0.00E+00	0.00E+00
Ra-226	3.31E-01	2.58E-01	5.89E-01	1.61E+00
Ra-228	0.00E+00	0.00E+00	0.00E+00	0.00E+00
Th-228	4.73E-05	1.40E-04	1.87E-04	5.14E-04
Th-230	1.31E-03	3.57E-06	1.32E-03	3.61E-03
Th-232	1.51E-05	2.28E-08	1.51E-05	4.15E-05
U-234	4.91E-02	1.06E-05	4.91E-02	1.34E-01
U-235	2.18E-03	4.90E-04	2.67E-03	7.30E-03
U-238	4.79E-03	6.04E-07	4.79E-03	1.31E-02
			<b>Cumulative Dose</b>	<b>1.78E+00</b>
			<b>Benchmark Dose</b>	<b>2.40E+00</b>
			<b>Screening Index</b>	<b>7.40E-01</b>

#### 6.4.4 Discussion of Updated Dose Results for Biota

Overall, incorporating the contribution of Rn-222 causes an increase to the total dose of all selected biota. However, even with these increases, the total dose to each of the selected biota is well below their individual benchmark values. Screening indices remain below 1.0 for all of the selected biota, as presented in Table 6.43 below.

Table 6.43 Percent Difference Between Total Dose Without and With Rn-222 Contribution

Biota	Total Dose Excluding Rn-222	Total Dose Including Rn-222	Percent Increase
	(mGy/d)	(mGy/d)	(%)
Benthos	5.63E-01	6.98E-01	24%
Meadow Vole	3.81E-01	7.41E-01	94%
Earthworm	1.21E+00	1.78E+00	46%
Cotton-Tail Rabbit	3.64E-01	6.37E-01	75%
Red Fox	2.58E-01	4.90E-01	90%

## 6.4.5 Risk Results – Non-Radiological

### 6.4.5.1 Terrestrial (Non-Radiological)

Table 6.44 to Table 6.45 present the estimated non-radiological risk (SI) results for terrestrial receptors, based on their respective environmental media and exposure locations, including:

- A. On-Site Grass Patches;
- B. On-Site Gravel Areas;
- C. Off-Site Grass Strip;
- D. Residential Yards; and,
- E. Groundwater (*hypothetical case using earthworm receptors, for perspective on groundwater levels*).

Each of the 5 exposure locations (above) are assessed using the following calculations:

**Tier 1:** estimates are based on maximum concentrations in surface water and soil (all soil depths).

**Tier 2a:** estimates are based on 95<sup>th</sup> percentile concentrations in surface water and soil (all soil depths). Tier 2a calculations are limited to those COPCs that exceeded in Tier 1.

**Tier 2b:** estimates are based on 95% UCL percentile concentrations in surface water and soil for mobile receptors, and 95<sup>th</sup> percentiles for non-mobile biota; however, soil depths beyond 0.5 meters below ground surface (mbgs) are excluded since the 0 - 0.5 mbgs soil depth represents the stratum inhabited by vegetation and soil invertebrates (i.e. the soil these receptors could be exposed to). For applicable biota, Tier 2b calculations also account for the home range fraction of the exposure location, as described in Section 6.2.3. Tier 2b calculations are limited to those COPCs that exceeded in Tier 2a.

**Tier 2c:** estimates are based on the leachable fractions of select metal COPCs based on the results of the leaching tests completed as part of the 2009 SWRA (see SENES 2009a, Appendix S, for further information on leach testing). Soil depths beyond 0.5 meters below ground surface (mbgs) are excluded since the 0 – 0.5 mbgs soil depth represents the stratum inhabited by vegetation and soil invertebrates (i.e. the soil these receptors could be exposed to). Tier 2c calculations are limited to those COPCs that exceeded in Tier 2b.

**TIER 1 EcoRA RESULTS:**

Table 6.44 EcoRA - Non-Radiological Risk Results – Terrestrial Receptors (Tier 1)

**a) On-Site Grass Patches**

<b>COPC</b>	<b>Earthworm (soil)</b>	<b>Vegetation</b>
Aluminium	1.3E+02	1.3E+02
Arsenic	1.5E+00	1.5E+00
Barium	3.4E-02	3.4E-02
Boron (HWS)	4.0E-01	4.0E-01
Cadmium	3.4E-02	3.4E-02
Cobalt	6.4E-02	6.4E-02
Copper	5.7E-02	5.7E-02
Fluoride	1.8E-02	1.8E-02
Iron	7.0E+01	7.0E+01
Lead	1.3E-02	1.3E-02
Magnesium	NC	NC
Manganese	1.2E+00	2.4E+00
Nickel	2.4E-02	2.4E-02
Nitrate	NC	NC
Potassium	1.8E+02	1.8E+02
Selenium	1.7E-01	1.7E-01
Strontium	NC	NC
Uranium	1.2E-02	1.2E-02
Vanadium	8.0E-02	8.0E-02
Zinc	6.2E-02	6.2E-02

Notes:

Bold – indicates where the estimated SI is greater than one.

The following analytes do not have available data in this medium/location: ammonia, nitrite, bromide, chloride, phosphate, sulphate, radionuclides, PHCs and PCBs.

Boron (HWS) – Hot Water Soluble Boron.

NC – Not Calculated: key parameters (e.g., data, TRV, or TF) not available.

**b) On-Site Gravel Areas**

<b>COPCs</b>	<b>Earthworm (soil)</b>
Aluminium	<b>7.0E+02</b>
Ammonia	NC
Arsenic	<b>2.3E+01</b>
Barium	1.4E-01
Boron (HWS)	8.8E-01
Bromide	1.7E-02
Cadmium	2.9E-01
Chloride	2.8E-01
Cobalt	<b>1.4E+00</b>
Copper	<b>2.3E+00</b>
Fluoride	2.4E-01
Iron	<b>6.5E+02</b>
Lead	5.6E-01
Magnesium	NC
Manganese	<b>8.0E+00</b>
Nickel	<b>1.2E+00</b>
Nitrate	NC
Nitrite	NC
Phosphate	NC
Potassium	<b>2.9E+02</b>
Selenium	2.3E-01
Strontium	NC
Sulphate	NC
Uranium	6.8E-01
Vanadium	6.5E-01
Zinc	4.7E-01

Notes:

Bold – indicates where the estimated SI is greater than one.

The following analytes do not have available data in this medium/location: PHCs and PCBs.

Boron (HWS) – Hot Water Soluble Boron.

NC – Not Calculated: key parameters (e.g., data, TRV, or TF) not available.

Final – Environmental Risk Assessment for the Cameco Port Hope Conversion Facility

c) Off-Site Grass Strip

COPC	American Robin	Cottontail Rabbit	Earthworm	Great Horned Owl	Meadow Vole	Red Fox	Vegetation	Yellow Warbler
Aluminium	NC	NC	<b>3.2E+02</b>	NC	NC	NC	<b>3.2E+02</b>	NC
Ammonia (Total)	NC	NC	NC	NC	NC	NC	NC	NC
Antimony	NC	5.6E-01	NA	NC	1.9E-01	3.7E-01	NA	NC
Arsenic	<b>1.8E+01</b>	<b>3.8E+00</b>	<b>4.6E+01</b>	<b>1.3E+00</b>	3.4E-01	<b>1.4E+00</b>	<b>4.6E+01</b>	<b>1.0E+01</b>
Barium	3.7E-01	9.8E-02	2.9E-01	2.6E-02	3.9E-02	5.4E-02	2.9E-01	2.3E-01
Boron	1.8E-01	7.0E-02	<b>3.0E+00</b>	3.2E-03	6.6E-02	7.6E-03	<b>3.0E+00</b>	5.5E-02
Cadmium	2.7E-01	4.8E-03	7.5E-02	2.2E-03	4.2E-03	3.2E-02	7.5E-02	2.1E-01
Cobalt	<b>4.4E+00</b>	4.7E-01	<b>3.8E+01</b>	5.2E-01	2.0E-01	3.4E-01	<b>3.8E+01</b>	<b>3.6E+00</b>
Copper	<b>2.7E+01</b>	<b>2.8E+00</b>	<b>3.8E+01</b>	<b>1.0E+00</b>	3.4E-01	<b>5.1E+00</b>	<b>3.8E+01</b>	<b>1.1E+01</b>
Fluoride	<b>7.8E+00</b>	2.5E-01	7.3E-01	6.2E-01	1.3E-01	1.4E-01	7.3E-01	<b>4.5E+00</b>
Iron	NC	NC	<b>6.5E+02</b>	NC	NC	NC	<b>6.5E+02</b>	NC
Lead	<b>3.7E+02</b>	<b>4.8E+00</b>	<b>2.7E+01</b>	<b>7.2E+00</b>	<b>1.1E+01</b>	<b>5.1E+01</b>	<b>2.7E+01</b>	<b>2.9E+02</b>
Manganese	2.6E-01	4.1E-01	<b>4.2E+00</b>	1.4E-02	2.8E-01	1.5E-01	<b>8.6E+00</b>	1.4E-01
Nickel	<b>3.6E+01</b>	<b>1.7E+00</b>	<b>2.1E+01</b>	7.7E-01	1.4E-01	4.3E-01	<b>2.1E+01</b>	<b>1.4E+01</b>
PCBs	NA	NA	3.6E-01	NA	NA	NA	3.6E-01	NA
PHC F1	NA	NA	7.7E-01	NA	NA	NA	7.7E-01	NA
PHC F2	NC	NC	<b>1.2E+01</b>	NC	NC	NC	<b>1.2E+01</b>	NC
PHC F3	NC	NC	<b>8.2E+01</b>	NC	NC	NC	<b>8.2E+01</b>	NC
Potassium	NC	NC	<b>7.1E+02</b>	NC	NC	NC	<b>7.1E+02</b>	NC
Selenium	<b>2.3E+00</b>	1.0E-01	<b>1.6E+00</b>	2.4E-02	7.4E-02	6.8E-01	<b>1.6E+00</b>	<b>1.2E+00</b>
Strontium	8.8E-02	3.0E-02	NC	5.0E-03	2.4E-02	4.4E-03	NC	4.5E-02
Uranium	<b>2.8E+00</b>	<b>2.6E+00</b>	<b>1.7E+00</b>	5.5E-01	<b>9.4E-01</b>	6.1E-01	<b>1.7E+00</b>	<b>3.4E+00</b>
Vanadium	NA	NA	6.3E-01	NA	NA	NA	6.3E-01	NA
Zinc	<b>4.9E+00</b>	4.7E-03	<b>1.7E+00</b>	7.0E-02	4.0E-03	<b>1.2E+00</b>	<b>1.7E+00</b>	<b>1.5E+00</b>

Notes:

Bold – indicates where the estimated SI is greater than one.

The following analytes do not have available data in this medium/location: Bromide, Chloride, Magnesium, Nitrate, Nitrite, Phosphate and Sulphate.

Total boron assessed for terrestrial mammals and birds, hot water soluble boron assessed for vegetation and earthworms.

NA – Not applicable: parameter not retained as a COPC for the applicable biota.

NC – Not Calculated: key parameters (e.g., data, TRV, or TF) not available.



Final – Environmental Risk Assessment for the Cameco Port Hope Conversion Facility

**d) Residential Yards**

COPC	American Robin	Cottontail Rabbit	Earthworm	Meadow Vole	Vegetation	Yellow Warbler
Aluminium	NC	NC	<b>5.1E+02</b>	NC	<b>5.1E+02</b>	NC
Antimony	NC	9.0E-02	NA	3.1E-02	NA	NC
Arsenic	6.6E-01	1.4E-01	<b>1.7E+00</b>	1.3E-02	<b>1.7E+00</b>	3.8E-01
Barium	1.2E-01	3.2E-02	9.3E-02	1.3E-02	9.3E-02	7.6E-02
Boron	2.0E-01	7.6E-02	<b>4.3E+00</b>	7.1E-02	<b>4.3E+00</b>	6.0E-02
Cadmium	1.5E-01	2.6E-03	4.2E-02	2.3E-03	4.2E-02	1.2E-01
Cobalt	4.1E-02	4.3E-03	3.5E-01	1.8E-03	3.5E-01	3.3E-02
Copper	2.0E-01	2.1E-02	2.9E-01	2.6E-03	2.9E-01	8.4E-02
Iron	NC	NC	<b>1.6E+02</b>	NC	<b>1.6E+02</b>	NC
Lead	<b>5.2E+00</b>	6.7E-02	3.8E-01	1.6E-01	3.8E-01	<b>4.0E+00</b>
Manganese	7.8E-02	1.2E-01	<b>1.3E+00</b>	8.4E-02	<b>2.6E+00</b>	4.1E-02
Nickel	2.2E-01	1.1E-02	1.3E-01	8.3E-04	1.3E-01	8.5E-02
Selenium	1.4E-01	6.5E-03	1.0E-01	4.8E-03	1.0E-01	7.3E-02
Strontium	3.3E-02	1.1E-02	NC	9.0E-03	NC	1.7E-02
Uranium	8.3E-03	7.8E-03	5.0E-03	3.1E-03	5.0E-03	1.0E-02
Vanadium	NA	NA	2.9E-01	NA	2.9E-01	NA
Zinc	<b>2.5E+00</b>	2.3E-03	8.3E-01	2.0E-03	8.3E-01	7.7E-01

Bold – indicates where the estimated SI is greater than one.

The following analytes were identified as COPCs, but do not have concentration data available in off-site locations: nitrate, nitrite, fluoride, ammonia, bromide, chloride, phosphate, sulphate, potassium, magnesium, PHC fractions F1, F2 & F3 and PCBs.

Total boron assessed for terrestrial mammals and birds, hot water soluble boron assessed for vegetation and earthworms.

N/A – Not applicable: parameter not retained as a COPC for the applicable biota.

NC – Not Calculated: key parameters (e.g., data, TRV, or TF) not available.

Final – Environmental Risk Assessment for the Cameco Port Hope Conversion Facility

e) On-Site Groundwater

ContName	Earthworm (gw)
Aluminium	NC
Ammonia	NC
Calcium	NC
Chloride	<b>2.0E+02</b>
Copper	4.4E-02
Fluoride	<b>5.6E+00</b>
Iron	<b>1.6E+02</b>
Magnesium	NC
Manganese	<b>6.4E+00</b>
Nitrate	NC
PHC F1	NC
PHC F2	NC
PHC F3	NC
PHC F4	NC
Potassium	NC
Selenium	<b>1.2E+01</b>
Silver	9.0E-02
Sodium	<b>3.9E+03</b>
Strontium	NC
Sulphate	NC
TDS	NC
Uranium	<b>3.3E+00</b>
Zinc	<b>8.8E+00</b>

Notes:

Bold – indicates where the estimated SI is greater than one.

NC – Not Calculated: key parameters (e.g., data, TRV, or TF) not available.

**TIER 2A RESULTS:** (Those COPCs that exceeded in Tier 1)

Table 6.45 EcoRA – Non-Radiological Risk Results – Terrestrial Receptors (Tier 2a)

**a) On-Site Grass Patches**

COPC	Earthworm (soil)	Vegetation
Aluminium	<b>1.3E+02</b>	<b>1.3E+02</b>
Arsenic	<b>1.0E+00</b>	<b>1.0E+00</b>
Iron	<b>6.3E+01</b>	<b>6.3E+01</b>
Manganese	<b>1.0E+00</b>	<b>2.1E+00</b>
Potassium	<b>1.5E+02</b>	<b>1.5E+02</b>

Notes:

Bold – indicates where the estimated SI is greater than one.

**b) On-Site Gravel Areas**

COPCs	Earthworm (soil)
Aluminium	<b>1.8E+02</b>
Arsenic	9.4E-01
Cobalt	1.1E-01
Copper	1.4E-01
Iron	<b>1.1E+02</b>
Manganese	9.2-01
Nickel	9.3E-02
Potassium	<b>9.2E+01</b>

Notes:

Bold – indicates where the estimated SI is greater than one.

Final – Environmental Risk Assessment for the Cameco Port Hope Conversion Facility

c) Off-Site Grass Strip (those COPCs that exceeded in Tier 1)

COPC	American Robin	Cottontail Rabbit	Earthworm	Great Horned Owl	Meadow Vole	Red Fox	Vegetation	Yellow Warbler
Aluminium	NE	NE	1.4E+02	NE	NE	NE	1.4E+02	NE
Arsenic	7.5E-01	1.6E-01	1.9E+00	5.2E-02	1.4E-02	6.0E-02	1.9E+00	4.3E-01
Barium	NE	NE	NE	NE	NE	NE	NE	NE
Boron	NE	NE	3.5E-01	NE	NE	NE	3.5E-01	NE
Cobalt	1.5E-02	NE	1.3E-01	NE	NE	NE	1.3E-01	1.2E-02
Copper	1.3E-01	1.3E-02	1.8E-01	4.9E-03	1.6E-03	2.4E-02	1.8E-01	5.3E-02
Fluoride	6.1E+00	NE	NE	NE	NE	NE	NE	3.6E+00
Iron	NE	NE	8.0E+01	NE	NE	NE	8.0E+01	NE
Lead	1.1E+00	1.4E-02	8.2E-02	2.2E-02	3.4E-02	1.5E-01	8.2E-02	8.6E-01
Manganese	NE	8.2E-02	8.4E-01	NE	NE	NE	1.7E+00	NE
Nickel	1.2E-01	5.8E-03	7.0E-02	NE	NE	NE	7.0E-02	4.6E-02
Potassium	NE	NE	1.1E+02	NE	NE	NE	1.1E+02	NE
PHC F2	NE	NE	8.7E+00	NE	NE	NE	8.7E+00	NE
PHC F3	NE	NE	5.8E+01	NE	NE	NE	5.8E+01	NE
Selenium	2.9E-01	NE	2.0E-01	NE	NE	NE	2.0E-01	1.5E-01
Uranium	9.9E-02	9.2E-02	6.0E-02	NE	3.4E-02	NE	6.0E-02	1.2E-01
Zinc	5.2E-01	NE	1.8E-01	NE	NE	1.3E-01	1.8E-01	1.6E-01

Notes:

Bold – indicates where the estimated SI is greater than one.

NE – Not Evaluated: the particular COPC-receptor combination has been addressed in prior Tier.

**d) Residential Yards** (those COPCs that exceeded in Tier 1)

COPC	American Robin	Cottontail Rabbit	Earthworm	Meadow Vole	Vegetation	Yellow Warbler
Aluminium	NE	NE	<b>4.8E+02</b>	NE	<b>4.8E+02</b>	NE
Arsenic	NE	NE	<b>1.2E+00</b>	NE	<b>1.2E+00</b>	NE
Boron	NE	NE	1.0E+00	NE	1.05E+00	NE
Iron	NE	NE	<b>1.4E+02</b>	NE	<b>1.4E+02</b>	NE
Lead	<b>4.8E+00</b>	NE	NE	NE	NE	<b>3.8E+00</b>
Manganese	NE	NE	<b>1.2E+00</b>	NE	<b>2.5E+00</b>	NE
Zinc	<b>1.2E+00</b>	NE	NE	NE	NE	NE

Notes:

Bold – indicates where the estimated SI is greater than one.

NE – Not Evaluated: the particular COPC-receptor combination has been addressed in prior Tier.

**e) On-Site Groundwater**

ContName	Earthworm (gw)
Chloride	<b>8.4E+00</b>
Fluoride	7.3E-01
Iron	<b>6.3E+01</b>
Manganese	<b>3.1E+00</b>
Selenium	5.3E-01
Sodium	<b>2.9E+02</b>
Zinc	8.6E-01

Notes:

Bold – indicates where the estimated SI is greater than one.

**TIER 2B RESULTS:** (Those COPCs that exceeded in Tier 2a)

Table 6.46 EcoRA – Non-Radiological Risk Results – Terrestrial Receptors (Tier 2b)

**a) On-Site Grass Patches\***

COPC	Earthworm (soil)	Vegetation
Aluminium	<b>9.9E+01</b>	<b>9.9E+01</b>
Arsenic	5.8E-01	5.8E-01
Iron	<b>4.7E+01</b>	<b>4.7E+01</b>
Manganese	7.7E-01	<b>1.6E+00</b>
Potassium	<b>1.4E+02</b>	<b>1.4E+02</b>

Notes:

Bold – indicates where the estimated SI is greater than one.

\*See discussion, Section 6.4.3.2, terrestrial receptors.

**b) On-Site Gravel Areas**

COPCs	Earthworm (soil)
Aluminium	<b>1.0E+02</b>
Chloride	3.0E-02
Iron	<b>6.8E+01</b>
Potassium	<b>5.0E+01</b>

Notes:

Bold – indicates where the estimated SI is greater than one.

**c) Off-Site Grass Strip (those COPCs that exceeded in Tier 2a)**

COPC	American Robin	Earthworm	Vegetation	Yellow Warbler
Aluminium	NE	<b>6.9E+01</b>	<b>6.9E+01</b>	NE
Arsenic	NE	1.0E+00	1.0E+00	NE
Fluoride	1.0E+00	NE	NE	<b>2.6E+00</b>
Iron	NE	<b>4.9E+01</b>	<b>4.9E+01</b>	NE
Lead	<b>1.9E+00</b>	NE	NE	NE
Manganese	NE	NE	9.91E-01	NE
PHC F2	NE	<b>8.7E+00</b>	<b>8.7E+00</b>	NE
PHC F3	NE	<b>3.6E+01</b>	<b>3.6E+01</b>	NE
Potassium	NE	<b>6.1E+01</b>	<b>6.1E+01</b>	NE

Notes:

Bold – indicates where the estimated SI is greater than one.

NE – Not Evaluated: the particular COPC-receptor combination has been addressed in prior Tier.

**d) Residential Yards (those COPCs that exceeded in Tier 2a)**

COPC	American Robin	Earthworm	Vegetation	Yellow Warbler
Aluminium	NE	<b>3.3E+02</b>	<b>3.3E+02</b>	NE
Arsenic	NE	6.2E-01	6.2E-01	NE
Iron	NE	<b>1.1E+02</b>	<b>1.1E+02</b>	NE
Lead	<b>2.4E+00</b>	7.9E-01	7.9E-01	NE
Manganese	NE	9.3E-01	<b>1.9E+00</b>	NE
Zinc	1.0E+00	NE	NE	NE

Notes:

Bold – indicates where the estimated SI is greater than one.

NE – Not Evaluated: the particular COPC-receptor combination has been addressed in prior Tier.

**e) On-Site Groundwater**

ContName	Earthworm (gw)
Chloride	<b>4.2E+00</b>
Iron	<b>3.0E+01</b>
Manganese	9.3E-01
Selenium	7.7E-01
Sodium	<b>1.2E+02</b>

Notes:

Bold – indicates where the estimated SI is greater than one.

**TIER 2C RESULTS:** *(Those COPCs that exceeded in Tier 2b)*

The following contaminants are not carried forward to the Tier 2c assessment as they are not relevant to current PHCF operations:

- Chloride
- Strontium
- Aluminium
- Iron
- Manganese
- Potassium
- Lead
- Barium
- Antimony
- Sodium

With the above contaminants removed from consideration, there are no further exceedances in the on-site grass patches, on-site gravel areas, on-site groundwater or residential yards.

**Table 6.47 EcoRA – Non-Radiological Risk Results – Terrestrial Receptors (Tier 2c)**

**a) On-Site Grass Patches**

No exceedances of any COPCs relevant to PHCF operations.

**b) On-Site Gravel Areas**

No exceedances of any COPCs relevant to PHCF operations.

**c) Off-Site Grass Strip** (those COPCs that exceeded in Tier 2b)

COPC	American Robin	Earthworm	Vegetation	Yellow Warbler
Fluoride	1.0E+00	NE	NE	<b>2.6E+00</b>
PHC F2	NE	<b>8.7E+00</b>	<b>8.7E+00</b>	NE
PHC F3	NE	<b>3.6E+01</b>	<b>3.6E+01</b>	NE

Notes:

**Bold** – indicates where the estimated SI is greater than one.

**NE** – Not Evaluated: the particular COPC-receptor combination has been addressed in prior Tier.

**d) Residential Yards** (those COPCs that exceeded in Tier 2b)

No exceedances of any COPCs relevant to PHCF operations.

**e) On-Site Groundwater**

No exceedances of any COPCs relevant to PHCF operations.

As seen above, a small number of exceedances remain in the off-site grass strip, following the Tier 2c assessment. This is discussed in Section 6.4.3 below

6.4.5.2 Aquatic (Non-Radiological)

Table 6.48 presents the estimated non-radiological risk (SI) results for aquatic receptors, based on their respective environmental media and exposure locations, including:

- A. Harbour; and,
- B. Lake/Beach.

Each of these exposure locations are assessed using the following calculations:

**Tier 1:** estimates are based on maximum concentrations in surface water and sediment.

**Tier 2a:** estimates are based on 95<sup>th</sup> percentile concentrations in surface water and sediment. Tier 2a calculations are limited to those COPCs that exceeded in Tier 1.

**Tier 2b:** estimates are based on 95% UCL concentrations in surface water for mobile receptors, and 95<sup>th</sup> percentile concentrations in surface water for non-mobile receptors (i.e. benthic invertebrates and aquatic vegetation). For mobile receptors in the Harbour exposure location, Tier 2b calculations account for the fraction of time that the receptors spend in the harbour as described in Section 6.2.3; mobile receptors in the lake/beach exposure are not assessed using homerange fractions. Tier 2b calculations are limited to those COPCs that exceeded in Tier 2a.

**Tier 2c:** estimates are based on incremental concentrations in surface water. Tier 2c calculations are limited to those COPCs that exceeded in Tier 2b.



Final – Environmental Risk Assessment for the Cameco Port Hope Conversion Facility

Table 6.48 EcoRA – Non-Radiological Risk Results – Aquatic Receptors (Tier 1)

Exposure Location	COPCs	Aquatic Vegetation	Benthic Fish	Benthic Invertebrates	Horned Grebe	Lesser Scaup	Pelagic Fish
Aquatic Harbour	Aluminium	NC	NC	NC	NC	NC	NC
	Ammonia (as N)	2.1E-01	<b>4.1E+00</b>	<b>4.6E+00</b>	1.7E-04	1.7E-04	<b>1.1E+01</b>
	Arsenic	1.1E-02	2.2E-02	2.2E-02	<b>1.9E+00</b>	<b>1.1E+00</b>	4.3E-03
	Barium	5.6E-04	3.5E-05	1.6E-03	NC	NC	3.3E-04
	Chloride	1.1E-01	2.2E-01	<b>1.1E+00</b>	<b>7.4E+00</b>	<b>7.0E+00</b>	2.1E-01
	Fluoride	3.1E-03	2.2E-02	8.6E-02	3.2E-02	4.9E-02	2.5E-02
	Potassium	4.2E-03	8.5E-03	4.8E-02	NC	NC	NC
	Strontium	1.8E-04	8.5E-02	7.3E-01	NC	NC	<b>3.6E+00</b>
	Uranium	1.4E-03	5.2E-03	2.9E-01	7.5E-02	4.9E-02	1.4E-02
	Zinc	6.9E-02	2.3E-01	7.9E-01	4.2E-02	3.6E-02	5.5E-02
Aquatic Lake/ Beach	Aluminium	NC	NC	NC	NC	NC	NC
	Ammonia (as N)	1.0E-01	<b>2.0E+00</b>	<b>2.3E+00</b>	8.4E-05	8.6E-05	<b>5.3E+00</b>
	Arsenic	5.6E-03	1.1E-02	1.2E-02	1.9E-02	6.7E-03	2.2E-03
	Barium	1.3E-03	8.2E-05	3.7E-03	NC	NC	7.6E-04
	Chloride	2.5E-02	4.9E-02	2.4E-01	<b>1.7E+00</b>	<b>1.5E+00</b>	4.8E-02
	Fluoride	9.4E-04	6.7E-03	2.6E-02	9.5E-03	1.5E-02	7.5E-03
	Potassium	1.5E-03	2.9E-03	1.7E-02	NC	NC	NC
	Strontium	1.8E-04	8.3E-02	7.2E-01	NC	NC	<b>3.6E+00</b>
	Uranium	1.7E-04	6.2E-04	3.5E-02	3.3E-04	5.1E-04	1.7E-03
Zinc	8.6E-03	2.9E-02	9.9E-02	4.2E-03	3.9E-03	6.9E-03	

Table 6.49 EcoRA – Non-Radiological Risk Results – Aquatic Receptors (Tier 2a)

Exposure Location	COPCs	Benthic Fish	Benthic Invertebrates	Horned Grebe	Lesser Scaup	Pelagic Fish
Aquatic Harbour	Ammonia	<b>4.1E+00</b>	<b>4.6E+00</b>	NE	NE	<b>1.1E+01</b>
	Arsenic	NE	NE	4.6E-01	2.7E-01	NE
	Chloride	NE	NE	<b>1.3E+00</b>	<b>1.2E+00</b>	NE
	Strontium	NE	NE	NE	NE	<b>3.6E+00</b>
Aquatic Lake/Beach	Ammonia	<b>1.6E+00</b>	<b>1.8E+00</b>	NE	NE	<b>4.1E+00</b>
	Chloride	NE	NE	<b>1.7E+00</b>	<b>1.5E+00</b>	NE
	Strontium	NE	NE	NE	NE	<b>3.6E+00</b>

Notes:

Bold – indicates where the estimated SI is greater than one.

NE – Not Evaluated: the particular COPC-receptor combination has been addressed in prior Tier.

Table 6.50 EcoRA – Non-Radiological Risk Results – Aquatic Receptors (Tier 2b)

Exposure Location	COPCs	Benthic Fish	Benthic Invertebrates	Horned Grebe	Lesser Scaup	Pelagic Fish
Aquatic Harbour	Ammonia	<b>2.3E+00</b>	<b>2.5E+00</b>	NE	NE	<b>5.8E+00</b>
	Chloride	NE	NE	<b>1.6E+00</b>	<b>1.5E+00</b>	NE
	Strontium	NE	NE	NE	NE	<b>3.5E+00</b>
Aquatic Lake/Beach	Ammonia	<b>1.6E+00</b>	<b>1.8E+00</b>	NE	NE	<b>4.1E+00</b>
	Chloride	NE	NE	<b>1.6E+00</b>	<b>1.5E+00</b>	NE
	Strontium	NE	NE	NE	NE	<b>3.5E+00</b>

Notes:

Bold – indicates where the estimated SI is greater than one.

NE – Not Evaluated: the particular COPC-receptor combination has been addressed in prior Tier.

Table 6.51 EcoRA – Non-Radiological Risk Results – Aquatic Receptors (Tier 2c)

The following contaminants are not carried forward to the Tier 2c assessment as they are not relevant to current PHCF operations:

- Chloride
- Strontium

Exposure Location	COPCs	Benthic Fish	Benthic Invertebrates	Horned Grebe	Lesser Scaup	Pelagic Fish
Aquatic Harbour	Ammonia	3.2E-01	3.6E-01	NE	NE	8.3E-01
Aquatic Lake/Beach	Ammonia	2.8E-02	3.2E-02	NE	NE	7.3E-02

Notes:

NE – Not Evaluated: the particular COPC-receptor combination has been addressed in prior Tier.

As seen in the table above, no PHCF-related exceedances remain after the Tier 2c assessment.

## 6.4.6 Summary and Discussion of Results

### 6.4.6.1 Radiological

#### Terrestrial:

As shown in Section 6.4.1.1, no screening index results were found to have values greater than 1, and therefore, the estimated radiological doses to terrestrial receptors are less than the corresponding benchmarks. No undue radiological effects are anticipated.

#### Aquatic:

As shown in Section 6.4.1.2, no screening index results were found to have values greater than 1, and therefore, the estimated radiological doses to aquatic receptors are less than the corresponding benchmarks. No undue radiological effects are anticipated.

### 6.4.6.2 Non-Radiological

#### Terrestrial:

Tier 1 calculations, based on maximum COPC concentrations in environmental media, identified the following COPCs with risk results that exceed their corresponding benchmark values for one or more ecological receptors:

- **Soil (On-site Grass Patches):**
  - Aluminum;
  - Arsenic;
  - Iron;
  - Manganese; and
  - Potassium.
- **Soil (On-site Gravel Areas):**
  - Aluminum;
  - Arsenic;
  - Cobalt;
  - Copper;
  - Iron;
  - Manganese;

- Nickel; and
- Potassium.
- **Soil (Off-site Grass Strip):**
  - Aluminum;
  - Arsenic;
  - Boron;
  - Cobalt;
  - Copper;
  - Fluoride;
  - Iron;
  - Lead;
  - Manganese;
  - Nickel;
  - PHC F2;
  - PHC F3;
  - Potassium;
  - Selenium;
  - Uranium; and
  - Zinc.
- **Soil (Residential Yard):**
  - Aluminum;
  - Arsenic;
  - Boron;
  - Iron;
  - Lead;
  - Manganese; and
  - Zinc
- **Groundwater (for perspective):**
  - Chloride;
  - Fluoride;

- Iron;
- Manganese;
- Selenium;
- Sodium;
- Uranium; and
- Zinc.

Having exceeded their respective benchmarks in Tier 1 calculations, these COPCs underwent further evaluation using Tier 2a calculations, based on 95<sup>th</sup> percentile concentrations in environmental media. Tier 2a calculations identified the following COPCs with results that exceed their corresponding benchmarks for one or more terrestrial receptors:

- **Soil (On-site Grass Patches):**

- Aluminum;
- Arsenic;
- Iron;
- Manganese; and
- Potassium.

- **Soil (On-site Gravel Areas):**

- Aluminum;
- Iron; and
- Potassium.

- **Soil (Off-site Grass Strip):**

- Aluminum;
- Arsenic;
- Fluoride;
- Iron;
- Lead;
- Manganese;
- Potassium;
- PHC F2; and
- PHC F3.

- **Soil (Residential Yard):**

- Aluminium;
- Arsenic;
- Iron;

- Lead;
- Manganese; and
- Zinc.
- **Groundwater (for perspective):**
  - Chloride;
  - Iron;
  - Manganese;
  - Selenium; and
  - Sodium.

Having exceeded their respective benchmarks in Tier 2a calculations, these COPCs underwent further evaluation using Tier 2b calculations. For all receptors, Tier 2b calculations are based on soil concentrations in the top 0.5 mbgs soil layer as described in 6.4.2.1. For mobile receptors, Tier 2b calculations are based on 95% UCLM concentrations in environmental media. For non-mobile receptors (i.e. vegetation and soil invertebrates) Tier 2b calculations continue to use 95<sup>th</sup> percentile concentrations in soil. For arsenic, Tier 2b calculations also utilize leach test results from the SENES (2009) SWRA for the grass strip. Overall, Tier 2b calculations identified the following receptor-COPC combinations to exceed their corresponding criteria:

- **Soil (On-site Grass Patches):**
  - Aluminium (earthworm, vegetation);
  - Iron earthworm, vegetation);
  - Manganese (vegetation);
  - Potassium (earthworm, vegetation).
- **Soil (On-site Gravel Areas, earthworm only):**
  - Aluminium;
  - Iron;
  - Potassium.
- **Soil (Off-site Grass Strip):**
  - Aluminum (earthworm, vegetation);
  - Fluoride (American robin and yellow warbler);
  - Iron (earthworm, vegetation);
  - Lead (American robin);
  - PHC F2 (earthworm, vegetation);
  - PHC F3 (earthworm, vegetation);
  - Potassium (earthworm, vegetation).

- **Soil (Residential Yards):**
  - Aluminium (earthworm and vegetation);
  - Iron (earthworm and vegetation);
  - Manganese (vegetation).
- **Groundwater (earthworm, illustrative only):**
  - Chloride
  - Iron;
  - Sodium.

For the on-site grass patch exposure locations, Tier 2b results show exceedances of aluminium, iron and potassium for earthworms and vegetation; and exceedances of manganese for earthworms. As these COPCs are not associated with current Cameco PHCF operations these contaminants have not been carried forward to the Tier 2c assessment. Furthermore, the on-site grass patch environment is poor habitat for ecological receptors, and the risk of potential effects does not extend to the surrounding areas such as nearby residential lands; population-level effects (within the overall Port Hope area) are not expected. No exceedances of COPCs associated with current Cameco PHCF operations are expected at the on-site grass patch exposure locations.

For the on-site gravel exposure location, Tier 2b results show exceedances of aluminium, iron and potassium for earthworms. Because these COPCs are not associated with current Cameco PHCF operations these contaminants have not been carried forward to the Tier 2c assessment. Furthermore, these locations offer poor and largely unsuitable habitat for ecological receptors. As described in the SENES (2009a,b) studies, the on-site gravel areas include for example, transportation routes for personnel and equipment, outdoor storage, and other industrial uses. An example of one particular gravel area is shown in Figure 6.4. As described in the SENES (2009a,b) studies, gravel areas also experience significant soil compaction which further reduces their potential as habitat. Ultimately, the risk of potential effects does not extend to the surrounding areas such as nearby residential lands, and population-level effects (within the overall Port Hope area) are not expected.

For the off-site grass strip location, the Tier 2b assessment show exceedances of lead, iron, potassium, fluoride, PHC F2 and PHC F3. Because lead, iron and potassium are not associated with current Cameco PHCF operations these contaminants have not been carried forward to the Tier 2c assessment. Fluoride, PHC F2 and PHC F3 were carried forward to the Tier 2c assessment, discussed below.

For the residential yard locations, the Tier 2b assessment show exceedances of aluminium and iron for earthworms and vegetation and manganese for vegetation. As these COPCs are not associated with current Cameco PHCF operations these contaminants have not been carried forward to the Tier 2c assessment. No exceedances of COPCs associated with current Cameco PHCF operations are expected at the residential yard locations.

Figure 6.4. Example On-Site Gravel Areas





Following the Tier 2c assessment, including removal of COPCs that are not associated with current PHCF operations, the following exceedances remain, all in the off-site grass strip:

- Fluoride: American robin, yellow warbler;
- PHC F2: Earthworm and vegetation; and
- PHC F3: Earthworm and vegetation.

The fluoride, PHC F2 and PHC F3 results are based on soil samples taken in the grass patches along the Harbour wall and along the north end of the Site. Due to its limited area, narrow shape and industrial location, the grass strip is not likely a suitable habitat for large numbers of ecological species. There are not expected to be population-level effects that impact the overall Port Hope area. This area will be remediated as part of the VIM and/or PHAI projects within the next licence period.

Aquatic:

Tier 1 calculations, based on maximum COPC concentrations in environmental media, identified the following COPCs with risk results that exceed their corresponding benchmark values for one or more aquatic receptors:

- **Surface Water (Harbour):**
  - Ammonia;
  - Arsenic;
  - Chloride;
  - Strontium.
- **Surface Water (Lake/Beach):**
  - Ammonia;
  - Chloride;
  - Strontium.

Having exceeded their respective benchmarks in Tier 1 calculations these COPCs underwent further evaluation using Tier 2a calculations, based on 95<sup>th</sup> percentile concentrations in environmental media. Tier 2a calculations identified the following COPCs with risk results that exceed their corresponding benchmarks for one or more aquatic receptors:

- **Surface Water (Harbour):**
  - Ammonia;
  - Chloride;
  - Strontium.
- **Surface Water (Lake/Beach):**
  - Ammonia;

- Chloride;
- Strontium.

Having exceeded their respective benchmarks in Tier 2a calculations these COPCs underwent further evaluation using Tier 2b calculations which are typically based on 95% UCLM concentrations in environmental media; however, the surface water data do not allow for calculating a statistically robust total ammonia 95% UCL, and therefore the 95<sup>th</sup> percentile continued to be used. For the Harbour exposure location, Tier 2b calculations account for the fraction of time that fish species reside within the harbour exposure location, as discussed in Section 6.2.3 (residency fraction not used for Lake/Beach exposure location). Tier 2b calculations identified the following COPCs with risk results that exceed their corresponding benchmarks for one or more aquatic receptors:

- **Surface Water (Harbour):**
  - Ammonia (benthic fish, benthic invertebrates, pelagic fish);
  - Chloride (lesser scaup);
  - Strontium (pelagic fish).
- **Surface Water (Lake/Beach):**
  - Ammonia (benthic fish, benthic invertebrates, pelagic fish);
  - Chloride (lesser scaup, horned grebe);
  - Strontium (pelagic fish).

Overall, Tier 2b calculations identified potential exceedances of ammonia, chloride and strontium at the Harbour and/or lake locations. Both chloride and strontium are not associated with current Cameco PHCF operations and therefore were not evaluated in the Tier 2c assessment. Ammonia was carried forward to the Tier 2c assessment, discussed below. The previous SENES (2009a) SWRA also identified strontium as exceeding its benchmarks for pelagic fish. In response to these findings, additional field surveys and surface water toxicity tests (using benthic organisms and rainbow – a pelagic fish species) were completed in the 2009 SWRA. Toxicity testing involved the investigation of acute, sub-chronic, and chronic impairment. Toxicity test results indicated that no samples were found to cause undue impairment. The reader is referred to the original SENES (2009a) study for the results of these supplementary investigations.

For the harbour and lake/beach locations Tier 2c assessment, ammonia was evaluated using incremental surface water concentrations. The assessment determined no exceedances of the benchmark values. Therefore, based on the results of the Tier 2c assessment, no undue risks are expected for aquatic biota from COPCs associated with current Cameco PHCF operations.

## 6.5 Uncertainties in the EcoRA

- **Problem Formulation and Ecological Conceptual Site Model:** As discussed earlier, the objective and scope of the ERA are set out clearly as the assessment of potential effects from current emissions associated with facility operations. Therefore, the uncertainty associated with sources

of contamination (site vs. off-site fill materials), historical vs. current contamination, etc., do not apply to the EcoRA. However, there is not uncertainty in the ERA scope: The EcoRA focuses on receptors and pathways relevant to current operations, and where possible, evaluates risk associated with current operations (i.e., the 'incremental' cases). The CSM developed for the HHRA is clear on what pathways were included in the assessment. *Degree of uncertainty: Low.*

- Receptor Selection and Characterization: Receptors were selected to be consistent with previous studies, and include consideration of Species at Risk. Although taken from reliable references (including Environment Canada guidance), there is uncertainty associated with many of the receptor characteristics values used. For example, soil and sediment ingestion rates for some biota were derived using allometric equations. In addition, assumptions were required in order to estimate home ranges, exposure durations and dietary component fractions. Where possible, conservative assumptions were made for these parameters. It is noted that some of the receptor characteristic parameters are obtained from studies involving animals in captivity, and therefore may not be fully representative of free-range animals in the wild. An underestimate of exposure might result from this – for example, by assuming a body weight that is greater than for animals in the wild - but there are other conservative assumptions that may compensate (e.g. assuming 100% of intake of a COPC is absorbed by the body). *Degree of uncertainty: Medium.*
- Secondary COPC screening: MOE component values specific to EcoRA were used in the secondary soil and groundwater screening. As discussed earlier, the screening methodology was set up to minimize uncertainty: maximum measured concentrations were used, in the absence of screening criteria (or other appropriate comparison values), contaminants were 'screened-in', i.e., retained as COPCs. This conservative approach resulted in a long list of COPCs. *Degree of uncertainty: Low.*
- Exposure Point Concentrations: Measured concentrations of COPCs, and measured activities of radionuclides, were used wherever such data was available. For non-radiological COPCs, the HHRA uses the maximum and 95% UCLM concentrations from throughout the year. The use of these concentrations assumes that receptors are exposed to these higher concentrations year-round, when in reality, there are both spatial and temporal variations in concentrations. Several of the ecological receptors have large home ranges, and the location of a maximum concentration might represent only a small portion of their overall range. Thus, exposures are likely overestimated in the assessment. *Degree of Uncertainty: Low.*
- Exposure Assessment: The models and equations used to estimate risk to biota were based on guidance from CSA N288.6. The use of this vetted methodology is expected to reduce the potential error and/or uncertainty in the calculations. With respect to the parameters used to carry out the calculations (e.g., transfer factors and dose coefficients), the hierarchy of reference sources provided in CSA N288.6 was followed. If not available in the recommended documents, parameter values from other literature sources were selected, or assumptions were made, with conservatism in mind (e.g., earthworm concentration was set equal to soil concentration). In the estimate of gamma dose to biota, the maximum measured gamma (i.e., the location of highest gamma reading in 2014) was applied to all receptors, at all locations, assuming 100% residence time. The assessment of radon dose for burrowing animals applied the radon contribution to the entire

estimated dose of Ra-226, which assumes that the receptor spends all of its time burrowed. Both of these assumptions result in very conservative estimates. *Degree of uncertainty: Low.*

- In order to minimize human calculation error, internally-reviewed relational database models were used to calculate exposure, dose and risk in the EcoRA. *Degree of uncertainty: Low.*
- Toxicity Assessment: As discussed in CSA N288.6, there is inherent uncertainty in the use of TRVs; however, the TRVs used were selected using a hierarchy of recent, credible sources, which include but are not limited to those recommended in CSA N288.6. These sources have already applied uncertainty factors to their TRVs. Therefore, while the inherent uncertainty in the TRVs cannot be removed, it has been controlled to the extent possible. If there was too much uncertainty in a TRV, it was not used. For example, there was no avian barium TRV available in the main literature references (Eco-SSL or Sample *et al.* 1996). Due to the large uncertainty associated with using a mammalian surrogate, a TRV was not developed for barium in aquatic birds. It is also noted that toxicity information for a COPC was used regardless of its form in the test procedure, even though this may not be the same form used in the assessment (e.g., an oxide form compared to a more soluble form). It is difficult to determine the effect of these assumptions. *Degree of uncertainty: Medium.*
- Risk Estimation: The risk estimation reflects the uncertainties identified in the exposure assessment and toxicity assessment. This ERA did not include an assessment of multi-stressor effects, including interactions between contaminants, or between physical and chemical stressors. When dealing with toxic chemicals, there is potential interaction with other chemicals that may be found at the same location. It is well established that synergism, potentiation, antagonism or additivity of toxic effects occurs in the environment. A detailed quantitative assessment of these interactions is beyond the scope of the present study, and, for many COPC-receptor combinations there is not an adequate base of toxicological evidence to examine these interactions. This may result in an underestimate of the risk for some COPC combinations. *Degree of uncertainty: Medium.*

Table 6.52 outlines some of the uncertainties identified in the EcoRA and how in general, they have been overcome by using conservative assumptions that are likely to lead to an over-estimate of exposures (and therefore no change in the conclusions).

Table 6.52 EcoRA – Summary of Uncertainties

Uncertainty	Likely Leads to Overestimate	Possibly Leads to Underestimate	Neither Overestimate or Underestimate
Use of maximum or 95% UCL concentrations to characterize exposures	X		
Estimation of radionuclide activity concentrations for those radionuclides without measured data (i.e. use of specific activity and secular equilibrium, based on maximum	X		
Use of transfer factors to estimate tissue concentrations	X		
Use of exposure characteristics from literature for ecological receptors			X
Neglecting migratory behaviour, and home range fraction (i.e., assuming <i>all</i> ingested food, water, and soil is from within the study area)	X		
Use of laboratory-derived TRVs for chronic exposure and effects	X		
Synergism, potentiation, antagonism, additivity of toxic effects		X	

## 7 ASSESSMENT OF PHYSICAL STRESSORS

### 7.1 Fish Entrainment Assessment

#### 7.1.1 Introduction & Overview

Impingement occurs when fish come in contact with a screen or a trash rack at a water intake, while entrainment occurs when fish (including eggs) are drawn into the intake and subjected to mechanical equipment, heat and chemicals resulting in indirect or direct mortality. Impingement and entrainment losses can have the most significant impact on the fisheries community at water intakes. Fisheries and Oceans Canada (DFO) guideline documents exist for fish protection at water intakes for cooling water purposes. Guidelines are available on the design of screens for small intakes ( $\leq 0.125 \text{ m}^3/\text{s}$ ) (Freshwater Intake End-of-Pipe Guideline, DFO 1995). However, the intake structure at the Cameco PHCF exceeds  $0.125 \text{ m}^3/\text{s}$  and there is therefore a need to develop a detailed guidance for these larger intakes and mitigation strategies to avoid fish losses through Impingement and Entrainment (I&E). In 2012, SENES was contracted by DFO to develop recommendations for fish protection guidelines for medium and large intake structures which exceed  $0.125 \text{ m}^3/\text{s}$ , and a draft report has been prepared (SENES and 4DM 2013). Monitoring protocols for estimating I&E were also recommended and are summarized in SENES (2013a).

Baseline impingement sampling was conducted between October 17 and December 18, 2012, and April 23 and July 11, 2013 at the PHCF to determine baseline levels (SENES 2013a, SENES 2013b). Overall estimated impingement numbers and rates for spring/summer 2013 were considered low, and video observation of the intake screens showed fish freely swimming across the screens, illustrating how the intake velocities at the PHCF were not impinging fish. Based on these results, no additional impingement mitigation or further impingement sampling was recommended (SENES 2013a).

Baseline entrainment sampling was conducted between June 20 and July 11, 2013. While the resultant entrainment rates were considered low, the entrainment sampling campaign was limited to a summer time period. It was therefore recommended that additional entrainment sampling be conducted during the spring and summer of 2014 to provide a more complete picture of the species and numbers entrained during the spring (SENES 2013a).

#### 7.1.2 Objectives

SENES conducted additional entrainment sampling to determine baseline levels in the spring and summer (April through July) of 2014 (SENES 2014a). The following tasks were completed as part of entrainment sampling:

1. Collection, processing and identification of fish larvae and eggs from entrainment samples collected over two, 12 hour periods for each sampling event.
2. Collection, processing and identification of incidental juvenile and adult fish and other animals collected during the entrainment sampling. These collections do not represent “true” entrainment since the collection apparatus was placed in front of traveling screens.

### 7.1.3 Methodology

#### 7.1.3.1 Sampling

Entrainment sampling was conducted following the methodology used during the 2013 sampling program (SENES 2013a). In brief, water from the intake channel was pumped out of the channel using a centrifugal pump and then pumped back into the intake channel through a plankton net in order to capture fish eggs and larvae in the water. Details on the equipment are provided elsewhere (SENES 2013a). The flow rate of the pump was tested regularly in order to accurately calculate the total volume of water sampled. For each test, the flow rate was measured three times and the rates averaged to determine the average volume pumped per hour (m<sup>3</sup>/hr). These rates were then used to calculate the estimated entrainment rates for each species of larvae and eggs collected in the samples.

Entrainment monitoring started on March 31, 2014, after which sampling occurred over three days almost weekly until July 9, 2014. Sampling did not occur the weeks of June 1-7, due to some logistical constraints, or the week of June 22-28, as the plant was in shut-down and not drawing harbour water. For each week, two, 12-hour, day time samples (approximately 06:00 to 18:00); and two, 12-hour, night time samples (approximately 18:00 to 06:00) were collected. A total of 52 samples were collected over 13 weeks with increased sampling during the spring (expected key entrainment period). All collected eggs were examined with a dissection scope to determine if the eggs were fertilized or unfertilized. Signs of fertilized eggs include cell division, presence of embryonic fish structures, and decreased buoyancy.

#### 7.1.3.2 Overall Estimates

Entrainment counts for the day and night periods were summed for each week and then divided by the total sample volume for that week to obtain a weekly day time and night time entrainment rate for each species. These rates were then multiplied by half of the total intake volume for the week (to represent either the day time or night time period), to obtain an estimate of the total number of organisms entrained that week (Equation 7-1).

$$Edw = \left( \frac{Cdw}{SVdw} \right) \times \left( \frac{DIVw}{2} \right) \quad (7-1)$$

Where:

- Edw = Weekly entrainment estimate, daytime period
- Cdw = Weekly count of entrained organisms, daytime period
- SVdw = Total water volume sampled during week, daytime period
- DIVw = Total Daily Intake Volumes for week

### 7.1.3.3 Incidental Fish Collections

Any adult or juvenile fish collected during entrainment sampling were identified, measured, and its condition (live, recently dead, long dead) determined. Fish condition is a measure of when the fish died, with 'long dead' fish considered to have died prior to sampling. The condition of impinged organisms was assessed using a modification of the criteria developed by White (1986). Any other animals collected were also recorded. When possible, healthy adult fish or other animals were released live back into the harbour.

### 7.1.4 Results

Fish eggs or larvae were only collected in a total of 4 samples during the sampling program, and all fish eggs were either unfertilized or were just membrane fragments and not entire eggs. Only two larvae were collected, occurring in the July 1-2 night sample; however, the larvae were long dead (>24 hrs dead) and badly degraded. The egg species included Round Goby, Alewife and Rainbow Smelt while the larvae were most likely of the Cyprinidae family.

Overall entrainment estimates are presented in Table 7.1 (larvae) and Table 7.2 (eggs). Based on volume calculations, an estimated 4,317 eggs and 131 larvae were entrained at PHCF between March 30 and July 12, 2014.

Juvenile and adult fish were also collected during sampling (Table 7.3). Twelve different species were collected, none of which are considered species at risk provincially or federally. Three other animal species were collected in the entrainment samples besides fish. The most abundant were crayfish (44 individuals), with a single juvenile Snapping Turtle (*Chelydra serpentina*) and a tadpole also collected. Snapping Turtles are a Species at Risk listed as Special Concern federally and provincially. The majority of the incidental catch occurred in April and May, and many of these incidental catch organisms were too large to pass through the intake screens. During the last week of June it was discovered that their presence was likely due primarily to a breach along the north side of the intake structure as a result of sediment erosion. A high number of mussels were also found in the intake screen panel slots, such that the intake screens were not fitting into place tightly. In the two weeks of sampling following repair and cleaning to remedy these problems, only a single tiny fish was collected in the entrainment samples.



Final – Environmental Risk Assessment for the Cameco Port Hope Conversion Facility

Table 7.1 Estimated Entrainment of Fish Larvae

Period	Day			Night			Total Estimated Entrained Organisms
	Organism	Overall Entrainment Rate (#/1000 m <sup>3</sup> )	Estimated Entrainment (# organisms)	Organism	Overall Entrainment Rate (#/1000 m <sup>3</sup> )	Estimated Entrainment (# organisms)	
March 30-April 5	None	0	0	None	0	0	0
April 6-12	None	0	0	None	0	0	0
April 13-19	None	0	0	None	0	0	0
April 20-26	None	0	0	None	0	0	0
April 27 – May 3	None	0	0	None	0	0	0
May 4-10	None	0	0	None	0	0	0
May 11-17	None	0	0	None	0	0	0
May 18-24	None	0	0	None	0	0	0
May 25-31	None	0	0	None	0	0	0
June 1-7*	None	0*	0	None	0*	0	0
June 8-14	None	0	0	None	0	0	0
June 15-21	None	0	0	None	0	0	0
June 22-28	None	0	0	None	0	0	0
June 29 – July 5	None	0	0	Cyprinidae sp.	3.04	131	131
July 6-12	None	0	0	None	0	0	0
		<b>Total</b>	<b>0</b>		<b>Total</b>	<b>131</b>	<b>131</b>

\* Entrainment rate inferred by averaging entrainment collections from the weeks of May 25-31 and June 8-14.

Final – Environmental Risk Assessment for the Cameco Port Hope Conversion Facility

Table 7.2 Estimated Entrainment of Fish Eggs

Period	Day			Night			Total Estimated Entrained Organisms
	Organism	Overall Entrainment Rate (#/1000 m <sup>3</sup> )	Estimated Entrainment (# organisms)	Organism	Overall Entrainment Rate (#/1000 m <sup>3</sup> )	Estimated Entrainment (# organisms)	
March 30-April 5	None	0	0	None	0	0	0
April 6-12	None	0	0	None	0	0	0
April 13-19	None	0	0	None	0	0	0
April 20-26	None	0	0	None	0	0	0
April 27 – May 3	None	0	0	None	0	0	0
May 4-10	None	0	0	None	0	0	0
May 11-17	None	0	0	None	0	0	0
May 18-24	Round Goby	7.69	386	Rainbow Smelt	70.67	3548	3934
May 25-31	None	0	0	None	0	0	0
June 1-7*	None	0*	0	Alewife	3.08*	127	127
June 8-14	None	0	0	Alewife	6.17	256	256
June 15-21	None	0	0	None	0	0	0
June 22-28	None	0	0	None	0	0	0
June 29 – July 5	None	0	0	None	0	0	0
July 6-12	None	0	0	None	0	0	0
		<b>Total</b>	<b>386</b>		<b>Total</b>	<b>3931</b>	<b>4317</b>

\* Entrainment rate inferred by averaging entrainment collections from the weeks of May 25-31 and June 8-14.

Final – Environmental Risk Assessment for the Cameco Port Hope Conversion Facility

Table 7.3 Summary of Incidental Catch During Entrainment Sampling

Common Name	Scientific Name	April					May					June				July	Total
		A	A/J	J	U	Total	A	A/J	J	U	Total	A	A/J	J	Total	J	
<b>Fish</b>																	<b>206</b>
Alewife	<i>Alosa pseudoharengus</i>						3		1		4	1	1	1	3		7
Brook Stickleback	<i>Culaea inconstans</i>	10	4	3		17											17
Brown Bullhead	<i>Ameiurus nebulosus</i>	1				1											1
Chinook Salmon	<i>Oncorhynchus tshawytscha</i>			2		2											2
Pumpkinseed	<i>Lepomis gibbosus</i>			3		3			2		2						5
Rainbow Trout	<i>Oncorhynchus mykiss</i>	1		13		14			12		12						26
Rock Bass	<i>Ambloplites rupestris</i>			1		1	1				1						2
Round Goby	<i>Neogobius melanostomus</i>	9	1	8		18	37	18	15		70	5	1	8	14	1	103
Spottail Shiner	<i>Notropis hudsonius</i>			1		1											1
Three-Spined Stickleback	<i>Gasterosteus aculeatus</i>													1	1		1
White Sucker	<i>Catostomus commersonii</i>			17		17											17
Yellow Perch	<i>Perca flavescens</i>	2		8		10			4		4						14
<b>Other Animals</b>																	<b>46</b>
Crayfish sp(p).		9		1	9	19	5		3	3	11	5		9	14		44
Snapping Turtle	<i>Chelydra serpentina</i>			1		1											1
Frog sp.				1		1											1
	<b>Total</b>	<b>32</b>	<b>5</b>	<b>59</b>	<b>9</b>	<b>107</b>	<b>46</b>	<b>18</b>	<b>37</b>	<b>3</b>	<b>104</b>	<b>11</b>	<b>2</b>	<b>19</b>	<b>33</b>	<b>1</b>	<b>252</b>

A, Adult; A/J, within 5 mm of lower end of the adult size range for the species; J, Juvenile; U, Unknown.

### 7.1.5 Conclusions

Entrainment samples collected in the spring and summer of 2014 (March-July) indicated few species and relatively low abundances, especially when compared to annual entrainment estimates from other power plants on the Great Lakes. Additionally, as all the eggs collected were unfertilized, if they had not been entrained, they would not have produced fish and, therefore, were of no value to the local fish population. Even if the entrained eggs had been fertilized, and the larvae were alive when collected, the entrainment numbers are so low that entrainment at PHCF is likely having a negligible effect on local fish populations.

The spring and summer 2014 results were similar to the summer 2013 results (SENES 2013a), consistent with earlier impingement results showing low numbers impinged (SENES 2013b). Entrainment consisted primarily of unfertilized Rainbow Smelt eggs, with a lesser abundance of Round Goby and Alewife eggs. Cyprinidae were the only larvae collected. As these low abundances occurred in spite of a breach in the intake structure, this is a good indication that overall entrainment potential at PHCF is low.

## 7.2 Fish Thermal Effects Assessments

### 7.2.1 Introduction & Overview of Studies

Cameco currently uses Lake Ontario water from the Port Hope harbour for cooling purposes at its PHCF. The water is taken from the entrance of the channel, i.e., where the channel meets the near-shore Lake Ontario and the mouth of the Ganaraska River. The on-cethrough non-contact cooling water is circulated through the two PHCF operating plants, the uranium dioxide (UO<sub>2</sub>) and uranium hexafluoride (UF<sub>6</sub>) plants, and subsequently discharged to the harbour at two outfall locations (UO<sub>2</sub>N, on the west side of the Turning Basin and UO<sub>2</sub>S, pm west side of the Channel).

The following series of investigations have been carried out in recent years to investigate thermal impacts on aquatic biota (fish and benthic invertebrates) in the harbour and in the area downstream of the harbour:

- *Cameco Port Hope Conversion Facility Thermal Plume Effects Study*, prepared by SENES Consultants Limited for Cameco Corporation, March 2012 (SENES 2012a);
- *Thermal Effects Risk Assessment for Port Hope Conversion Facility*, prepared by SENES Consultants for Cameco Corporation, July 2013 (SENES 2013c); and
- *Port Hope Conversion Facility Thermal Risk Assessment Follow Up*, prepared by SENES Consultants for Cameco Corporation, September 2014 (SENES 2014b).

A brief overview of the objectives, methodologies, results and key conclusions from each of these three studies are discussed in this section while further details can be found in the original reports.

## 7.2.2 Thermal Plume Effects Study (SENES 2012a)

### 7.2.2.1 Objectives

The *PHCF Thermal Plume Effects Study* (SENES 2012a) was conducted to understand and assess the thermal impacts of the discharges on the aquatic environment of the receiving waters (the Turning Basin, the Channel, and outside the harbour). The study was carried out in support of a Certificate of Approval (CofA) amendment in that it investigated if there was a risk-based rationale for modifying the temperature requirements, developed a strategy for a CofA amendment application and recommended effluent temperatures ( $\Delta T$  and maximum effluent temperature).

### 7.2.2.2 Methodology

The daily average, monthly average and maximum weekly average temperature (MWAT) were calculated from historical data at each of the following locations: the two outfalls (UO<sub>2</sub>N and UO<sub>2</sub>S), the intake, the Ganaraska River and Lake Ontario.

Thermal modelling was carried out to better understand the effects of temperature on the aquatic environment. More specifically, modelling was used to simulate the geometry (shape and size) of the plume of water heated by discharges from the two outfalls in the harbour. Two scenarios were developed in order to simulate the temperature in the harbour following the discharge of cooling water from the PHCF. Scenario 1 simulated the thermal plume during the month of January (month of observed maximum change in temperature between intake and discharge water), while Scenario 2 simulated the thermal plume for the month of August (month of observed maximum daily temperature of discharge water). Thermal plume modelling was completed using a two-stage approach. First, near-field plume geometry (width, depth, flow and temperature change between inlet and outlet) was calculated for two different discharge water temperatures (maximum daily and monthly average) using CORMIX to account for near-field mixing. Second, far-field modelling using the thermal plume flow and temperature change from the first step was completed using ECOMSED to estimate the dilution and extent of thermal discharge in the harbour.

Ambient flow and temperature in the harbour were derived using ECOMSED assuming (i) real-time cooling water discharge into the harbour (for input into CORMIX) and (ii) no cooling water discharge into the harbour (to calculate the temperature change in the harbour as a result of the cooling water discharge).

Verification of the modelling results was carried out by comparing the predicted temperatures to observed temperature data.

Based on previous studies and knowledge of the site and surrounding aquatic environments, a list of indicator fish and benthic invertebrate species was developed to include representatives from near-shore, harbour and watercourse communities. A literature search was then conducted in order to obtain thermal effects benchmarks for the indicator species, and to complete a comparison of field-based benchmarks versus corresponding laboratory-based benchmarks to aid in the selection of representative benchmarks for benthic invertebrates and fish for the risk assessment.

Measured and modelled water temperatures in the harbour and downstream of the harbour, in combination with the thermal effects benchmarks, were used to estimate the effects of temperature on various species of benthic invertebrates and fish at various life stages for short- and long-term exposure. When applicable,

season- and location-specific temperature data sets were used (e.g., spring data to assess effects on fish that spawn in the spring). Hazard quotient (HQ) values were calculated for long- and short-term exposure using the CORMIX-modelled MWAT and 24-hr maximum temperatures, respectively. For fish, avoidance and habitat loss (long-term exposure) HQ values were also calculated. For fish, thermal effects calculations were completed for the 19 indicator fish species; each with 5 life stages; at each of the 4 locations; for all applicable depth ranges. For benthics, the calculations were completed for 11 benthic species; at each of the 4 locations; at a depth range of 1 m above lake bottom. Short-term thermal effects calculations were also completed for species with available short-term benchmarks at ten locations using measured temperature data from August 2011.

Field studies were also conducted to determine if thermal effects of the discharge of PHCF cooling water are in fact occurring and potentially impacting the development and growth rate of benthic invertebrates in the Port Hope harbour and downstream. This was evaluated through the measurement of chironomid head capsule size for selected chironomid species in the harbour, and through comparison of species diversity, relative abundance and other biological metrics of macroinvertebrates in sites near the area of discharge versus control locations in Lake Ontario and the Ganaraska River.

### 7.2.2.3 Results

The daily delta temperature in the harbour (difference between the daily and ambient temperatures in the harbour) in both the Turning Basin and the Channel exceeded the limit of 3°C near the bottom in January 2011 and near the surface in August 2011.

No potential risks were identified for any of the fish using the January 2011 modelled temperatures. Using the August 2011 modelled temperatures, some potential risk was identified for a number of fish species. It should be noted that the risk calculations did not take into account residence time of fish; it was assumed that the assessed fish spend all of their time (i.e., in the period being studied) in the Port Hope Harbour, which is a conservative assumption given the known biology and behaviour in Lake Ontario. It was recommended that future studies consider more detailed fisheries assessments to better define fish residency in the Port Hope Harbour and surrounding areas.

Overall, over 2,000 HQ calculations were completed for fish, 39 of which were greater than the acceptable value of 1.0. These were all calculated for the month of August, which is typically the hottest month of the year. The risk assessment based on measured August 2011 data also identified some potential risk to several fish species. Fish residency in the harbour was assumed for the entire time period studied for both the modelled and measured assessments, which is conservative. When comparing the results for measured and modelled data, the modelled results appeared to provide an overly conservative assessment of effects (i.e., higher HQ values).

The risk assessment identified no potential risk to benthic invertebrates from exposure to the thermal plume. Due to the general low availability of benthos thermal benchmarks values in literature, a large number of calculations could not be completed. Again, the HQ values from the modelled temperature data were higher (more conservative) than those calculated from the measured data, but all of the values were still below the acceptable value of 1.0.

Results of the field study indicated that there are likely no thermal effects on the development and growth rate of benthic invertebrates due to the discharge of cooling water from the PHCF.

#### 7.2.2.4 Objectives

### 7.2.3 Thermal Effects Risk Assessment (SENES 2013c)

The *Thermal Effects Risk Assessment for Port Hope Conversion Facility* (SENES 2013c) was carried out for fish in the thermal plume of the PHCF, based on surface and mid-depth temperature measurements from June to December, 2012. A dynamic 3-D hydrodynamic model that simulates the currents and water temperature conditions along the north shore of Lake Ontario was also developed and calibrated in order to assess the impacts on the water temperature at selected locations in the vicinity of the plant discharges.

Based on the results of the 2012 study, it was recommended that future studies consider more detailed fisheries assessments to better define fish residency in the Port Hope Harbour and surrounding areas. As such, the risk assessment also involved a fish community assessment in June and October 2012 and a fish residency study focused on salmonids in October and November 2012. *In situ* egg incubation trials were also carried out in order to study the effects of increased temperatures on the development and hatching success of the Chinook salmon.

#### 7.2.3.1 Methodology

Temperature measurements were available at locations within the turning basin and the approach channel as well as in two lake background locations (Lake Ontario east and west of the PHCF) at surface and mid-depth. The thermal plume was modelled using the MIKE-3 package from the Danish Hydraulic Institute. Details on the model inputs and development can be found in Section 3.0 of the risk assessment report (SENES 2013c). The model was verified by comparing to measured temperatures. Correlation values of 0.8 for surface and 0.7 for mid-depth were obtained. The model was then used to estimate temperatures at additional locations (i.e., by interpolation) and under various operating conditions (e.g., with and without thermal discharge).

The risk assessment was carried out for indicator fish species in several steps:

- 1) Screening-level assessment, based on two different statistics: (i) the maximum of the 24-hr average temperatures; and (ii) the maximum of the rolling weekly average temperatures (MWAT), between 19 June and 11 December, 2012. Risk was evaluated at the harbour location that had the maximum 24-hour average temperature (Station 2-IH, selected as a 'worst-case' location) and also at the lake background locations for the surface and mid-depth during 19 June to 11 December, 2012. Each of the fish species was assessed over all relevant life stages (spawning, egg/incubation, larvae, growth/juvenile/young-of-year and adult) using thermal benchmarks at this location. Hazard quotients (HQs) were calculated to identify the fish that showed exceedance in the harbour and in the lake background locations during the period 19 June to 11 December, 2012.

- 2) A time-dependency assessment, based on the 24-hr average temperatures, to delineate the specific days when there are exceedances only at the selected harbour location (at the surface and mid-depth) and not at the lake background locations. This assessment was carried out for all the fish whose short term maximum ( $ST_{max}$ ) thermal benchmarks were exceeded by the maximum 24-hour average temperature at the harbour location (and not at the lake background locations).
- 3) A time-dependency assessment, based on a modelled harbour reference location representing location 2-IH with zero thermal discharge. As above, this assessment was carried out for all the fish whose short term maximum ( $ST_{max}$ ) thermal benchmarks were exceeded by the maximum 24-hour average temperature at the harbour location (and not at the harbour reference location).

An assessment of hypothetical operating conditions was also carried out using the modelled temperatures, to investigate the potential impacts on fish from  $\Delta T$  and  $T_{max}$  temperatures of 12°C and 34-35°C respectively.

For the fish community assessment, gillnetting was carried out in June and October 2012 to gather information on the fish species present in the harbour. The information from the community assessment was used to support the list of fish indicator species selected for the risk assessment. The fish residency study was carried out by radio-tagging individuals to determine whether the target fish were utilizing the harbour and specifically the areas around the PHCF discharges.

The egg incubation trials were conducted between October and December in a laboratory/field setting at the Wesleyville Hatchery and Aquatic Research Facility (WHARF) with water originating from Lake Ontario. Chinook salmon eggs were collected from fish caught with dipnets downstream of the fish ladder on the Ganaraska River in Port Hope. Thermal effects benchmarks were derived based on observations of mortality, hatching timing and deformities from several experimental treatments. Study details are provided in Section 6 of SENES (2013c).

#### 7.2.3.2 Results

Temperature measurements from the turning basin, approach channel and lake background locations showed that, in general, the harbour temperatures are higher than the lake temperatures; this is expected, as the harbour is a sheltered environment.

The gillnetting in June identified 12 different species in the harbour, with the dominant species being yellow perch, alewife and emerald shiner. Other than rainbow trout and alewives, the majority or all individuals were adults. In the October netting, five different species were identified. All were adults.

Overall, tagged fish use of the turning basin was limited with only three fish spending more than 1 hour there. The approach channel was frequented more than the turning basin, with seven fish spending between 7-23% of their time there. The residency study results confirmed that the salmonid species are not present in the harbour during the early life stages.

Thermal effects benchmarks were derived based on observations of mortality, hatching timing and deformities during the egg incubation trials. The main benchmark developed from the trials was a  $\Delta T$  of 3°C for the egg/incubation life stage. However, this benchmark could not be considered in the risk



assessment calculations since it was based on studies conducted in October and December, a time period for which sufficient temperature measurements with and without discharge were not available.

The screening-level risk assessment identified exceedances at the harbour location (location 2-IH) for most fish at mid-depth, and for two fish (Alewife and Rainbow Trout) at the surface. However, whenever the temperatures at 2-IH resulted in an exceedance, there was a corresponding exceedance at the lake background locations (10-CW & 11-CE) at the surface and mid-depth, indicating no undue risk. This result occurred with both types of temperature statistic (i.e., maximum 24-hour average and MWAT). It was found though that during times of high temperature (i.e., just below maximum temperature values), there were exceedances at harbour locations without corresponding exceedances at lake background locations, as shown using two time-dependency assessments. The first assessment used Lake Ontario locations as a reference point; however, it was determined that naturally-occurring upwelling in the lake confounded the results and it was recommended that these events not be included in the list of relevant exceedances. The second time-dependency assessment used modelled temperatures at harbour reference location, i.e., under conditions of zero thermal discharge. This showed that nearly every time there were exceedances at the selected harbour location (2-IH), there were also exceedances at the modelled harbour reference location (representing the same location 2-IH in the harbour, but with zero thermal discharge). There were a small number of occasions where measured harbour temperatures resulted in an exceedance but modelled harbour reference temperatures did not. These were brief and infrequent (2 based on ST max and 2 based on MWAT).

Overall, the risk assessment did not identify exceedances that were exclusive to the harbour. This applies to both MWAT and short-term (maximum 24-hr average) temperatures. However, during the summer months, there were some occurrences of high temperatures (i.e., exceeding but not the worst-case maximum values) at harbour locations that did not have a corresponding exceedance at background locations. This occurred for both MWATs and maximum 24-hour average temperatures, and at both lake and harbour reference locations. In many of these instances, the background locations were cooler likely due to upwelling events in the lake, or because the harbour is protected, geometrically, and therefore warmer than the lake.

An assessment of hypothetical operating conditions was also carried out, to investigate the potential impacts on fish from  $\Delta T$  and  $T_{max}$  temperatures of 12°C and 34-35°C respectively. As expected, potential HQ exceedances were identified for the same fish as identified for current operating conditions as well as several additional fish species.

## 7.2.4 Thermal Risk Assessment Follow Up (SENES 2014b)

### 7.2.4.1 Objectives

The *Port Hope Conversion Facility Thermal Risk Assessment Follow Up* (SENES 2014b) was carried out to study the impact of PHCF thermal discharges on fish species found in the harbour. Specifically, this involved a spring/summer 2014 fish tagging program in the Port Hope harbour, and thermal plume modelling combined with a  $\Delta T$  risk assessment for the September to December period for 2011, 2012 and 2013. The assessment was conducted in part to determine whether an effluent temperature amendment

to the current PHCF Environmental Compliance Approval (ECA) 4998-9CKL7F effluent temperature limits could be justified.

#### 7.2.4.2 Methodology

Thermal plume modelling for the period of 1 September to 30 December for 2011, 2012 and 2013 was carried out to estimate the  $\Delta T$  values (discharge minus no discharge) in the harbour. Modelling was carried out at different stations within the turning basin, the approach channel and one in the Ganaraska River, which is representative of background conditions, based on measured flow and temperature data with and without discharges. The modelled  $\Delta T$  was compared to the  $\Delta T$  benchmark that was derived as part of the 2013 risk assessment (SENES 2013c).

This risk assessment followed the thermal effects risk assessment methodology provided in CSA Standard N288.6 (CSA 2012), wherever possible. For example fish indicator species were selected based on knowledge of the site and field observations of species and habitats present. Stakeholder input was also incorporated into the selection of indicator species. Temperatures were modelled at 10 stations in the harbour, the approach channel and the Ganaraska River from 1 September to 30 December for 2011, 2012 and 2013 based on measured discharge temperatures for those time periods. The time period was recommended in the previous thermal study (SENES 2013c) in which  $\Delta T$ s ( $\Delta$  between discharge and no discharge scenarios) were not available. This period covers the incubation time for Chinook Salmon such that the benchmark derived in the previous study could be applied. Modelled temperatures during discharge and no discharge conditions at each station were summarized into rolling weekly average temperatures (WATs) for three depth scenarios: surface, mid-depth and bottom.

For each of the stations, the temperature difference between the modelled discharge and no discharge scenarios at the surface, mid-depth and bottom were compared to benchmark values of 3°C derived for Chinook salmon by WHARF (SENES 2013c) and 4°C for walleye from Loomis (2013).

To assess whether the maximum effluent temperature limit could be increased, a short-term dynamic risk assessment was completed looking at the impact on fish in the turning basin based on current discharge temperatures. The short-term dynamic risk assessment looked at the 24-hour average temperatures for fish (and corresponding life stages) that would be present in the turning basin during the time period of the assessment (13 August to 30 December for 2011, 2012 and 2013) and compared the highest hourly average from each 24-hour period to available short-term benchmark values. For each day that a BV was shown to exceed, the temperature at the reference location and the temperature at the same station in the no discharge scenario were assessed. If the temperature in either of these cases exceeded the BV, the exceedance was not considered to be associated with PHCF operations.

Fish tagging was conducted from May 13 to September 15, 2014, the results of which were used to verify the results of the risk assessment.

### 7.2.4.3 Results

The  $\Delta T$  risk assessment (discharge vs no discharge scenarios) showed that:

- In 2011 one or more of the benchmarks were exceeded at least once at every station in the turning basin during the time period (13 August to 30 December). At most stations and most depths, the benchmarks were only exceeded during the month of December, when the disparity between the discharge and no discharge scenarios is greatest. At mid depth at Station 8, in direct proximity to the  $UO_2N$  discharge, one or more of the benchmarks were exceeded at least once in every month of the time period.
- In 2012, the benchmarks were not exceeded at any stations in the turning basin at surface or bottom depth. At mid depth at Station 8, one or more of the benchmarks were exceeded at least once in September, October and November. While there were exceedances over 4 months, they were in a localized area at the mouth of the discharge.
- In 2013, the benchmarks were not exceeded at any station in the turning basin at surface or bottom depth. At mid depth at Station 8, one or more of the benchmarks were exceeded at least once in September. While there were exceedances over 2 months, they were in a localized area at the mouth of the discharge.

The short-term risk assessment showed that at current discharge temperatures, the benchmark values were exceeded at more than one station in more than one month over the time period, even after screening out days that also exceeded at that reference location and in the no discharge scenario in 2011 and 2012. In 2013, no exceedances existed after screened for reference location and no discharge scenario. Although it was concluded that the discharges would be unlikely to produce population level effects, there was a lack of justification for an increase in the current ECA maximum effluent temperature limit of 30°C.

There have been no exceedances of the ECA maximum  $\Delta T$  discharge limit of 10°C since it came into effect on March 31, 2011. It was concluded that an ECA amendment request to increase the limit to 11°C would be supported by:

1. The conclusions of the current  $\Delta T$  assessment showing no undue population level effects to fish;
2. Supporting evidence from field observations (tagging) showing that only a small number of fish enter the harbour; and
3. The short-term  $\Delta T$  risk assessment compared to the current discharge risk assessment, showing negligible increase in the risk to fish from a 2°C increase in effluent discharge temperature.

In comparing the risk assessment results to fish tagging results, it was concluded that fish in the area do not spend a significant amount of time in the turning basin during the October/November period; however, the majority of the  $\Delta T$  exceedances in the turning basin occurring in December.

### 7.2.5 Conclusions

The SENES (2012a) risk assessment calculations identified potential risk to some fish species; however, this was based on the assumption that fish would reside in the harbor for the entire duration of the study when, in reality, the residence time is unknown and this is likely a conservative assumption given the known

biology and behavior of fish in Lake Ontario (Scott and Crossman 1998). It was recommended that the residency time of key indicator species be verified in future studies, and that *in situ* egg incubation trials be conducted in order to obtain field-based benchmarks should the fish residency study show that fish are spawning in the harbour. Additional benthic invertebrate sampling was recommended to confirm the results of the field study. To address temperature-related data gaps, continuous monitoring of temperature within the harbor was recommended, coinciding with fish residency data obtained through acoustic tagging.

The 2013 thermal effects risk assessment study (SENES 2013c) conducted a residency study in response to the 2012 study (SENES 2012a) and found that, overall, tagged fish use of the turning basin was limited and the approach channel was slightly more frequented. Salmonid species were not present in the harbor during early life stages. A thermal benchmark was also derived from *in situ* egg incubation studies; however, it was not used in the risk assessment since it was calculated based on data for a different time period than that used in this risk assessment. Overall, the risk assessment did not identify exceedances that were exclusive to the harbour. Some exceedances were noted in the summer months, but these were likely due to upwelling events in the lake and geometry of the harbour. The following recommendations for improvement of the study were made:

- Thermal plume modelling for October to December, to estimate the  $\Delta T$  values in the harbour (i.e., with and without discharge). The estimated harbour  $\Delta T$  values would be compared to the  $\Delta T$  benchmark derived in this study; and
- Spring/summer fish tagging, to improve understanding of fish species that spawn in the spring and summer. The following representative species were suggested for tagging: white sucker or brown bullhead (to represent bottom-feeding fish) and Northern pike or perch (to represent predatory fish).

In response to these recommendations, SENES (2014b) completed a thermal risk assessment follow up. The risk assessment for October to December for 2011, 2012 and 2013 concluded that:

- 2011: There are exceedances of one or more benchmarks in all months and at all stations assessed (excluding the reference station). There is a potential for impact in the turning basin indicated based on 2011  $\Delta T$ s.
- 2012: There are exceedances of 2 benchmarks at Station 8, mid-depth (near the discharge) in September, October and November. There is potential for impact indicated in a small localized area near the discharge at mid-depth based on 2012  $\Delta T$ s.
- 2013: There is an exceedance of 1 benchmark at Station 8, mid-depth (near the discharge) in September. No undue impact on fish is expected based on 2013  $\Delta T$ s.

It was concluded from the tagging study that fish in the area do not spend a significant amount of time in the turning basin during the October/November period; however, many of the 2011  $\Delta T$  exceedances in the turning basin occur in December. Thus, the data are not exactly correlated with respect to month and it was suggested that it could be useful to conduct a tagging study in December.

## 7.3 Acoustic Assessment

### 7.3.1 Introduction & Overview

The Cameco PHCF (the Facility) currently operates under Certificate of Approval (Air) number 1036-6UGKQ7, which was issued by the Ministry of the Environment (MOE) on October 24, 2006. An Acoustic Assessment Report (AAR) (SENES 2012b) and Noise Abatement Action Plan (NAAP) (SENES and Seward 2012) were submitted to the MOE in December 2012 in support of an Environmental Compliance Approval (ECA) application to extend limited operational flexibility. The NAAP has since been implemented, and an Acoustic Audit was conducted by Golder Associates Ltd. (Golder 2013b) which confirmed that the Facility is operating in compliance with the appropriate sound level limits.

SENES recently updated the AAR to account for new sources at the Facility and update the sound level data for the sources that were mitigated as part of the NAAP (SENES 2014c).

### 7.3.2 Objectives

The purpose of the updated AAR (SENES 2014c) was to update the predictions of the overall noise emissions of the Facility from new sources at the Facility, extending the operations of the Grit Blaster to include night-time operations, extending the operation of the Taylor forklifts and tanker trucks to include evening hours, and post-mitigation source measurement data to sources that were mitigated as part of the NAAP following submission of the AAR. The Facility is not a significant source of vibration, therefore there was no need for a vibration assessment.

### 7.3.3 Methodology

The updated AAR included the following changes:

- Updated source data for sources in the NAAP (from Golder measurement data);
- One (1) new HVAC unit on Building 2;
- One (1) new fan on Building 3;
- Two (2) new fans on Building 20;
- Two (2) new fans on Building 50;
- Increased operating hours for the Grit Blaster Stack (Building 5B); and
- Extending Taylor forklift and tanker truck activities to evening hours.

All other source data was identical to the December 2012 AAR (SENES 2012b), and was not altered for the updated assessment. Predictions were provided for the same five (5) points of reception (PORs) as the December 2012 AAR (R1a to R5a). The receptor locations identified for the assessment were defined as Class 1 Urban, which is defined as *an area with an acoustical environment typical of a major population centre, where the background sound level is dominated by the activities of people, usually road traffic, often referred to as urban hum.*

The sound levels for the sources that were the subject of the update were based on manufacturer sound level data and on-site measurements conducted by Golder during the Acoustic Audit in 2013. The new sources and associated sound power levels were applied to the existing model of the PHCF that was submitted to the MOE with the December 2012 AAR. The calculations were performed using prediction software consistent with the ISO 9613-2 standard. No changes were made to the model configuration or to any of the existing sources in the model, other than those summarized above.

The updated sound level predictions at the PORs were compared to acoustic assessment criteria that were established in accordance with sound level limits defined in MOE publication NPC-205 in 2012, and updated in accordance with MOE publication NPC-300. Background sound levels in the vicinity of the Facility are primarily attributable to local road traffic, passenger and freight rail traffic along two adjacent rail lines and wave noise from Lake Ontario. Influences from nearby rail traffic were not included in the determination of background.

### **7.3.4 Results**

Detailed predicted sound levels at the identified PORs due to each noise source are summarized in the source document (Tables 4, 5 and 6 in SENES 2014c), as well as predicted sound level contours (Figures 8 and 9 in SENES 2014c). The cumulative noise impacts at the identified PORs are summarized below in Table 7.4.

Table 7.4 Acoustic Assessment Summary Table

Point of Reception ID	Point of Reception Description	Time of Day	Sound Level at Point of Reception (dBA) (Leq)	Verified by Acoustic Audit (Yes/No)	Performance Limit (dBA) (Leq)	Compliance with Performance Limit (Yes/No)
<b>Outdoor Points of Reception</b>						
R1a	Residential (Yard)	Day	50	Yes	50	Yes
		Evening	50	Yes	50	Yes
R2a	Residential (Yard)	Day	47	Yes	50	Yes
		Evening	47	Yes	50	Yes
R3a	Residential (Yard)	Day	47	Yes	50	Yes
		Evening	47	Yes	50	Yes
R4a	Residential (Yard)	Day	50	Yes	50	Yes
		Evening	50	Yes	50	Yes
R5a	Residential (Yard)	Day	46	Yes	50	Yes
		Evening	46	Yes	50	Yes
<b>Plane of Window Points of Reception</b>						
R1b	Residential (Facade)	Day	49	Yes	50	Yes
		Evening	49	Yes	50	Yes
		Night	44	Yes	46	Yes
R2b	Residential (Facade)	Day	49	Yes	50	Yes
		Evening	49	Yes	50	Yes
		Night	45	Yes	45	Yes
R3b	Residential (Facade)	Day	47	Yes	50	Yes
		Evening	47	Yes	50	Yes
		Night	43	Yes	45	Yes
R4b	Residential (Facade)	Day	50	Yes	50	Yes
		Evening	50	Yes	50	Yes
		Night	46	Yes	46	Yes
R5b	Residential (Facade)	Day	47	Yes	50	Yes
		Evening	47	Yes	50	Yes
		Night	45	Yes	45	Yes

### **7.3.5 Conclusions**

The sound level measurements and analysis indicated that current sound emissions from the Facility comply with the applicable MOE sound level limits with no need for further abatement.

## **7.4 Assessment of Acute Effects from Stormwater Pulses**

As discussed in Section 3.2 and shown in the example figure below, the hydrodynamic modelling results demonstrate that contaminant concentration peaks can occur in the Harbour surface water following rain events.



Final – Environmental Risk Assessment for the Cameco Port Hope Conversion Facility

Figure 7.1. Modelled Incremental\* Concentration of Uranium in Surface Water, Scenario 2a – Dynamic, Stormwater Only

\* - Incremental: in this scenario, “Incremental” represents only the contribution of stormwater to Harbour concentrations.

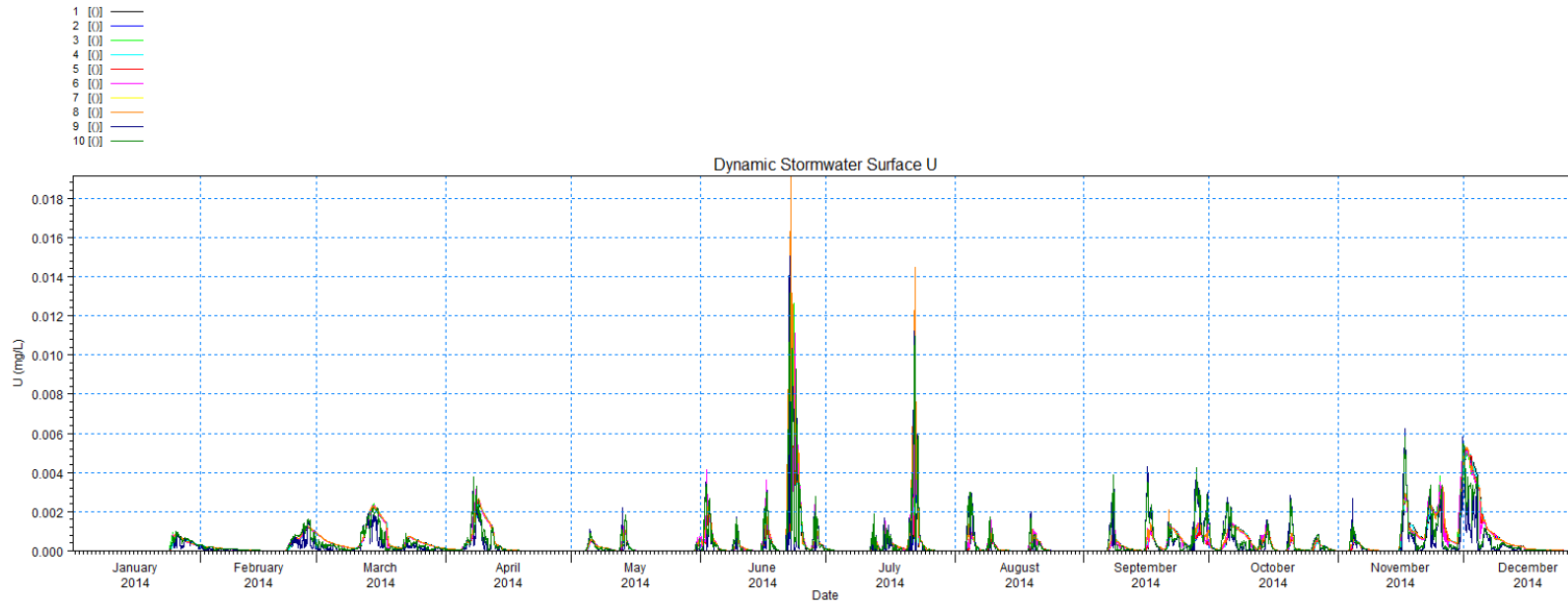

In order to assess the potential acute effects on aquatic biota in the Harbour from a rain event (i.e., effects from short-term exposure to the peak concentration), the maximum modelled (peak) concentration of each contaminant can be compared to acute toxicity benchmarks.

The TRVs selected for the acute assessment are presented in Table 7.5. All TRVs are obtained primarily from US EPA ECOTOX database, with the chosen source reference indicated. The following assumptions were made when selecting criteria:

- only acute studies (typically less than 72 hours of exposure) were considered;
- if multiple study results were available, the lowest criterion for each biota type was selected;
- only relevant species were considered; and
- if no acute benchmark was available, a value was estimated from a chronic benchmark.

Table 7.5 MNO: Acute TRVs for Aquatic Biota

COPC	Biota Type	Test type and duration	TRV (µg/L unless otherwise stated)	Ref	Max Modelled concentration in harbour <sup>4</sup> (µg/L unless otherwise stated)	Location and Date of Maximum	Exceedance?
Ammonia	Fish	Lowest 0.347d LC50 (MOR)	420	WPRB (1960)	49	Station 8, Surface, 22/06/2014 8:00:00 PM	No
Ammonia	Zooplankton	Lowest 1-2d LC50 (MOR)	1,500	Gyore & Olah (1980)	49	Station 8, Surface, 22/06/2014 8:00:00 PM	No
Arsenic	Fish	Lowest 1d LC50 (MOR)	71,000	Buhl & Hamilton (1990)	86	Station 3, Bottom, 22/06/2014 8:00:00 PM	No
Fluoride	Fish	1d LC50 (MOR)	560,000	Wallen <i>et al.</i> (1957)	88	Station 3, Bottom, 22/06/2014 8:00:00 PM	No
Fluoride	Zooplankton	Lowest 1d EC10 (MOR)	27,900	Hickey (1989)	88	Station 3, Bottom, 22/06/2014 8:00:00 PM	No
Uranium	Algae	72d LC50	200 (selected value for high hardness) <sup>1</sup>	VST (2004)	25	Station 3, Bottom, 22/06/2014 8:00:00 PM	No
Uranium	Fish	Lowest 96h LC50	1,800 (selected value for high hardness) <sup>1</sup>	VST (2004)	25	Station 3, Bottom, 22/06/2014 8:00:00 PM	No

COPC	Biota Type	Test type and duration	TRV (µg/L unless otherwise stated)	Ref	Max Modelled concentration in harbour <sup>4</sup> (µg/L unless otherwise stated)	Location and Date of Maximum	Exceedance?
Zinc <sup>2</sup>	N/A	N/A	189	<sup>2</sup>	31	Station 3, Bottom, 22/06/2014 8:00:00 PM	No
Radium-226 <sup>3</sup>	N/A	N/A	1.1 Bq/L	<sup>3</sup>	0.012 Bq/L	Station 3, Bottom, 22/06/2014 8:00:00 PM	No

Notes:

N/A – Not applicable.

MOR – Mortality.

TRV - toxicity reference value (effects benchmark).

<sup>1</sup> Study results provided for various water hardness levels; for this study, the results for the highest hardness (240 mg/L CaCO<sub>3</sub>) were selected, since Port Hope harbour average hardness is 176 mg/L CaCO<sub>3</sub> and stormwater average hardness is 298 mg/L CaCO<sub>3</sub>.

<sup>2</sup> Acute values for zinc not available; therefore, Criterion Maximum Concentration (CMC) value estimated using the approach from U.S. EPA National Recommended Water Quality Criteria (U.S. EPA 2009), based on harbour average hardness of 176 mg/L.

<sup>3</sup> Saskatchewan Surface Water Quality Objective is 0.11 Bq/L. Converted to acute benchmark using multiplier of 10 (assumption made for estimation purposes). Note that this value was used in previous versions of the Saskatchewan Surface Water Quality Objectives but not in the most recent version. Communication from Saskatchewan Environment has indicated that they expect this value to still be considered.

<sup>4</sup> Model Scenario 2a – Dynamic Stormwater Discharge; max of locations 1-10; max of surface, middle and bottom depths.

As seen in Table 7.5, the incremental concentrations of all contaminants were below the benchmark values, indicating that the contribution from storm events is not expected to cause undue acute effects in aquatic biota in the harbour.

The maximum (peak) concentration of all of the contaminants modelled occurred on the same date (June 22) at the same time (8:00 PM). This corresponds to the date of the largest precipitation event of the year (42 mm, as per Environment Canada Historical Climate Data, EC 2010). This is also demonstrated in Figure 7.2 below.

Figure 7.2. Precipitation Statistics and Modelled Incremental\* Harbour Concentrations, Ra-226, Scenario 2a, Station 3

\* - Incremental: in this scenario, "Incremental" represents only the contribution of stormwater to Harbour concentrations.

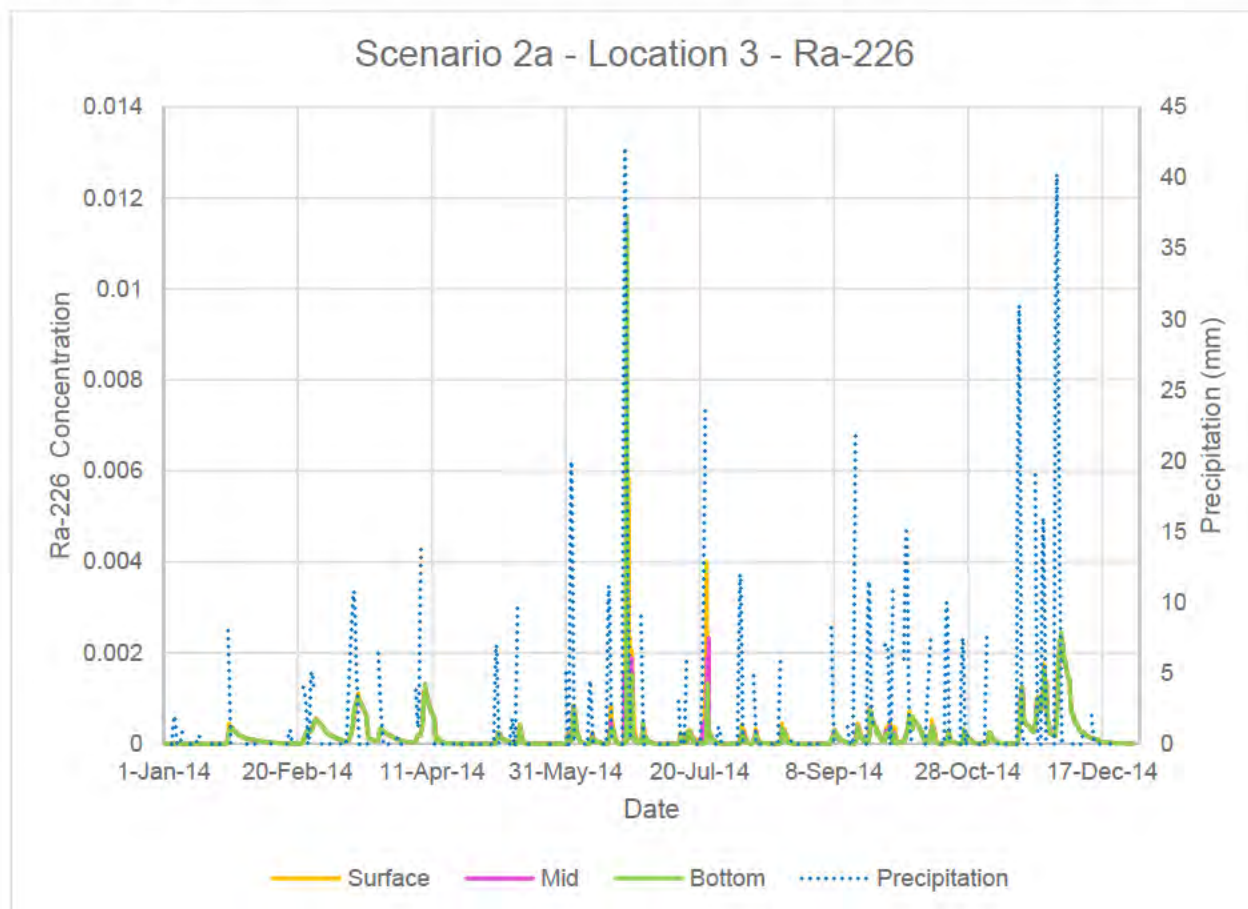

## 7.5 Uncertainties in the Assessment of Physical Stressors

- **Thermal Effects Receptors and Residency:** There is uncertainty associated with the presence of fish in the Harbour and surrounding areas, with respect to both species and timing. Some of the uncertainty has been addressed by conducting residency/tagging studies, as discussed above. In addition, the risk calculations assumed that the assessed fish spend all of their time (i.e., in the period being studied) in the Port Hope Harbour, which is a conservative assumption given the known biology and behaviour in Lake Ontario. *Degree of uncertainty: Low*
- **Thermal Effects Benchmarks:** There are data gaps in the thermal benchmarks for both fish and benthic invertebrates. For benthic invertebrates, there is a very low availability of benthos thermal benchmarks values in literature, a large number of calculations could not be completed; however, based on the available data, no potential risk to benthic invertebrates was identified from exposure

to the thermal plume. For fish, while more literature and experimental values were available, there were not sufficient benchmarks to cover each species and life stage. *Degree of uncertainty: Medium.*

- **Timing of Thermal Data:** There is also uncertainty associated with the seasonality of the benchmarks, relative to the timing of available data. For example, in the earlier thermal effects studies, benchmarks were derived for a time period over which temperature data were not available. However, it is noted that in later studies, Cameco was able to address this using modelling, as well as by timing the field studies to correspond to the available benchmarks. *Degree of uncertainty: Low.*
- **Acoustic Effects Data and Modelling:** Due to the dynamic nature of activities at the PHCF, there is uncertainty in the sources and therefore in the sound levels for the assessment. This was addressed by ensuring that the most recent equipment, measurements and operating hours were reflected. The updated sources and associated sound power levels were applied to the existing model of the PHCF that was submitted to the MOE in 2012. The calculations were performed using prediction software consistent with the ISO 9613-2 standard. No changes were made to the model configuration or to any of the existing sources in the model, other than those summarized above. *Degree of uncertainty: Low.*
- This ERA did not include an assessment of multi-stressor effects, including interactions between multiple physical stressors, or the combination of chemical, radiological and physical stressors. A detailed quantitative assessment of these interactions is beyond the scope of the present study, and, there is not readily-available information with which to investigate these interactions. This may result in an underestimate of the risk for some receptors. *Degree of uncertainty: Medium.*

Table 7.6 outlines some of the uncertainties identified in the assessment of physical stressors and how in general, they have been overcome by using conservative assumptions that are likely to lead to an overestimate of exposures (and therefore no change in the conclusions).

**Table 7.6 Physical Stressors – Summary of Uncertainties**

Uncertainty	Likely Leads to Overestimate	Possibly Leads to Underestimate	Neither Overestimate or Underestimate
Presence of fish in the Harbour and surrounding areas, with respect to both species and timing (for thermal effects study).	X		
Data gaps in thermal effects benchmarks (fish and benthos)			X
Inputs into acoustic assessment			X
Synergism, potentiation, antagonism, additivity of toxic effects		X	

## 8 CONCLUSIONS AND RECOMMENDATIONS

This section presents the conclusions and recommendations of the present ERA.

### 8.1 Summary of ERA Results

The question originally posed in Section 1.1 is:

*Is there potential for significant environmental (i.e. ecological and human health) effects from current emissions associated with Cameco’s Port Hope facility operations?*

This has been addressed by conducting a multi-tier human health and ecological risk assessment for radiological and non-radiological (i.e., chemical) COPCs as well as physical stressors such as temperature and noise.

Table 8.1 provides a simplified representation of the results of the present ERA.

Table 8.1 Summary of ERA Results

Stressor Type	Members of the Public	Aquatic Biota	Terrestrial Biota
<b>Radiological</b> (see list of radionuclides in Table 2.1)	No adverse effect expected from COPCs associated with PHCF operations.	No adverse effect expected from COPCs associated with PHCF operations.	No adverse effect expected from COPCs associated with PHCF operations.
<b>Non-Radiological</b>	No adverse effect expected from COPCs associated with PHCF operations. Arsenic exposure is below background, but it is recommended to minimize arsenic risk to the extent that it is practical. The facility has restricted the arsenic levels in chemicals it is using (as of 1989); see discussion in Section 2.3.5.	No adverse effect expected from COPCs associated with PHCF operations.	Potential for adverse effects from F, PHCs in limited area that is not suitable habitat (i.e., the grass patch along Harbour wall, as illustrated in Figure 8.1)
<b>Physical*</b>	N/A	No I&E issues identified. Thermal exceedances tend to be limited spatially (i.e., localized near the discharge)	No adverse effect expected from stressors associated with PHCF operations.(i.e., noise)

**Notes:**

N/A – Not applicable or not assessed.

\* - Physical stressors include fish entrainment, fish thermal effects, fish acute stormwater effects and acoustic assessment. For terrestrial receptors, only acoustic assessment is applicable.

The results shown in Table 8.1 are supported by extensive site characterization data, and a multi-source, multi-pathway risk assessment.

The summary in Table 8.1 is a very simplified representation of the ERA results. It does not list specific assumptions made in Tier 2 (e.g., that Al, B, Ba, Cd, Cl, Cr, Cu, Fe, K, Mn, Na, Ni, Pb, Sb, Se and Sr, V and Zn (off-site zinc only) are not associated with current PHCF operations); these details can be found in Sections 5 and 6 above.

## 8.2 Recommendations

Based on the results of the ERA, the following recommendations have been developed:

- i) Contamination in the grass patch along the Harbour walls needs to be addressed, in coordination with VIM and PHAI.
- ii) Cameco should ensure that decision-making during VIM is risk-informed where appropriate.
- iii) Once remediation activities (i.e., under VIM) are complete, Cameco should review its soil monitoring program to ensure that it is adequate for the new conditions.



Figure 8.1. Off-Site Grass Strip Exceedances

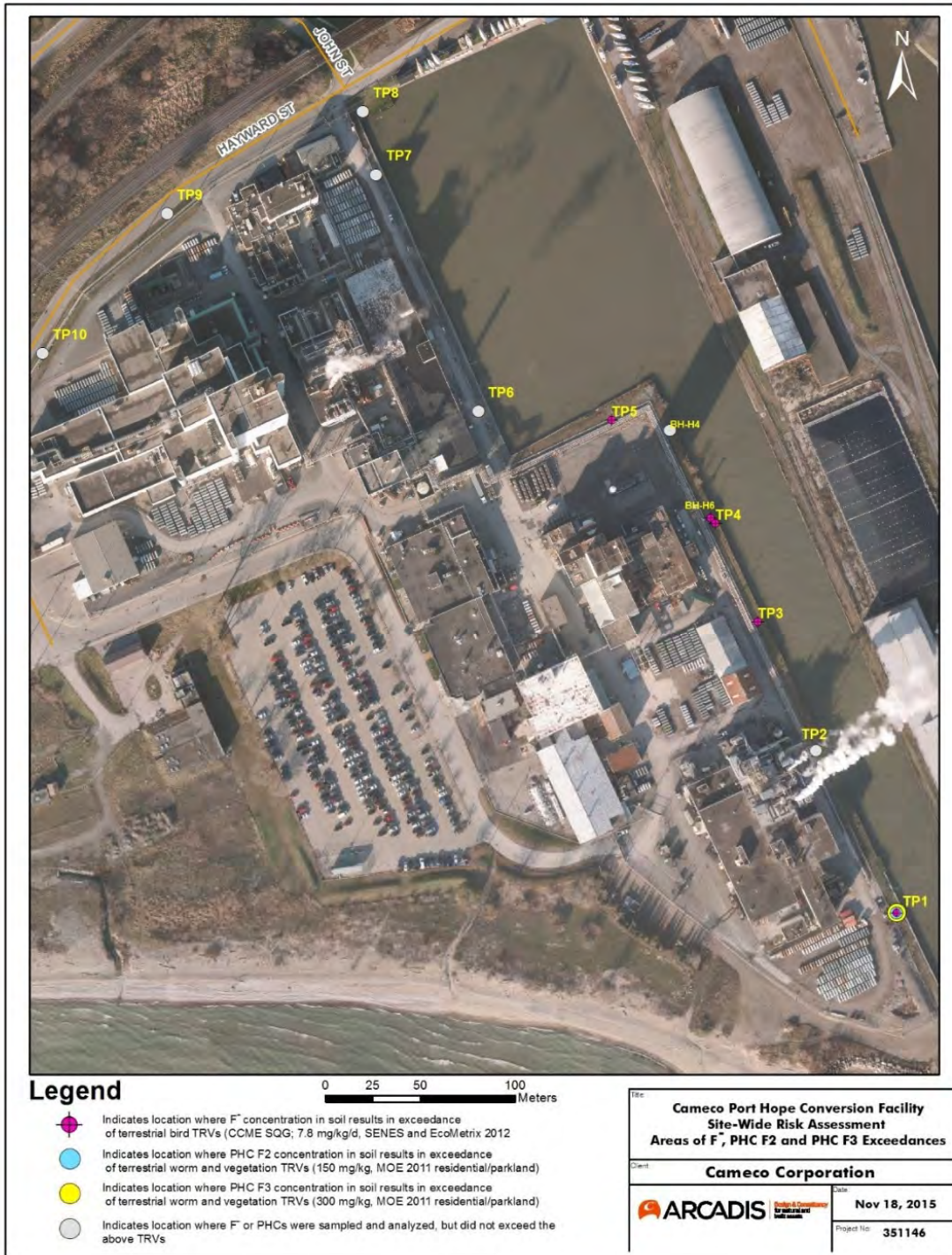

## 9 QUALITY ASSURANCE AND QUALITY CONTROL

Arcadis has an internal Quality Management System that has been certified to ISO 9001:2008. The Arcadis QMS was applied to the ERA process. It includes (but is not limited) the following elements that are required under CSA N288.6 (Section 10.2):

- i. Data gathering: Sources (either Cameco internal monitoring data, or external references) documented. Where possible, obtained data in Excel to minimize copy errors.
- ii. Data management: Shared data folder to ensure all team members have access to the most up-to-date information. Summary of data and sources in report. Document and e-mail naming convention to optimize version tracking.
- iii. Data analysis: Use of QA'ed calculation models for HH Rad, Eco Rad, Eco NonRad. Use of QA'ed spreadsheet models for HH Rad. Screening was QA'ed.
- iv. Report preparation: Tracked changes, OneDrive, etc. to manage multiple inputs.
- v. Record keeping: Bi-weekly tracking (at a minimum) to ensure project progress. Management of team resources to ensure staff are available when required, e.g., for QA or modelling.

Much of the data used in this assessment comes from previous Arcadis (formerly SENES) studies that were already reviewed and accepted by CNSC. Internal peer review is performed for all major aspects of the risk assessment, as seen in Table 9.1 below:

Table 9.1 Internal Peer Review of ERA

Section	Prepared By	Reviewed By	Example Findings
Screening	[REDACTED]	[REDACTED]	
Human Rad	[REDACTED]	[REDACTED]	Improvements made on receptor characteristics Small correction made to specific activity calculation
Human NonRad	[REDACTED]	[REDACTED]	Updated PHC TRVs to include fractions
Eco Rad	[REDACTED]	[REDACTED]	Small typo corrected in rad concentration
Eco NonRad	[REDACTED]	[REDACTED]	
Thermal	[REDACTED]		
Impingement and Entrainment	[REDACTED]		

## 9.1 Monitoring Program

As discussed in the 2014 Annual Groundwater and Surface Water Review Report (Golder, 2015), within the monitoring program, blind duplicate groundwater samples were collected and submitted to the Cameco laboratory for analysis as part of the quarterly sampling. The duplicate samples were given sample identifiers that were recorded at the time of sample collection for correlation with the original sample.

In accordance with the monitoring program, samples collected from Q2 2014 were submitted to the SGS laboratory for comparison to Cameco laboratory data. SGS analyzed the samples for an expanded suite of metals and general chemistry parameters relative to the Cameco laboratory, with exception to radium-226. Duplicate samples of VOCs were also submitted to SGS for analysis on a quarterly basis.

A relative percent difference (RPD) calculation was conducted on the results for each original and duplicate sample. The calculations were completed using the following formula:

$$\text{Relative Percent Difference} = \frac{(\text{Original sample Result} - \text{Duplicate Sample Result})}{(\text{Original sample Result} + \text{Duplicate Sample Result})/2} \times 100\%$$

The RPD calculations were applied to a total of 157 sample results for which the above formula is applicable (i.e., where the average of the two reported concentrations were approximately five times higher than the RDL for both the Cameco and SGS laboratories). Golder (2015) presents a detailed discussion of the calculated RPD values, and compares them to the acceptable levels, which are 20% for metals and inorganics in groundwater and 30% for VOCs.

## 10 REFERENCES

- Adams, A.W., Cunningham, F.E., and Munger, L.L. 1975. *Some Effects of Layers of Sodium Sulfate and Magnesium Sulfate in their Drinking Water*. *Poult. Sci.* 54:707.
- Agency for Toxic Substances and Disease Registry (ATSDR). 2004a. *Toxicological Profile for Cobalt*. April.
- Agency for Toxic Substances and Disease Registry (ATSDR). 2004b. *Toxicological Profile for Ammonia*. September.
- Agency for Toxic Substances and Disease Registry (ATSDR). 2013. *Toxicological Profile for Uranium*. September.
- Agency for Toxic Substances and Disease Registry (ATSDR). 1999. *Toxicological Profile for Total Petroleum Hydrocarbons (TPH)*. September.
- Agency for Toxic Substances and Disease Registry (ATSDR). 1997. *Toxicological Profile for Chloroform*. September.
- AMEC Earth & Environmental (AMEC). 2005. *Terrestrial Environment Environmental Effects Assessment Report for the Port Hope Project*. LLRWMO-03780-ENA-12002. Report to the LLRWMO.
- Amiro, B.D. 1997. *Radiological Dose Conversion Factors for Generic Non-Human Biota Used for Screening Potential Ecological Impacts*. In *J. Environ. Radioactivity*. 35(1):37-51.
- Anderson, R.L., C.T. Walbridge, and J.T. Fiandt. 1980. *Survival and Growth of Tanytarsus dissimilis (Chironomidae) Exposed to Copper, Cadmium, Zinc, and Lead*. *Arch. Environ. Contam. Toxicol.* 9(3):329-335 (Author Communication Used).
- Bechtel Jacobs Company LLC. 1998. *Empirical Models for the Uptake of Inorganic Chemicals from Soil by Plants*. Bechtel Jacobs Company LLC, Oak Ridge, TN.
- Beyer, W.N., E. Conner and S. Gerould. 1994. *Estimates of Soil Ingestion by Wildlife*. *Journal of Wildlife Management*. Vol. 58. Issue 2.
- Bringmann, G. and R. Kuhn. 1959a. *Comparative Water-toxicological Investigations on Bacteria, Algae, and Daphnia*. *Gesundheitsingenieur* 80(4):115-120.

- Bringmann, G., and R. Kuhn. 1959b. *The Toxic Effects of Waste Water on Aquatic Bacteria, Algae, and Small Crustaceans*. Tr-Ts-0002 53:17390G / Gesund.Ing. 80:115-120 (GER) (ENGTRANSL)
- Birge, W.J., J.E. Hudson, J.A. Black, and A.G. Wasterman 1979a. *Embryo-larval Bioassays on Inorganic Coal Elements and In Situ Biomonitoring of Coal-waste Effluents*. In: D.E. Samuel, J.R. Stauffer, C.H. Hocutt, and W.T. Mason Jr. (eds.), *Surface Mining and Fish/wildlife Needs in the Eastern United States*. Fish and Wildlife Service, Office of Biological Services. FWS/OBS-78/81. U.S. Government Printing Office, Washington, D.C. pp. 97-104. {Cited in CCME 1999}.
- Birge, W.J. 1978. *Aquatic Toxicology of Trace Elements of Coal and Fly Ash*. In: J.H.Thorp and J.W.Gibbons (Eds.), *Dep.Energy Symp.Ser., Energy and Environmental Stress in Aquatic Systems*, Augusta, GA 48:219-240.
- Borgmann, U., Y. Couillard, P. Doyle and D.G. Dixon. 2005. *Toxicity of Sixty-three Metals and Metalloids to Hyalella azteca at Two Levels of Water Hardness*. *Environ.Toxicol.Chem.* 24(3):641-652.
- British Columbia Ministry of Environment (B.C. MOE). 2014. *Ambient Water Quality Guidelines*.
- Buhl, K.J., and S.J. Hamilton. 1990. *Comparative Toxicity of Inorganic Contaminants Released by Placer Mining to Early Life Stages of Salmonids*. *Ecotoxicol.Environ.Saf.* 20(3):325-342
- CalEPA (California Environmental Protection Agency). 2008. *Inorganic Arsenic Reference Exposure Levels*. Appendix D1. Office of Environmental Health Hazard Assessment. Available: [http://oehha.ca.gov/air/toxic\\_contaminants/pdf\\_zip/arsenic\\_112508.pdf](http://oehha.ca.gov/air/toxic_contaminants/pdf_zip/arsenic_112508.pdf)
- California Environmental Protection Agency (CalEPA). 2000. *Determination of Noncancer Chronic Reference Exposure Levels*. Available at: <http://www.oehha.ca.gov/air/allrels.html>. Last accessed March 2010.
- Camargo, J.A., and J.V. Tarazona. 1991. *Short-term Toxicity of Fluoride ion (F-) in Soft Water to Rainbow Trout (Salmo gairdneri) and Brown Trout (Salmo trutta fario)*. *Fluoride* 24(2):76-83.
- Cameco Corporation (Cameco). 2015a. E-mail from R. Peters to N.C.Garisto. *RE: PHCF Question*. 24 September.
- Cameco Corporation (Cameco). 2015b. E-mail from R. Peters to N.C.Garisto. *Arsenic in HF*. 3 December.

Cameco Corporation (Cameco). 2014a. *Port Hope Conversion Facility (PHCF) 2014 Environmental Monitoring Program (EMP)*.

Cameco Corporation (Cameco). 2014b. Written Summary for Reporting Year 2013 - Basic Comprehensive Certificate of Approval (Air & Noise) 1036-6UGKQ7. May.

Cameco Corporation (Cameco). 2013. *Port Hope Conversion Facility (PHCF) 2013 Environmental Monitoring Program (EMP)*.

Cameco Corporation (Cameco). 2010. *Port Hope Conversion Facility (PHCF) Environmental Impacts and Test Plan*.

Cameco Corporation (Cameco). 2008. *Update on UO<sub>2</sub> Main Sump*. 23 October. Provided to SENES in electronic format.

Cameco Corporation (Cameco). 2007. *Updated EMP for Process Liquid Leakage from Building 50 (Port Hope Conversion Facility)*. December.

Canadian Council of Ministers of the Environment (CCME). 2014. *Canadian Environmental Quality Guidelines (CEQGs) and Supporting Documents (various years)*. Canadian Council of Ministers of the Environment (CCME). 2013. *Source to Tap. Infosheet for Phosphorus*. Available at: <http://www.ccme.ca/sourcetotap/phosphorus.html>

Canadian Council of Ministers of the Environment (CCME). 2011. *Canadian Water Quality Guidelines for the Protection of Aquatic Life, Factsheet: Chloride*.

Canadian Council of Ministers of the Environment (CCME). 2010. *Canadian Water Quality Guidelines for the Protection of Aquatic Life, Factsheet: Ammonia*.

Canadian Council of Ministers of the Environment (CCME). 2008. *Canada Wide Standards for Petroleum Hydrocarbons in Soil. Scientific Rationale. Supporting Technical Document*. December.

Canadian Council of Ministers of the Environment (CCME). 2002. *Canadian Water Quality Guidelines for the Protection of Aquatic Life, Factsheet: Inorganic Fluoride*.

Canadian Council of Ministers of the Environment (CCME). 2000. *Canada-Wide Standards for Petroleum Hydrocarbons (PHCs) in Soil: Scientific Rationale, Supporting Technical Document*, December.

Canadian Council of Ministers of the Environment (CCME). 1996. *A Protocol for the Derivation of Environmental and Human Health Soil Quality Guidelines*. National Contaminated Sites Remediation Program. March.

Canadian Nuclear Safety Commission (CNSC). 2000. *Radiation Protection Regulations SOR/2000-203 under the Nuclear Safety and Control Act*. 31 May.

Canadian Standards Association (CSA). 2012. *Environmental Risk Assessments at Class I Nuclear Facilities and Uranium Mines and Mills*. N288.6-12. June.

Canadian Standards Association (CSA). 2014. *Guidelines for Calculating Derived Release Limits for Radioactive Material in Airborne and Liquid Effluents for Normal Operation of Nuclear Facilities*. N288.1-14. September.

Canadian Wildlife Services (CWS). *Hinterland Who's Who*.

Cornell Laboratory of Ornithology. *Bird Guide*. Accessed at: <https://www.allaboutbirds.org/guide>.

Corporation of the Town of Port Hope (PH). 1994. *Town of Port Hope Sewer Use By-Law (30/94)*.

Department of Fisheries and Oceans (DFO). 1995. *Freshwater Intake End-of-Pipe Fish Screen Guideline*. 27 pp. {cited in SENES 2014a}

Dietrich, D. 2013. *Bubo virginianus* (On-line), Animal Diversity Web. Accessed at [http://animaldiversity.org/accounts/Bubo\\_virginianus/](http://animaldiversity.org/accounts/Bubo_virginianus/)

Environment Canada (EC). 2014. *Federal Interim Groundwater Quality Guidelines for Protection of Aquatic Life*.

Environment Canada (EC). 2013. Database of Environmental Quality Guidelines.

Environment Canada (EC). 2012. *Federal Contaminated Sites Action Plan (FCSAP) - Ecological Risk Assessment Guidance - Module C: Standardization of Wildlife Receptor Characteristics*. Environmental Stewardship Branch, Environment Canada. Ottawa, Canada.

Environment Canada (EC). 2010. *Environment Canada Historical Climate Data. 2010 Precipitation data from Cobourg STP (Climate Identifier 6151689)*. Retrieved from <http://climate.weather.gc.ca/climateData> in June 2015.

- Environment Canada/Health Canada (EC/HC PSL2). 2003. *Priority Substances List Assessment Report: Releases of Radionuclides from Nuclear Facilities (Impact on Non-Human Biota)*. Canadian Environmental Protection Act.
- Golder Associates Ltd. (Golder). 2015. *2014 Annual Groundwater and Stormwater Review Report, Cameco Corporation Port Hope Conversion Facility*. Prepared for Cameco Corporation. March.
- Golder Associates Ltd. (Golder). 2014. *2013 Annual Groundwater and Stormwater Review Report, Cameco Corporation Port Hope Conversion Facility*. Prepared for Cameco Corporation. March.
- Golder Associates Ltd. (Golder). 2013a. *2012 Annual Groundwater and Stormwater Review Report, Cameco Corporation Port Hope Conversion Facility*. Prepared for Cameco Corporation. March.
- Golder Associates Ltd. (Golder). 2013b. *Cameco Corporation Port Hope Conversion Facility Acoustic Audit*, Report Number 07-1112-0087, December. {cited in SENES 2014b}.
- Golder Associates Ltd. (Golder). 2011. *Stormwater Control Study, Cameco Corporation Port Hope Conversion Facility*. Prepared for Cameco Corporation. March.
- Golder Associates Ltd. (Golder). 2008. *Site-Wide Environmental Investigation Report, Cameco Corporation Port Hope Conversion Facility*. Report # 07-1112-0087. Prepared for Cameco Corporation. December.
- Gyore, K., and J. Olah. 1980. *Ammonia Tolerance of Moina rectirostris Leydig (Cladocera)*. Aquac.Hung.(Szarvas) 2:50-54
- Handford, B. 2001. *Podiceps auritus* (On-line), Animal Diversity Web. Accessed at [http://www.biokids.umich.edu/accounts/Podiceps\\_auritus/](http://www.biokids.umich.edu/accounts/Podiceps_auritus/)
- Harter, J.M. and Baker, D.H. 1978. *Factors Affecting Methionine Toxicity and Its Alleviation in the Chick*. J. Nutr. 108:1061.
- Health Canada. 2012a. *Part I: Guidance on Human Health Preliminary Quantitative Risk Assessment (PQRA), Version 2.0*. Federal Contaminated Site Risk Assessment in Canada. Contaminated Sites Division, Safe Environments Directorate. Prepared 2010, Revised 2012.



Health Canada. 2012b. *Part II: Health Canada Toxicological Reference Values (TRVs) and Chemical Specific Factors, Version 2.0*. Federal Contaminated Site Risk Assessment in Canada. Contaminated Sites Division, Safe Environments Directorate. Prepared 2010, Revised 2012.

Health Canada. 1994. *Guidelines for Canadian Drinking Water Quality - Technical Documents*. Sulphate. November 1987 (Updated September 1994). Available at <http://www.hc-sc.gc.ca/ewh-semt/pubs/water-eau/index-eng.php>

Health Canada. 1992a. *Guidelines for Canadian Drinking Water Quality - Technical Documents*. Sodium. May 1979 (Updated December 1992). Available at <http://www.hc-sc.gc.ca/ewh-semt/pubs/water-eau/index-eng.php>

Health Canada. 1992b. *Guidelines for Canadian Drinking Water Quality - Technical Documents*. Total Dissolved Solids. May 1979 (Updated December 1992). Available at <http://healthycanadians.gc.ca/publications/healthy-living-vie-saine/water-dissolved-solids-matieres-dissoutes-eau/index-eng.php>

Health Canada. 1987a. *Guidelines for Canadian Drinking Water Quality - Technical Documents*. Calcium. April 1979 (Updated November 1987). Available at <http://www.hc-sc.gc.ca/ewh-semt/pubs/water-eau/index-eng.php>

Health Canada. 1987b. *Guidelines for Canadian Drinking Water Quality - Technical Documents*. Chloride. September 1978 (Updated November 1987). Available at <http://www.hc-sc.gc.ca/ewh-semt/pubs/water-eau/index-eng.php>

Health Canada. 1987c. *Guidelines for Canadian Drinking Water Quality - Technical Documents*. Magnesium. September 1978 (Updated November 1987) Available at <http://www.hc-sc.gc.ca/ewh-semt/pubs/water-eau/index-eng.php>

Hickey, C.W. 1989. *Sensitivity of Four New Zealand Cladoceran Species and Daphnia magna to Aquatic Toxicants*. N.Z.J.Mar.Freshwater Res. 23(1):131-137.

International Atomic Energy Agency (IAEA). 2010. Handbook of Parameter Values for the Prediction of Radionuclide Transfer in Terrestrial and Freshwater Environments. Technical Reports Series No. 472.

- International Atomic Energy Agency (IAEA). 1992. *Effects of Ionizing Radiation on Plants and Animals at Levels Implied by Current Radiation Standards*, Technical Report Series No. 332.
- Institute of Medicine (IOM). 2004. *Dietary Reference Intakes for Water, Potassium, Sodium, Chloride and Sulfate*. National Academies.
- International Commission on Radiation Protection (ICRP). 1996. *Age-dependent Doses to Members of the Public from Intake of Radionuclides - Part 5 Compilation of Ingestion and Inhalation Coefficients*. ICRP Publication 72. Ann. ICRP 26 (1).
- Jenner, H.A. and J.P.M. Janssen-Mommen. 1993. *Duckweed Lemna Minor as a Tool for Testing Toxicity of Coal Residues and Polluted Sediments*. Arch.Environ.Contam.Toxicol. 25(1):3-11.
- Kadlec, M. 2003. *Dendroica petechia* (On-line), Animal Diversity Web. Accessed at [http://www.biokids.umich.edu/accounts/Dendroica\\_petechia/](http://www.biokids.umich.edu/accounts/Dendroica_petechia/)
- Krista, L.M.; Carlson, C.W. & Olson, O.E., 1961. *Some Effects of Saline Waters on Chicks, Laying Hens, Poults and Ducklings*. In: Poult. Sci. 40:938-944.
- Leach, R.M., Zeigler, T.R. and Norris, L.C. 1960. *The Effect of Dietary Dulphate in the Growth Rate of Chicks Fed a Purified Diet*. Poult. Sci. 39:1577.
- Liber K., S. deRosemond and K. Budnick. 2007. *Uranium Toxicity to Regionally-Representative Algae and Invertebrate Species*. Prepared for AREVA Resources Inc. and Cameco Corporation, October. Toxicology Centre, University of Saskatchewan.
- Loomis, J.S. 2013. *Effects of Simulated Angler Capture and Live-Release Tournaments on Walleye Survival*. Transactions of the American Fisheries Society, 142(3), 868-875. {cited in SENES 2014b}
- Low-Level Radioactive Waste Management Office (LLRWMO). 2005. *Terrestrial Environment Baseline Characterization Study: For the Port Hope Project*. Report No. LLRWMO-03780-ENA-12001 Revision 0. Prepared by AMEC Earth & Environmental. March.
- Mikita, K. 1999. *Sylvilagus floridanus* (On-line), Animal Diversity Web. Accessed at [http://animaldiversity.org/accounts/Sylvilagus\\_floridanus/](http://animaldiversity.org/accounts/Sylvilagus_floridanus/)

- National Council on Ionizing Radiation and Protection (NCRP). 1996. *Screening Models for Releases of Radionuclides to Atmosphere, Surface Water and Ground*. NCRP Report No. 123, Vol. I., NCRP, Bethesda, Maryland.
- National Institute of Public Health and the Environment (RIVM). 2001. *Re-Evaluation of Human-Toxicological Maximum Permissible Risk Levels*. March.
- National Research Council (NRC). 2005. *Mineral Tolerance of Animals*. Revised 2nd Edition. The National Academic Press. Washington, D.C.
- Natural Heritage Information Centre (NHIC). 2009. *NHIC Database*. Ontario Ministry of Natural Resources. November. Accessed February 2012 from: <http://nhic.mnr.gov.on.ca/MNR/nhic/data.cfm>.
- NatureServe. 2009. *International Ecological Classification Standard: Terrestrial Ecological Classifications*. NatureServe Central Databases. Arlington, VA. U.S.A.
- Ontario Ministry of the Environment (MOE). 2012a. *Ontario's Ambient Air Quality Criteria*. Standards Development Branch. April.
- Ontario Ministry of the Environment (MOE). 2012b. *Summary of Standards and Guidelines to Support Ontario Regulation 419/05 – Air Pollution Local Air Quality*. Standards Development Branch. April.
- Ontario Ministry of the Environment (MOE). 2011. *Rationale for the Development of Soil and Groundwater Standards for Use at Contaminated Sites in Ontario*. Standards Development Branch. PIBS 7386e01. 15 April.
- Ontario Ministry of the Environment (MOE). 2009. *Air Dispersion Modelling Guideline for Ontario*, Version 2.0. March.
- Ontario Ministry of the Environment (MOE). 2008a. *Guidelines for Identifying, Assessing and Managing Contaminated Sediments in Ontario: An Integrated Approach*. May.
- Ontario Ministry of the Environment (MOE). 2008b. *Jurisdictional Screening Level (JSL) List: A Screening Tool for Ontario Regulation 419: Air Pollution – Local Air Quality*. February.

- Ontario Ministry of the Environment (MOE). 2007. *Ontario Air Standards for Cadmium and Cadmium Compounds*. Standards Development Branch, June. Accessed December 9, 2014 at [http://www.downloads.ene.gov.on.ca/envision/env\\_reg/er/documents/2007/PA04E0015-f.pdf](http://www.downloads.ene.gov.on.ca/envision/env_reg/er/documents/2007/PA04E0015-f.pdf).
- Ontario Ministry of the Environment (MOE). 2005. *Procedures for the Use of Risk Assessment under Part XV.1 of the Environmental Protection Act*. Standards Development Branch. PIBS 5404e. October.
- Ontario Ministry of the Environment and Energy (MOEE). 1999. *Water Management Policies Guidelines: Provincial Water Quality Objectives of the Ministry of Environment and Energy*.
- Ontario Ministry of the Environment (MOEE). 1996. *Guidelines on Sampling and Analytical Methods for Use at Contaminated Sites in Ontario*. Standards Development Branch. ISBN-0-7778-4056-1. December.
- Ontario Ministry of Environment and Energy (MOEE). 1994. *Scientific Criteria Document for Multimedia Environmental Standards Development: Lead*. OMEE, Toronto.
- Popken, G.J. 1990. *Effects of Calcium on the Toxicity of Zinc to Embryos and Larvae of the Fathead Minnow (Pimephales promelas)*. M.S.Thesis, Eastern Kentucky University, Richmond, KY:64 p.
- Pröhl, G., ed. 2003. *Dosimetric Models and Data for Assessing Radiation Exposure to Biota*. Deliverable 3 Report of the FASSET project. European Commission, 103 pp. <http://wiki.ceh.ac.uk/display/rpemain/FASSET+reports>
- Puls, R. 1994. *Mineral Levels in Animal Health*. 2nd Edition. Shepra International. Clearbrook, B.C.
- Przytocka-Jusiak. 1976. *Growth and Survival of Chlorella Vulgaris in High Concentrations of Nitrogen*. Acta microbiol. Pol.
- RIVM (National Institute of Public Health and the Environment). 2001. *Re-Evaluation of Human-Toxicological Maximum Permissible Risk Levels*. RIVM report 711701 025, March.
- Rohner, C. 1997. *Non-territorial "floaters" in Great Horned Owls: Space use during a Cyclic Peak of Snowshoes Hares*. In: Animal Behaviour 53:901-912.
- Sample, B.E., J. J. Beauchamp, R.A. Efrogmson, and G.W. Suter II. 1998. *Development and Validation of Bioaccumulation Models for Small Mammals*. U.S. Department of Energy. February.

- Sample, B.E., D.M. Opresko, and G.W. Suter II. 1996. *Toxicological Benchmarks for Wildlife: 1996 Revision*. U.S. Department of Energy. June.
- Sasse, C.E. and D.H. and Baker. 1974. *Factors Affecting Sulfate Sulfur Utilization by the Young Chick*. Poul. Sci. 53:652.
- Scott, W.B. and E.J. Crossman. 1998. *Freshwater Fishes of Canada*. Galt House Publications Limited. Oakville, Canada. {cited in SENES 2014b}
- SENES Consultants (SENES). 2014a. *Baseline Entrainment Monitoring at Cameco Corporation Port Hope Conversion Facility, Spring-Summer 2014*. Prepared for Cameco Corporation, November.
- SENES Consultants (SENES). 2014b. *Port Hope Conversion Facility Thermal Risk Assessment Follow Up*. Prepared for Cameco Corporation, November.
- SENES Consultants (SENES). 2014c. *Acoustic Assessment Report for Cameco Port Hope Conversion Facility, Port Hope, Ontario*. Prepared for Cameco Corporation, May (revised October).
- SENES Consultants (SENES). 2013a. *Baseline Impingement and Entrainment Monitoring at Cameco Corporation Port Hope Conversion Facility Spring-Summer 2013*. Prepared for Cameco Corporation. November. {cited in SENES 2014a}
- SENES Consultants Limited (SENES). 2013b. *Baseline Impingement Monitoring at Cameco's Port Hope Conversion Facility Fall-Winter 2012*. Prepared for Cameco Corporation. February. {cited in SENES 2014a}
- SENES Consultants (SENES). 2013c. *Thermal Effects Risk Assessment for Port Hope Conversion Facility*. Prepared for Cameco Corporation, July.
- SENES Consultants (SENES). 2013d. *Risk Assessment Port Hope Conversion Facility Fence-Line Shift*. Prepared for Cameco Corporation, October.
- SENES Consultants Limited (SENES). 2012a. *Cameco Port Hope Conversion Facility Thermal Plume Effects Study*. Final report prepared for Cameco Corporation, March.

SENES Consultants Limited (SENES). 2012b. *Acoustic Assessment Report in Support of an Environmental Compliance Approval for Cameco Corporation Port Hope Conversion Facility, Port Hope, Ontario*. Prepared for Cameco Corporation, December.

SENES Consultants Limited (SENES). 2011a. *Port Hope Conversion Facility Soil Monitoring Program Review*. SENES Report #350370 prepared for Cameco Corporation, September.

SENES Consultants Limited (SENES). 2011b. *Description of Surrounding Environment Preliminary Decommissioning Cameco Port Hope Conversion Facility*, Issue 7, November 2010. SENES Letter 350261 prepared for Cameco Corporation. 5 August.

SENES Consultants Limited (SENES). 2010. *2010 Follow-up: Port Hope Conversion Facility Follow-Up Site-Wide Risk Assessment: Human Health and Ecological Risk Assessment*. SENES Report 34653-3, prepared for Cameco Corporation. December.

SENES Consultants Limited (SENES). 2009a. *Port Hope Conversion Facility Site-Wide Risk Assessment: Human Health and Ecological Risk Assessment*. SENES Report 34653, prepared for Cameco Corporation. June.

SENES Consultants Limited (SENES). 2009b. *Addendum to Port Hope Conversion Facility Site-Wide Risk Assessment: Human Health and Ecological Risk Assessment*. SENES Report 34653-2, prepared for Cameco Corporation. December.

SENES Consultants Limited (SENES). 2008. *Soil Characterization and Evaluation Study at Port Hope*. SENES Report #34406-5 prepared for Cameco Corporation, April.

SENES Consultants Limited (SENES). 2007. *Preliminary Human Health and Ecological Risk Assessment of Subsurface Contamination Associated with Process Liquid Leakage from Building 50, Port Hope Conversion Facility*. Prepared for Cameco Corporation. November.

SENES Consultants Limited (SENES). 2004. *Ecological Risk Assessment and Environmental Effects Monitoring for Cameco Facility – Port Hope*. Prepared for Cameco Corporation. June.

SENES Consultants Limited (SENES). 2003. *Phase I and Phase II Environmental Site Assessments – Port Hope Conversion Facility, Port Hope, Ontario*. Prepared for Cameco Corporation. April.

- SENES Consultants Limited and 4DM Inc. (SENES and 4DM). 2013. *Recommendations for Updating Guidelines for Mitigating the Impingement and Entrainment of Fish at Freshwater Intakes in Fisheries and Oceans Canada Central and Arctic Region*. {cited in SENES 2014a}
- SENES Consultants Limited and Seward Consultants Inc. (SENES and Seward). 2012. *Noise Abatement Action Plan Cameco Corporation Port Hope Conversion Facility*. Prepared for Cameco Corporation, December.
- Smith, L.R., T.M. Holsen, N.C. Ibay, R.M. Block, and A.B. De Leon. 1985. *Studies on the Acute Toxicity of Fluoride Ion to Stickleback, Fathead Minnow, and Rainbow Trout*. *Chemosphere* 14(9):1383-1389.
- SNC Lavalin (SLI). 2010a. *Cameco Vision 2010 Port Hope Conversion Facility Harbour Wall Area Investigation*. Report to Cameco Corporation. November.
- SNC Lavalin (SLI). 2010b. *Vision 2010: Port Hope Conversion Facility Comprehensive Environmental Site Investigations*. Prepared for Cameco Corporation.
- SNC Lavalin (SLI). 2007. *Supplementary Environmental Site Investigation, Port Hope Conversion Facility, Port Hope, Ontario*. Prepared for Cameco Corporation, February.
- SNC Lavalin (SLI). 2006. *Environmental Investigation, Parking Lot and Water Works, Cameco Vision 2010, Port Hope Conversion Facility*. Prepared for Cameco Corporation. December.
- Suter II, G.W. and C.L. Tsao. 1996. *Toxicological Benchmarks for Screening Potential Contaminants of Concern for Effects on Aquatic Biota: 1996 Revision*. Report ES/ER/TM-96/R2 prepared for the U.S. DOE Office of Environmental Management. June.
- Tetra Tech Canada Construction (Tetra Tech). 2013. *Supplemental Geotechnical / Geo-Environmental Field Investigation Report*. Port Hope Conversion Facility. Vision in Motion. Prepared for Cameco Corporation. February.
- Thompson, P.A., J. Kurias and S. Mihok. 2005. *Derivation and use of Sediment Quality Guidelines for Ecological Risk Assessment of Metals and Radionuclides Released to the Environment from Uranium Mining and Milling Activities in Canada*. In: *Environ Monit. Assess.* 110(1-3):71-85. November.

Total Petroleum Hydrocarbon Criteria Working Group (TPHCWG). 1997. *Total Petroleum Hydrocarbon Criteria Working Group Series – Volume 4: Development of Fraction Specific Reference Doses (RfDs) and Reference Concentrations (RfCs) for Total Petroleum Hydrocarbons (TPH)*. ISBN 1-884-940-13-7, Amherst Scientific Publishers.

U.K. EA. 2002. *Impact Assessment of Ionizing Radiation on Wildlife*. R&D Publication 128.

United Nations Scientific Committee on the Effects of Atomic Radiation (UNSCEAR). 1996. *UNSCEAR 1996 Report to the General Assembly, with scientific annex*.

United States Department of Energy (U.S. DOE). 2003. *Updated Aquatic Life Copper Criteria*. <http://www.epa.gov/waterscience/criteria/copper/2003/>

United States Department of Energy (U.S. DOE). 2002. *DOE Standard. A Graded Approach for Evaluating Radiation Doses to Aquatic and Terrestrial Biota*. July. DOE-STD-1153-2002.

United States Department of Energy Risk Assessment Information System (RAIS-HEAST). 2004. *Toxicity Summary for Boron*, available at website: [http://cfpub.epa.gov/ncea/iris/iris\\_documents/documents/subst/0410\\_summary.pdf](http://cfpub.epa.gov/ncea/iris/iris_documents/documents/subst/0410_summary.pdf)

United States Environmental Protection Agency (U.S. EPA). 2009. *National Recommended Water Quality Criteria*. Retrieved from: <http://water.epa.gov/scitech/swguidance/standards/criteria/current/index.cfm> August 2015.

United States Environmental Protection Agency (U.S. EPA). 2007a. *Ecological Soil Screening Levels for Copper*. Interim Final. OSWER Directive 9285.7-68. February.

United States Environmental Protection Agency (U.S. EPA). 2007b. *Ecological Soil Screening Levels for Manganese*. Interim Final. OSWER Directive 9285.7-71. April.

United States Environmental Protection Agency (U.S. EPA). 2007c. *Ecological Soil Screening Levels for Nickel*. Interim Final. OSWER Directive 9285.7-76. March.

United States Environmental Protection Agency (U.S. EPA). 2007d. *Ecological Soil Screening Levels for Selenium*. Interim Final. OSWER Directive 9285.7-72. July.



United States Environmental Protection Agency (U.S. EPA). 2007e. *Ecological Soil Screening Levels for Zinc*. Interim Final. OSWER Directive 9285.7-73. June.

United States Environmental Protection Agency (U.S. EPA). 2006. *Provisional Peer-Reviewed Toxicity Values for Aluminum*.

United States Environmental Protection Agency (U.S. EPA). 2005a. *Ecological Soil Screening Levels for Arsenic*. Interim Final. OSWER Directive 9285.7-62. March.

United States Environmental Protection Agency (U.S. EPA). 2005b. *Ecological Soil Screening Levels for Cadmium*. Interim Final. OSWER Directive 9285.7-65. March.

United States Environmental Protection Agency (U.S. EPA). 2005c. *Ecological Soil Screening Levels for Cobalt*. Interim Final. OSWER Directive 9285.7-67. March.

United States Environmental Protection Agency (U.S. EPA). 2005d. *Ecological Soil Screening Levels for Lead*. Interim Final. OSWER Directive 9285.7-70. March.

United States Environmental Protection Agency (U.S. EPA). 2004. Risk Assessment Guidance for Superfund Volume I: Human Health Evaluation Manual (Part E, Supplemental Guidance for Dermal Risk Assessment). Final. July. EPA/540/R/99/005.

United States Environmental Protection Agency (U.S. EPA). 2003. *Title 40 – Protection of Environment*. Code of Federal Regulations, Appendix W to Part 51 – Guideline on Air Quality Models; 40 CFR Ch. I (7-1-03 Edition). [http://www.epa.gov/scram001/guidance/guide/appw\\_03.pdf](http://www.epa.gov/scram001/guidance/guide/appw_03.pdf).

United States Environmental Protection Agency (U.S. EPA). 1999a. *Screening Level Ecological Risk Assessment (SLERA) Protocol for Hazardous Waste Combustion Facilities*.

U.S. EPA (U.S. Environmental Protection Agency). 1999b. *1999 Update of Ambient Water Quality Criteria for Ammonia*. Office of Water. EPA-822-R-99-014. Washington, D.C.

United States Environmental Protection Agency (U.S. EPA). 1993. *Wildlife Exposure Factors Handbook: Volume I*. U.S. EPA Report U.S. EPA/600/R-93/187. Washington, D.C., USA. United States Environmental Protection Agency (U.S. EPA). 1989. *Risk Assessment Guidance for Superfund. Human Health Evaluation Manual: Part A. Interim Final*. Washington, DC: Office of Solid Waste and Emergency Response. <http://www.epa.gov/superfund/programs/risk/ragsa/index.htm>. Available from NTIS, Springfield, VA; PB-90-155581.

United States Environmental Protection Agency (U.S. EPA). *Ecological Soil Screening Levels (Eco-SSLs)*. Accessed from: <http://www.epa.gov/risk/ecological-soil-screening-level-eco-ssl-guidance-and-documents>.

United States Environmental Protection Agency (U.S. EPA) *IRIS United States Environmental Protection Agency Integrated Risk Information System On-Line A-Z List of Substances*, Accessed from <http://cfpub.epa.gov/ncea/iris/index.cfm?fuseaction=iris.showSubstanceList>.

United States National Council on Radiation Protection and Measurements (U.S. NCRP). 1991. *Effects of Ionizing Radiation on Aquatic Organisms*. NCRP NO. 109.

University of Michigan. *Animal Diversity Web*.

VST (Vizon SciTec Inc.), 2004. *Final Report on the Toxicity Investigation of Uranium to Aquatic Organisms*. Prepared for the Canadian Nuclear Safety Commission, April.

Wallen, I.E., W.C. Greer, and R. Lasater. 1957. *Toxicity to Gambusia affinis of Certain Pure Chemicals in Turbid Waters*. Sewage Ind. Wastes 29(6):695-711

Wang, W. 1994. *Rice Seed Toxicity Tests for Organic and Inorganic Substances*. Environ. Monit. Assess. 29:101-107.

Water Pollution Research Board (WPRB). 1960. *Toxicity of Un-Ionized Ammonia In: Water Pollution Research 1959*, Water Pollution Research Board, Dep. of Scientific and Industrial Research, H.M. Stationery Office, London, England:74-80.

White, A. 1986. *The Condition of Fishes Impinged at the Ohio Edison Edgewater Generating Facility April 15, 1985 – October 15, 1985*. Report prepared for Ohio Edison Company, Akron, Ohio. {cited in SENES 2014a}.

World Health Organization (WHO). 2010. *Strontium and Strontium Compounds*. Concise International Chemical Assessment Document 77.

World Health Organization (WHO). 2009. *Bromide in Drinking-water*. Background document for development of WHO Guidelines for Drinking-water Quality. WHO/HSE/WSH/09.01/6.

World Health Organization (WHO). 1996. *Water Quality Assessment – A Guide to Use of Biota, Sediments and Water in Environmental Monitoring – Second Edition*. Available at: [http://www.who.int/water\\_sanitation\\_health/resourcesquality/wqa/en/index.html](http://www.who.int/water_sanitation_health/resourcesquality/wqa/en/index.html).

**Arcadis Canada Inc.**

121 Granton Drive, Suite 12  
Richmond Hill, ON L4B 3N4  
Tel 905.764.9389  
Fax 905.764.9386

**[Arcadis.com](http://Arcadis.com)**